

PCM MOINEAU™ A

API COMPLIANT
PROGRESSING CAVITY PUMP

www.pcm.eu

“THE PERFECT COMBINATION OF API STANDARDS AND PCM EXPERTISE”

The PCM Moineau™ A series pump is a culmination of our unrivalled industry expertise and our unwavering commitment to provide the best fluid handling solutions.

PCM has been serving the Oil & Gas industry for over 40 years, and we brought **the first Progressing Cavity Pump to the world in 1932**. Named after its inventor, the Moineau™ pump became widely used as a surface pump, especially for **the pumping of viscous mixtures in many applications** where traditional pumps are too inefficient.

▶ THE PCM MOINEAU™ A SERIES PUMP COMPLIES WITH API 676

The American Petroleum Institute leads the development of standards for materials & equipment for use in the Oil & Gas industry. Its standards have been adopted worldwide for decades with the aims of enhancing technical integrity, improving safety, reducing environmental impact and business efficiencies resulting in reduced costs for end users.

API standard 676 provides the minimum standards for rotary positive displacement pumps for use in Oil & Gas applications, and whose function is **key to successful operations**.



▶ OPERATING PRINCIPLE

A Moineau™ pump consists of a helical rotor turning inside a helical stator. The metallic rotor is machined to a high degree of precision, and the stator is moulded in a resilient elastomer.

The geometry and the dimensions of these parts are such that when the rotor is inserted into the stator, a double chain of watertight cavities is created. When the rotor turns inside the stator, the cavity progresses spirally along the axis of the pump without changing either shape or volume.

▶ PCM MOINEAU™ TECHNOLOGY

The PCM Moineau™ progressing cavity pump technology brings multiple benefits :

- Gently conveys fluids, with low shearing effect
- Transfers viscous fluids
- Lowest NPSH of all positive displacement pumps
- Performs across a range of viscosities
- Handles fluids with suspended solids such as sand
- Handles fluids with free gas
- Easy to maintain
- Reversible
- Flow rate proportional to running speed

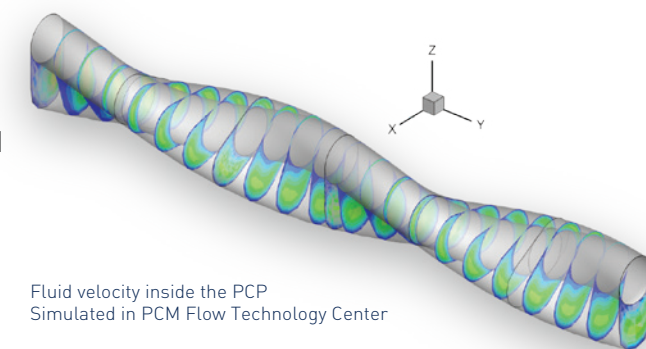

PCM MOINEAU™ A HIGHLIGHTS & PERFORMANCES

PCM's API 676 pump features a highly modular design that makes installation, operation and service easier in many applications.

Maximum flowrate	70 m ³ /hr / 310 US gpm
Maximum differential pressure	24 bar / 350 psi
Maximum fluid temperature*	130 °C / 265 °F
Minimum fluid temperature*	-12 °C / 10 °F
Maximum fluid viscosity*	10 000 cP
Ambient temperature range	-40 °C to +55 °C / -40 °F to +130 °F

For applications exceeding above limits, a variety of pump designs are available at PCM. Please contact our PCM representative.

*During pump operation



ACCESSORIES

A range of accessories are available to ensure safe and reliable operations :

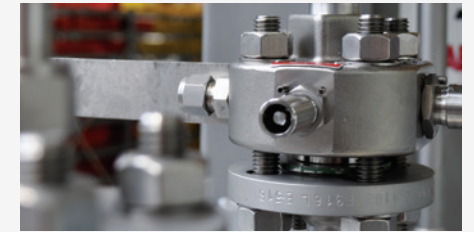

- Dry running protection
- Overpressure protection & monitoring:
 - Pressure relief valves to API 520/526/527
 - Pressure transmitters; overpressure protection with options for hazardous areas
- Variable speed drives
- Stator cladding for low ambient temperature applications.

We have the following standard options for API seal plans :

- API plan 13 (standard for vertical pumps)
- API plan 02/61 (standard for horizontal pumps)
- API plan 65
- API plan 53A
- API plan 53B



CONSTRUCTION

Articulated drive shaft: shorter and lighter

The PCM Moineau™ A pump incorporates a high strength articulated drive shaft to accommodate the eccentric motion of the rotor, and features a patented connecting system for **quick and easy dismantling** during maintenance.



The articulated design ensures a **compact casing**, using less raw material, a reduced overall footprint and minimal clearance for maintenance operations.

The shaft design allows for a smaller diameter mechanical seal without compromising performance. This leads to reductions in capital and operating costs.

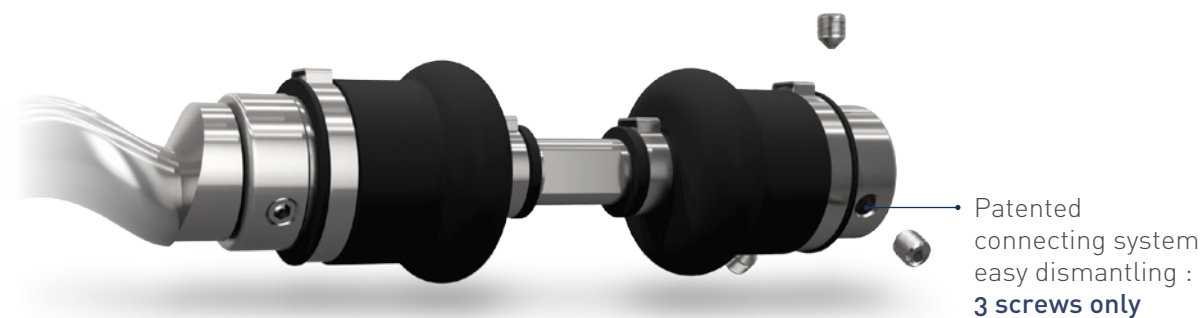

VERTICAL INSTALLATIONS

When circumstances allow, vertical installations are a great way to **simplify the installation** and reduce equipment footprint. The PCM Moineau™ A range includes vertical pump options that can be **mounted directly to a storage tank**, drum, caisson or pit.

Pump lengths can be customised, with casing and drive shaft extensions to suit.

CONFIGURATIONS

The PCM Moineau™ A pump is available in two configurations, each featuring API mechanical sealing options :

Monobloc

Simplest design with shortest footprint.

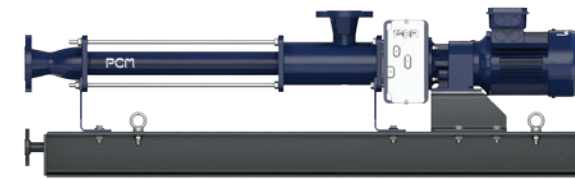

Bearing

Long coupled; the most robust design for high torque applications. Allows multiple drive options (e.g. diesel, hydraulic...)

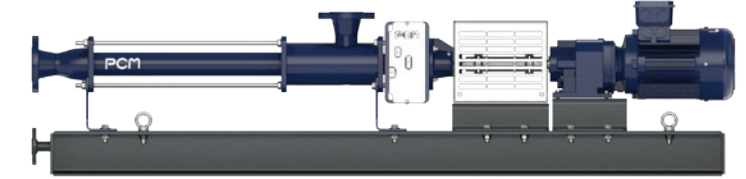

FEATURES

PCM Moineau™ A pumps features the following standard options for oil & gas applications :

- Multi-coat Epoxy paint system for harsh and corrosive environments (ISO12944, C3 or C5M environments).
- API 682 cartridge mechanical seals for high performance, reliability and reduced maintenance costs.
- Bi-directional operation; discharge or suction at seal side options.
- Optional API671 corrosion resistant metallic flexible coupling and spacer.
- Drive shaft designs for low and high torque applications and a range of operating pressures.

QUALITY RECORDS

- Material certification to EN10204 3.1 for pressure wetted metallic parts.
- Optional materials and certification to NACE MR0175/ MR0103 for H₂S containing applications.
- API inspection & testing options; performance, hydrostatic, NPSH, noise and vibration.
- API documentation options.

MATERIALS

Multiple material options offer optimised designs for a wide variety of applications :

- Pump casings in carbon steel, AISI 316 stainless steel, 22Cr duplex and 25Cr duplex stainless steels.
- Process wetted rotating parts in Halar® (ECTFE) coated AISI 4340 nitrited steel and 22Cr duplex stainless steel.
- Process wetted seals in AISI 316 stainless steel, 22Cr duplex and 25Cr duplex stainless steels.
- Hard wearing chromium plated rotors for low friction and abrasion resistance.
- Fluorocarbon (FKM) or Nitrile (NBR) elastomer stators, formulated by PCM elastomer experts and manufactured in house.

▶ APPLICATIONS

Oil & Gas processing

- Open & closed drains transfer
- Flare KO drum emptying
- Crude oil transfer
- Hydrocarbon condensate transfer
- Rich MEG / Glycol
- Hydrocarbon sludge

Enhanced oil recovery

- EOR polymer transfer
- Surfactant transfer

Produced water management

- Produced water transfer
- Skimmed oil transfer

Well services

- Well Testing > Crude Oil Transfer
- Drilling mud > Decanter centrifuge feeding

Refinery

- Sludge transfer
- Oily water treatment
- Catalyst slurry

Storage & Distribution

- Crude oil transfer
- Tank stripping
- Oily sludge

