



Компания ПромХимТех-
официальный дистрибьютор
насосов Flowserve
www.promhimtech.ru
Тел. 8 800 250-01-54
e-mail: zakaz@promhimtech.ru

Chemical Processing

Process • Heat Transfer • Effluent Treatment • Auxiliary



Experience In Motion



Pump Supplier to the World

Flowserve is the driving force in the global industrial pump marketplace. No other pump company in the world has the depth or breadth of expertise in the successful application of pre-engineered, engineered, and special purpose pumps and systems.

Standing Alone as the Leader in the Chemical Processing Industry

Since introducing the world's first chemical processing pump more than three quarters of a century ago, Flowserve has pioneered the industry's most important milestones, including:

- The design of the first back pull-out pump, which was the forerunner of the ANSI standard
- The development of Alloy 20
- The development of SealSentry seal chambers for optimizing seal life

Engineering design, material expertise and application know-how are core strengths of Flowserve. No other pump company offers its array of ASME (ANSI) and ISO chemical process pumps.



Product Brands of Distinction

ACEC™ Centrifugal Pumps

Aldrich™ Pumps

Byron Jackson® Pumps

Calder™ Energy Recovery Devices

Cameron™ Pumps

Durco® Process Pumps

Flowserve® Pumps

IDP® Pumps

INNOMAG® Sealless Pumps

Lawrence Pumps®

Niigata Worthington™ Pumps

Pacific® Pumps

Pleuger® Pumps

Scienco™ Pumps

Sier-Bath® Rotary Pumps

TKL™ Pumps

United Centrifugal® Pumps

Western Land Roller™ Irrigation Pumps

Wilson-Snyder® Pumps

Worthington® Pumps

Worthington Simpson™ Pumps



Pump Designs

Flowserve offers a wide range of complementary pump types, built to recognized global standards and customer specification. These include:

- Single-stage process
- Between bearings single-stage
- Between bearings multistage
- Vertical
- Submersible motor
- Positive displacement
- Nuclear
- Specialty

Available Configurations

- Sealed and sealless
- Axially and radially split
- Volute and diffuser
- Close coupled and long coupled
- Single and double casing



Committed to the Complete Pump System Life Cycle

For more than two centuries, Flowserve has served industries requiring solutions that add value and reduce costs throughout the life cycle of a pumping system.

- Chemical
- Oil and gas
- Power generation
- Water
- General industry

Flowserve partners with customers to respond to the dynamic business conditions that affect them. Flowserve works with customers to improve efficiency, maximize throughput and control process quality. Whether customer needs involve on-site technical assistance, equipment upgrades or broader project planning with full turnkey responsibility, Flowserve delivers professional, reliable results.





The Chemical Industry-Flowserve Interface

While facing many of the same business challenges as other global industries, the chemical industry remains centrally focused on the creation of new processes that enhance productivity, increase energy efficiency, improve safety and protect the environment. Whether through traditional synthesis and catalysis or through

developing techniques, such as bioprocessing, cryogenic processing, and new reactor and separation technologies, Flowserve can fully meet the liquid movement, sealing and control needs of the chemical industry.



Materials Expertise

Flowserve offers its customers an extensive range of corrosion-resistant materials — both metallic and non-metallic — along with the materials application expertise to provide the safest, most cost-effective solutions for the very difficult services found in chemical processing.

In the forefront of materials engineering with the development of Alloy 20 (CN7M), DC8 and Durcomet 100 (CD4MCu) to its credit, Flowserve also designed the industry's first epoxy pump and fully PTFE-lined pump. For assured quality, Flowserve sources stainless steel, nickel alloys, light reactive alloys and engineered polymers from the world's foremost foundries and manufacturing facilities.

Engineering Design

Flowserve chemical process pumps are renowned for their reliability with minimal total life cycle cost. They are versatile and adaptable to virtually any chemical service due to the extraordinary combination of materials and pump configurations available. Having pioneered the concepts of the reverse vane impeller, back pull-out design, parts interchangeability and external shaft adjustment, Flowserve has earned an unequaled reputation for innovative pump technology.

Application Know-How

Flowserve sales engineers are highly regarded for their knowledge and skill in helping customers solve difficult process problems. Supporting their efforts is a staff of professionally qualified materials, product and applications engineers who can provide more detailed technical assistance when needed. They can also assist the customer with maintenance advice as well as spare parts recommendations and inventory analysis.

Uniquely Positioned

Key to the design and selection of pumps and systems for the chemical industry is the ability to withstand high temperatures, high pressures, highly corrosive liquids, abrasive slurries and toxic fluids. As new processes develop, the trends in these factors are for increased rather than less severity.

With more than 90 years of service to the chemical industry, Flowserve is uniquely positioned to address and meet these challenges with the broadest and deepest product lines available.



Chemical Service

Flowserve is the leading supplier of chemical process pumps worldwide. Its broad pump lines conform to ASME (ANSI) and ISO dimensional and design criteria and are available in a wide variety of configurations. A broad range of metallic and non-metallic materials addresses the diverse requirements of the chemical industry, including severe corrosion and erosion resistance and product purity concerns.

Along with premier products, Flowserve offers full service capabilities, from start-up and commissioning to routine and repair maintenance to spare parts inventory and asset management programs.





Versatility, Durability, Reliability

Regardless of the process — traditional synthesis and catalysis or new developmental technologies ... regardless of output — bulk chemicals and petrochemicals or fine chemicals and pharmaceuticals ... Flowserve offers the pumps and systems needed by the chemical industry to effectively move:

- Process liquids, including low-flow/high-head, toxic and temperature-sensitive applications
- Heat transfer fluids for chillers and condensers to cooling towers, heat exchangers and heat recovery steam generators
- Transportation, including transfer, storage, tank car loading/unloading and pipeline
- Effluent treatment



Global Alliances, Support and Service

A measure of Flowserve leadership in the chemical processing industry is its alliances with the world's most prominent chemical companies. While these relationships are typically global, they also include localized partnerships and service agreements.



Plant-Wide Service

Flowserve is among the world's largest and most diverse industrial pump manufacturers. In addition to its capabilities in chemical processing, Flowserve is a leading supplier to the petroleum, power generation and water resources industries. This strength permits Flowserve to satisfy virtually all its customers' plant-wide pumping needs, from plant water to the power house to auxiliary services. When required, Flowserve can also provide a full complement of ISO 13709/API 610 hydrocarbon process pumps in all configurations.

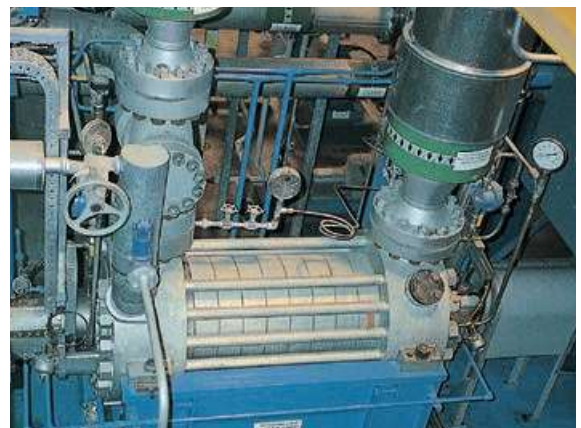

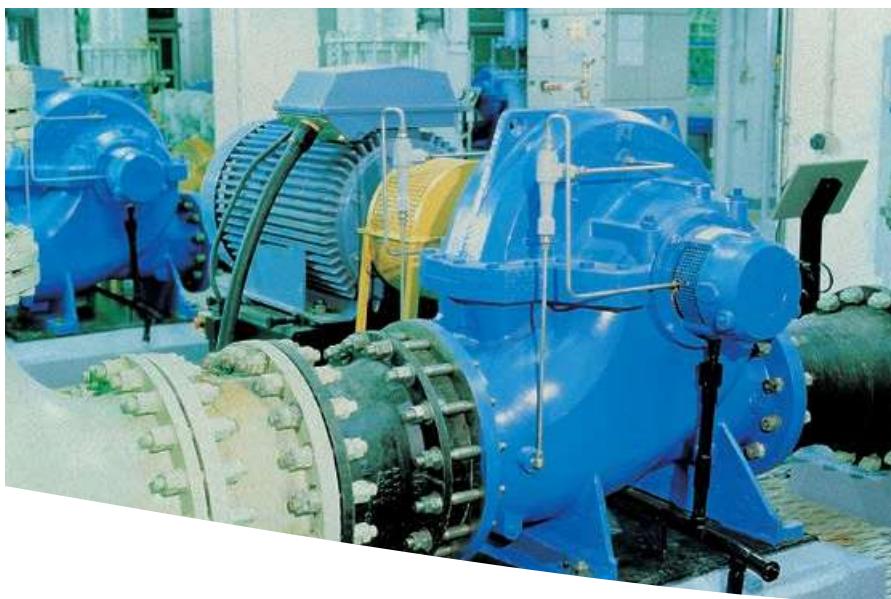

Power Generation

The comprehensive lines of Flowserve pump products and pumping systems are ideally suited for fossil fuel power generation and combined cycle power generation, including co-generation of electrical power and steam. Services include:

- Boiler feed water
- Circulating water
- Condensate cooling water
- Flue gas desulphurization

Water

Flowserve offers a complete line of vertical and horizontal type pumps to handle a wide range of flows and pressures for:

- Intake
- Borehole (well)
- Treatment
- Cooling tower

Auxiliary

These services include:

- System protection
- Sump drain off
- Safety systems
- High-pressure wash-down
- General service

Leading the Pump Industry

As the global leader in pump design and engineering for the chemical processing industry, Flowserve plays a major role in the practical implementation of new and improved process technologies. Flowserve accomplishes this through a continuous commitment to research and technology and by its leadership in these important industry organizations and committees:

- API
- ASME
- ASTM
- Europump
- HI
- ISO
- NACE
- NFPA

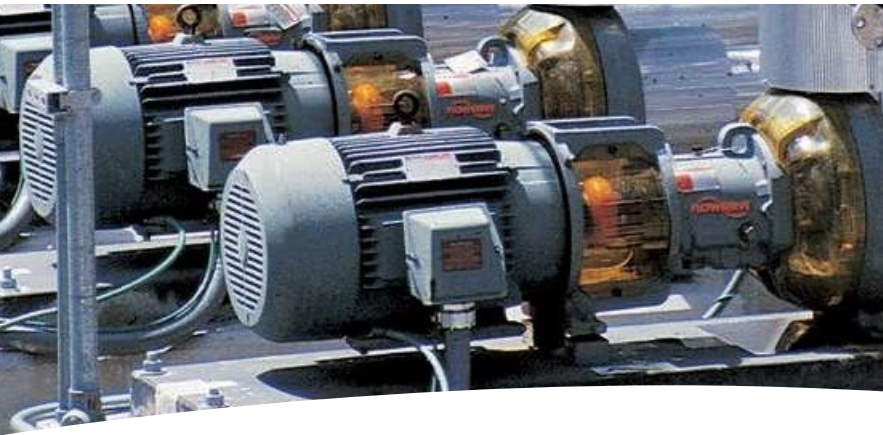

Chemical Process Pumps

ASME (ANSI) and ISO Standard Pumps

Flowserve sells and services a complete line of single-stage, overhung ASME B73 and ISO 2858-5199 chemical process pumps. The offering includes shaft sealed and sealless magnetically driven pumps, long and close coupled models, and both metallic and non-metallic materials options. Pump types include:

- Standard
- Low-flow
- Dynamically sealed
- Unitized self-priming
- Recessed impeller
- In-line
- Vertical sump
- Magnetic drive

Durco Mark 3™ ASME Standard

Operating Parameters

- Flows to 4540 m³/h (20 000 gpm)
- Heads to 215 m (700 ft)
- Pressures to 27 bar (400 psi)
- Temperatures to 370°C (700°F)

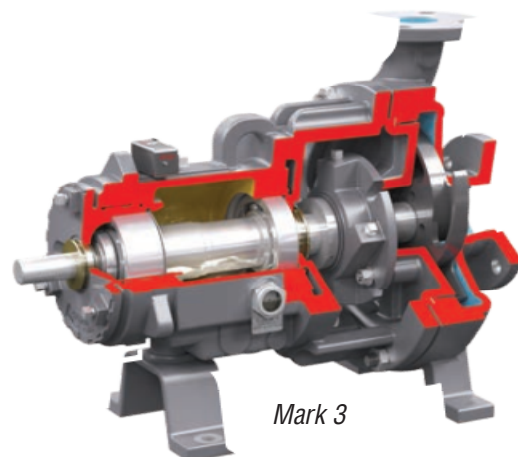

Mark 3

Durco Mark 3 ISO Standard

Operating Parameters

- Flows to 1400 m³/h (6160 gpm)
- Heads to 220 m (720 ft)
- Pressures to 25 bar (365 psi)
- Temperatures to 400°C (752°F)

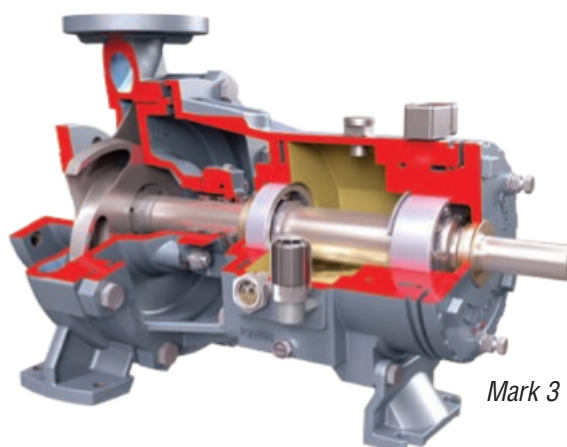

Mark 3 ISO



CPXSM and Guardian® Magnetically Driven, Close Coupled and Long Coupled

Operating Parameters

- Flows to 420 m³/h (1850 gpm)
- Heads to 215 m (700 ft)
- Pressures to 25 bar (365 psi)
- High temperatures design to 290°C (550°F)

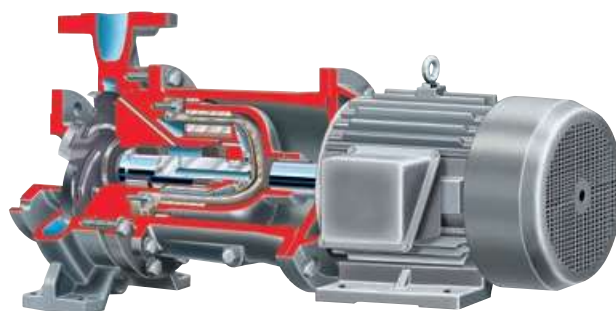

CPXSM

Mark 3 ISO Self-Priming and Mark 3 Unitized Self-Priming

Operating Parameters

- Flows to 320 m³/h (1400 gpm)
- Heads to 120 m (400 ft)
- Pressures to 25 bar (365 psi)

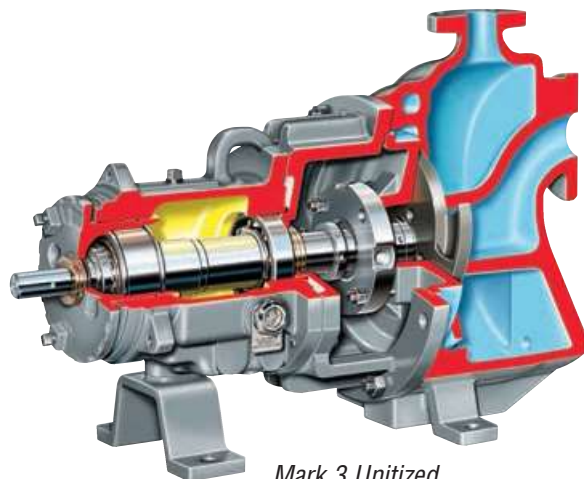

Mark 3 Unitized Self-Priming Pump

Mark 3 Lo-Flo™

Operating Parameters

- Flows to 50 m³/h (220 gpm)
- Heads to 300 m (985 ft)
- Pressures to 31 bar (450 psi)

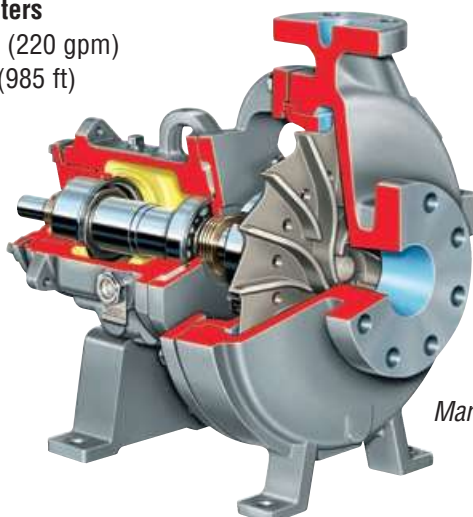

Mark 3 Lo-Flo

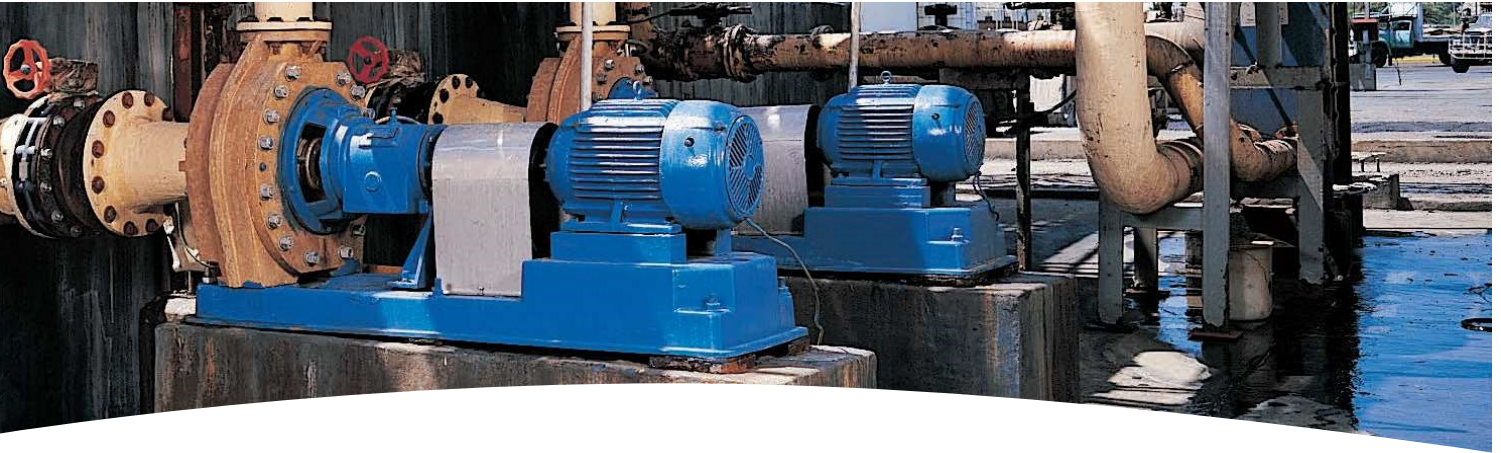

Chemical Process Pumps

PolyChem™ Non-metallic Pumps

Engineered to ASME and ISO design criteria and JIS drilling specifications

S-Series PFA-Lined

Operating Parameters

- Flows to 420 m³/h (1850 gpm)
- Heads to 145 m (480 ft)
- Pressures to 17 bar (250 psi)
- Temperatures to 150°C (300°F)

PolyChem GRP Engineered Composite

Operating Parameters

- Flows to 2050 m³/h (9000 gpm)
- Heads to 150 m (500 ft)
- Pressures to 17 bar (250 psi)
- Temperatures from -45°C (-50°F) to 120°C (250°F)

INNOMAG Fluoropolymer-Lined, Magnetic Drive Pump

Sealless ETFE lined pumps

TB-MAG™ Thrust-Balanced Magnetic Drive Pump

ASME B73.3 or ISO 2858 dimensional standards

Operating Parameters

- Flows to 340 m³/h (1500 gpm)
- Heads to 153 m (500 ft)
- Pressures to 21 bar (300 psi)
- Temperatures from -29°C to 120°C (-20°F to 250°F)

U-MAG™ Magnetic Drive Pump

Operating Parameters

- Flows to 102 m³/h (450 gpm)
- Heads to 50 m (165 ft)
- Pressures to 17 bar (250 psi)
- Temperatures from -29°C to 121°C (-20°F to 250°F)

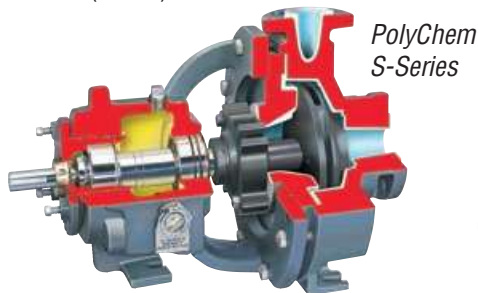

PolyChem S-Series

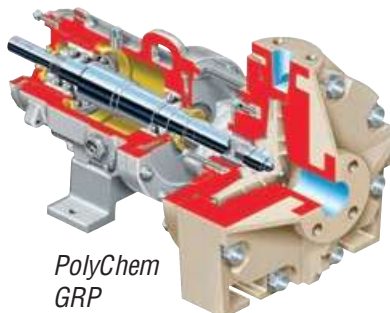

PolyChem GRP



U-MAG

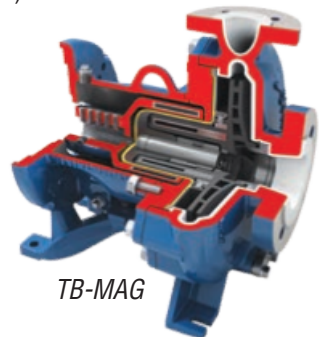

TB-MAG



***Gearex® Positive Displacement
Timed Gear***

Operating Parameters

- Flows to 180 m³/h (800 gpm)
- Pressures to 20 bar (300 psi)
- Temperatures to 450°C (842°F)
- Viscosities to 20 000 cP

***PolyChem VGRP and
ESP3 Vertical Sump***

Operating Parameters

- Flows to 1300 m³/h (5700 gpm)
- Heads to 110 m (350 ft)
- Pressures to 17 bar (250 psi)
- Temperatures to 180°C (350°F)

TSP Double-Suction, Twin Screw

Operating Parameters

- Flows to 2550 m³/h (11 200 gpm)
- Pressures to 100 bar (1450 psi)
- Temperatures to 450°C (842°F)
- Viscosities to 55 million cP

*PolyChem
VGRP*

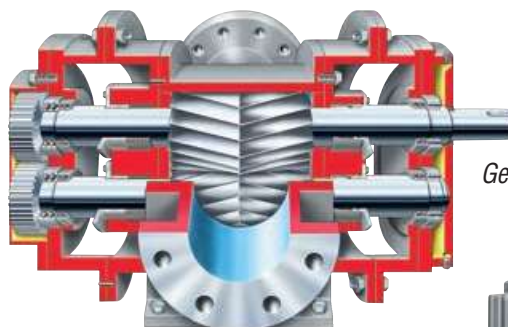

Gearex

Mark 3 In-Line

Operating Parameters

- Flows to 370 m³/h (1630 gpm)
- Heads to 230 m (755 ft)
- Pressures to 24 bar (350 psi)
- Temperatures to 370°C (700°F)

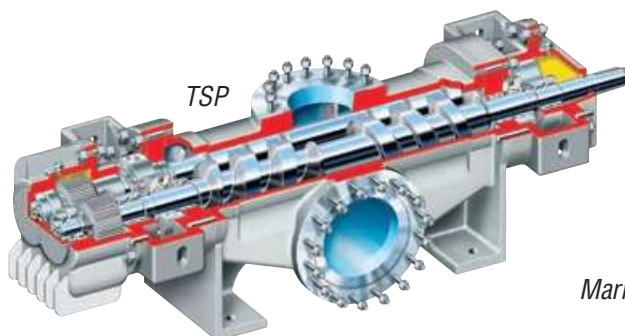

TSP

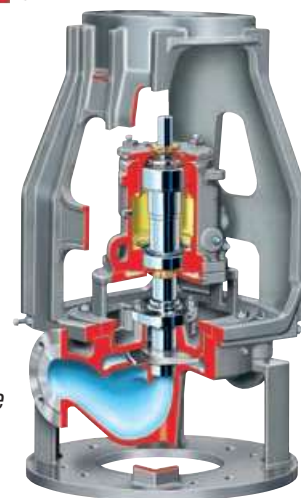

Mark 3 In-Line



Heat Transfer Fluids Pumps

Guardian Magnetically Driven

Operating Parameters

- Flows to 375 m³/h (1650 gpm)
- Heads to 215 m (700 ft)
- Pressures to 24 bar (350 psi)
- Temperatures to 290°C (550°F)

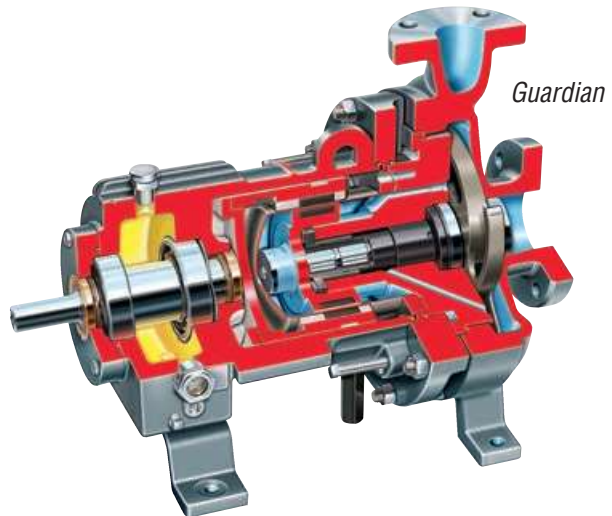

ISO 13709/API 610 Vertical In-Line

Operating Parameters

- Flows to 3400 m³/h (15 000 gpm)
- Heads to 900 m (2955 ft)
- Pressures to 60 bar (870 psi)
- Temperatures to 350°C (660°F)

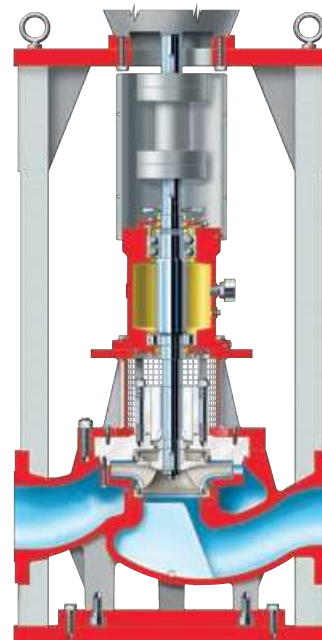

Centerline Mounted Process

Operating Parameters

- Flows to 2000 m³/h (8800 gpm)
- Heads to 400 m (1300 ft)
- Pressures to 80 bar (1160 psi)
- Temperatures to 450°C (842°F)

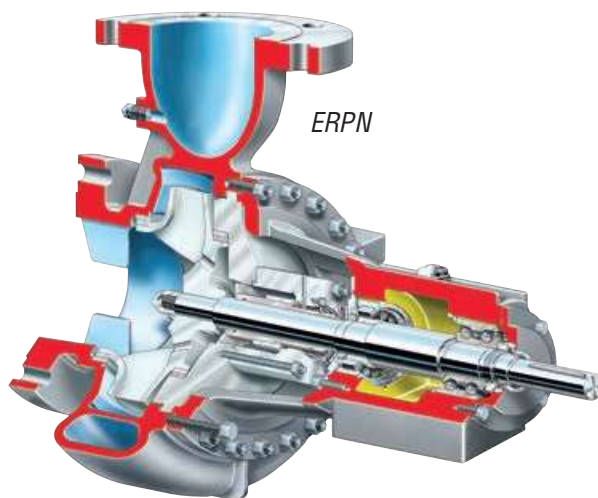

PVXM



Effluent Treatment Pumps

Mark 3 Recessed Impeller

Operating Parameters

- Flows to 455 m³/h (2000 gpm)
- Heads to 120 m (400 ft)
- Pressures to 20 bar (285 psi)
- Temperatures to 370°C (700°F)

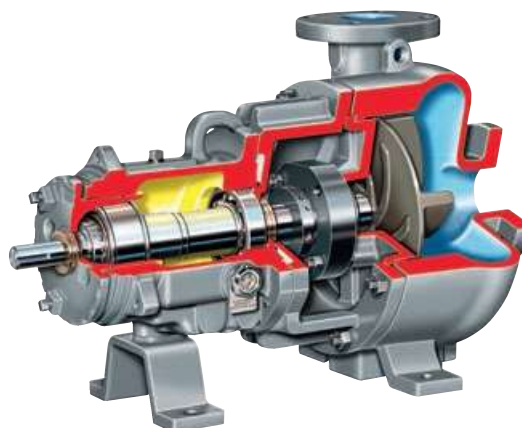

Mark 3
Recessed Impeller

Slurry-Abrasive, Hard Metal and Rubber-Lined

Operating Parameters

- Flows to 10 000 m³/h (44 000 gpm)
- Heads to 90 m (300 ft)
- Pressures to 50 bar (725 psi)
- Temperatures to 120°C (250°F)
- Solids from 2% to 70% by weight
Note: Hardened metal and high chrome iron material options

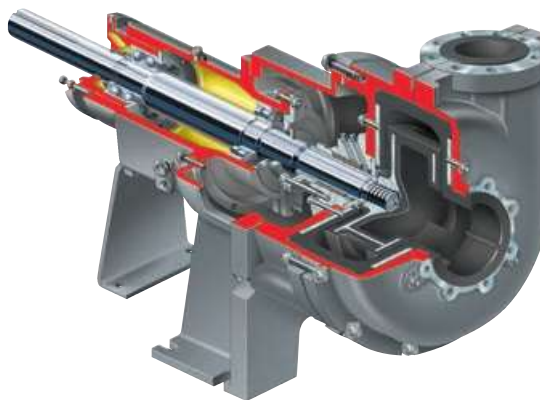

Type R

Submersible Solids Handling

Operating Parameters

- Flows to 4545 m³/h (20 000 gpm)
- Heads to 90 m (300 ft)
- Temperatures to 40°C (104°F)
- Solids to 80 mm (3 in) spherical

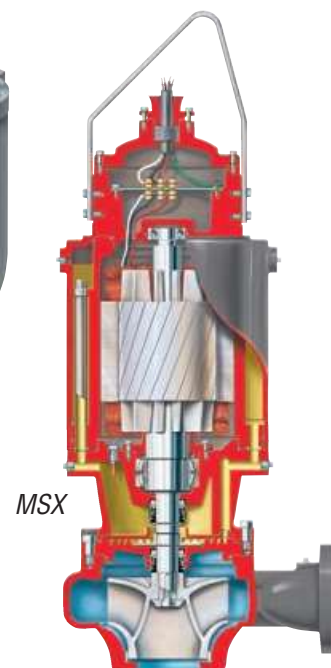

MSX



Water and Auxiliary Services Pumps

Single-Stage, Overhung, General and Slurry Service

Operating Parameters

- Flows to 9085 m³/h (40 000 gpm)
- Heads to 100 m (330 ft)
- Pressures to 14 bar (200 psi)
- Temperatures to 150°C (300°F)

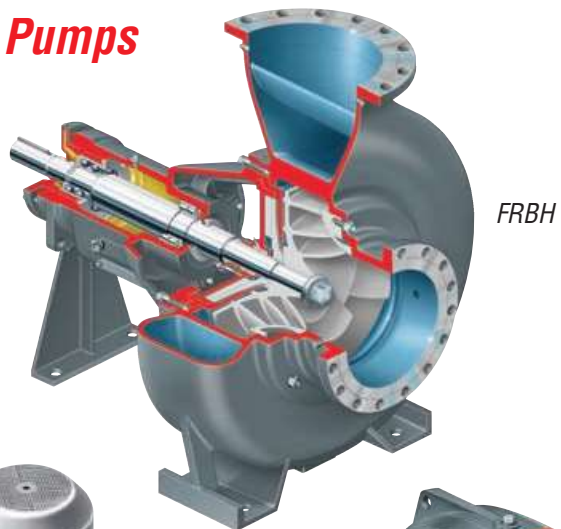

CPXV Vertical Sump

Operating Parameters

- Flows to 1400 m³/h (6160 gpm)
- Heads to 250 m (820 ft)
- Pressures to 25 bar (365 psi)
- Temperatures to 400°C (752°F)

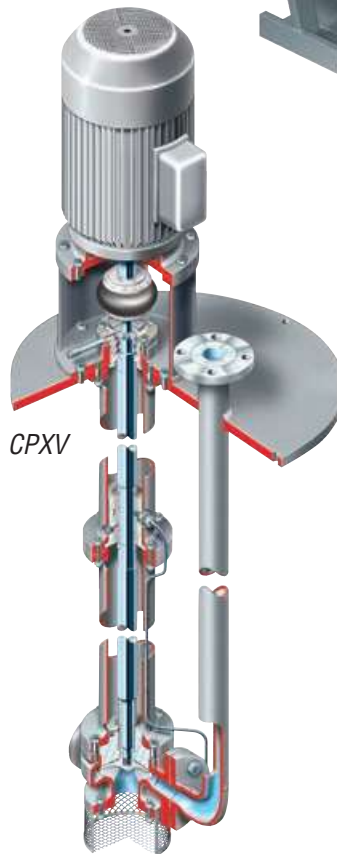

Axially Split, Double-Suction, Single-Stage

Operating Parameters

- Flows to 30 000 m³/h (132 000 gpm)
- Heads to 300 m (985 ft)
- Pressures to 40 bar (580 psi)
- Temperatures to 140°C (285°F)

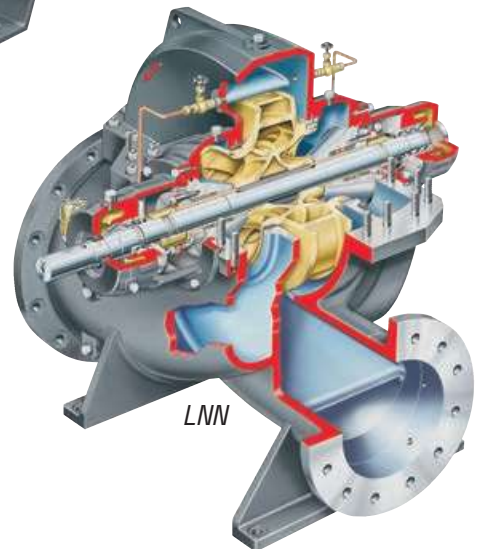

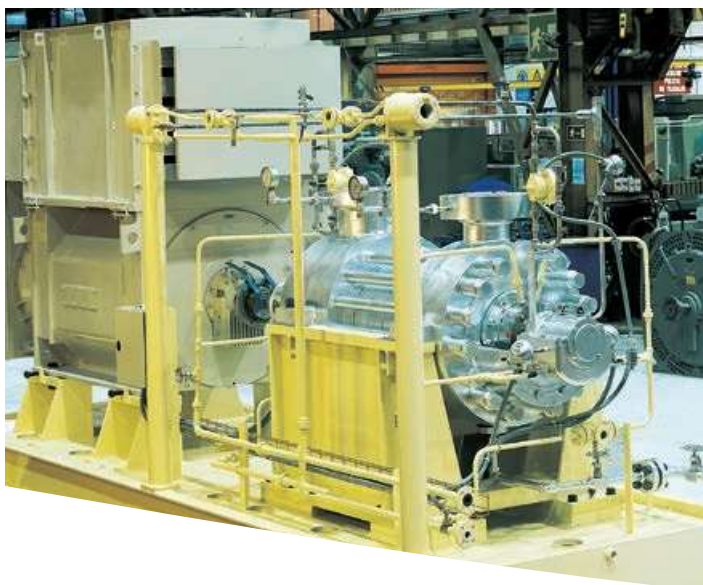

Power Generation Pumps

Vertical, Single- and Multistage, Wet-Pit

Operating Parameters

- Flows to 13 600 m³/h (60 000 gpm)
- Heads to 700 m (2300 ft)
- Pressures to 100 bar (1450 psi)
- Temperatures to 300°C (570°F)
- Sizes from 150 mm (6 in) to 1375 mm (54 in)

Multistage, Segmental Ring

Operating Parameters

- Flows to 900 m³/h (4000 gpm)
- Heads to 2650 m (8700 ft)
- Pressures to 310 bar (4500 psi)
- Temperatures to 250°C (480°F)

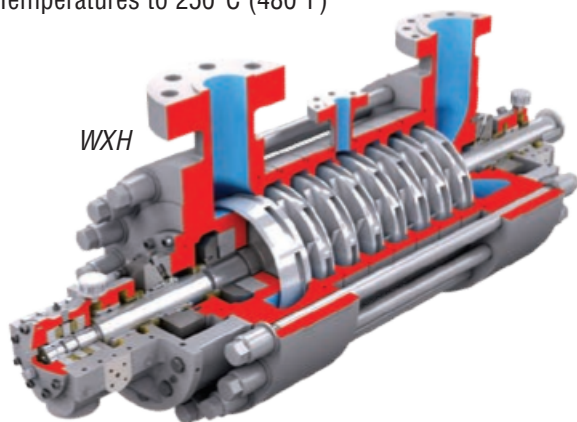

Vertical, Single- and Multistage, Double Case

Operating Parameters

- Flows to 25 000 m³/h (110 000 gpm)
- Heads to 1070 m (3500 ft)
- Pressures to 100 bar (1450 psi)
- Temperatures to 230°C (450°F)

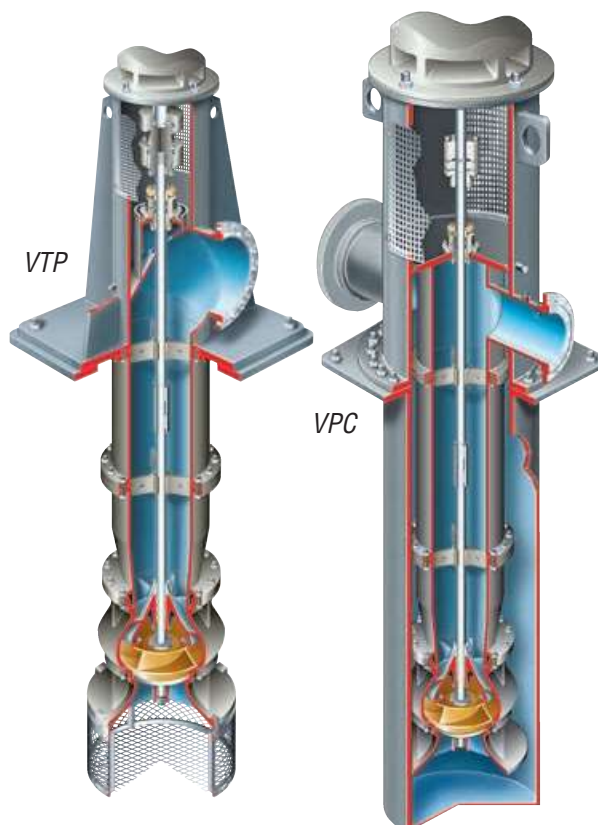



Life Cycle Cost Solutions

Typically, 90% of the total life cycle cost (LCC) of a pumping system is accumulated after the equipment is purchased and installed. Flowserve has developed a comprehensive suite of solutions aimed at providing customers with unprecedented value and cost savings throughout the life span of the pumping system. These solutions account for every facet of life cycle cost, including:

- Capital Expenses
 - Initial purchase
 - Installation
- Operating Expenses
 - Energy consumption
 - Maintenance
 - Production losses
 - Environmental
 - Inventory
 - Operating
 - Removal



Typical Pump Life Cycle Costs¹

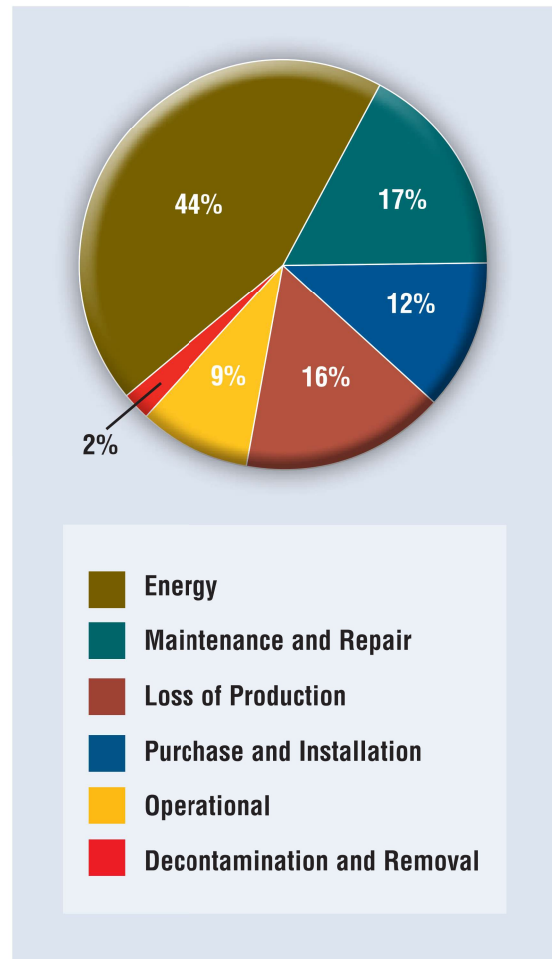

¹ While exact values may differ, these percentages are consistent with those published by leading pump manufacturers and end users, as well as industry associations and government agencies worldwide.



Innovative Life Cycle Cost Programs

New Pump Selection

FlowsERVE provides front-end consulting services that balance initial procurement cost with longer-term operational concerns, including equipment reliability and energy consumption. Proper upfront selection of a high-efficiency, high-energy pump can literally save millions of dollars in operating costs over the life of the system.

Turnkey Engineering and Field Service

FlowsERVE offers turnkey engineering capabilities to streamline capital expenses related to piping design, foundation engineering, electrical systems and instrumentation. FlowsERVE technicians can offer installation and commissioning solutions that significantly reduce installation time such as advanced laser alignment and ungrouted foundation solutions.

Energy Management

Pumping systems can comprise between 20% and 50% of energy usage in typical industrial plants and as much as 95% in pipeline systems. On behalf of its customers, FlowsERVE actively pursues hydraulic re-rates, pump upgrades and system enhancements that offer energy savings between 30% and 50% of existing levels. A typical improvement program may involve field assessments, analytical modeling and investment recommendations.

Pump Availability

FlowsERVE engineers and technicians have been specially trained to help customers analyze, diagnose and solve those issues that cause problematic pump breakdowns and unscheduled outages. Engineers are equipped to collect real-time data, review performance problems, analyze data, and make recommendations that result in improved pump system availability and higher profits.

Proactive Maintenance

FlowsERVE technicians are trained to provide services that go beyond simple reactive maintenance and repair. By analyzing failure modes, FlowsERVE can offer upgrades ranging from materials and coatings upgrades to hydraulic re-rates — all aimed at increasing pump reliability.

Inventory Management

Programs that help standardize materials, maximize interchangeability, and increase part and assembly availability can have a significant impact on costs associated with spare parts inventory. Asset management experts from FlowsERVE can offer customized programs that reduce inventory levels while ensuring availability of critical parts.



Bulletin FPD-5h (E/A4) February 2015. © 2015 Flowserve Corporation

To find your local Flowserve representative:

**Компания ПромХимТех-
официальный дистрибьютор
насосов Flowserve
www.promhimtech.ru
Тел. 8 800 250-01-54
e-mail: zakaz@promhimtech.ru**

USA and Canada

Flowserve Corporation
5215 North O'Connor Blvd.
Suite 2300
Irving, Texas 75039-5421 USA
Telephone: +1 937 890 5839

Europe, Middle East, Africa

Flowserve Corporation
Parallelweg 13
4878 AH Etten-Leur
The Netherlands
Telephone: +31 76 502 8100

Latin America

Flowserve Corporation
Martín Rodríguez 4460
B1644CGN-Victoria-San Fernando
Buenos Aires, Argentina
Telephone: +54 11 4006 8700
Telefax: +54 11 4714 1610

Asia Pacific

Flowserve Pte. Ltd.
10 Tuas Loop
Singapore 637345
Telephone: +65 6771 0600
Telefax: +65 6862 2329