



Компания ПромХимТех-  
официальный дистрибьютор  
насосов Flowserve  
www.promhimtech.ru  
Тел. 8 800 250-01-54  
e-mail: zakaz@promhimtech.ru

## *Pumping Solutions for Sump Applications*



### ***Leader in Flow Management***

*Flowserve is one of the world's leading providers of fluid motion and control products and services. Operating in more than 55 countries, the company produces engineered and industrial pumps, seals and valves as well as a range of related flow management services.*

### ***Flowserve offers a wide range of pumping solutions for sump services.***

Whether it is for petroleum, chemical, mining, metals, paper or general industries, Flowserve has the pump for any sump service. Typical applications include:

- Mixed chemical wastes
- Waste acid transfer
- Abrasive slurries
- Fly ash pond transfer
- Stringy or fibrous slurries
- Effluent
- Water treatment
- Dirty water
- Waste treatment lagoon service
- Run-off
- Low-NPSH available sump services
- High discharge heads



***Experience In Motion***

*Flowserve has the pump for any sump service.*

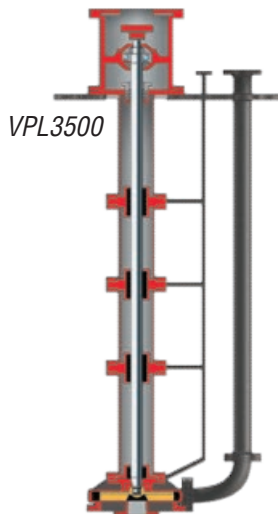
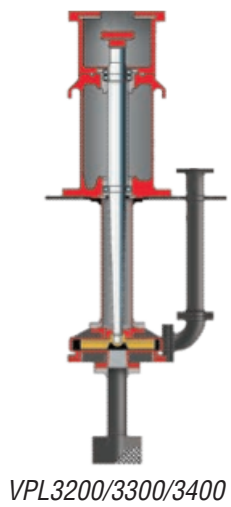
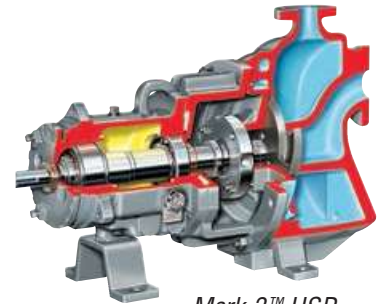
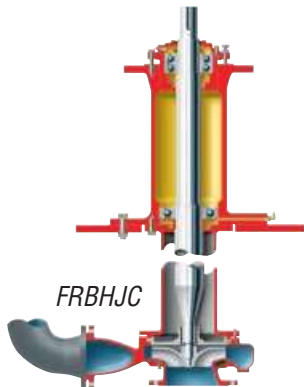
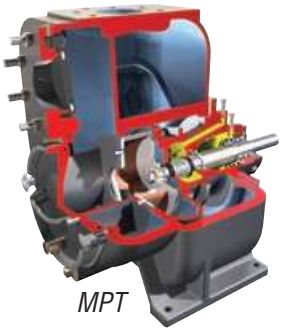
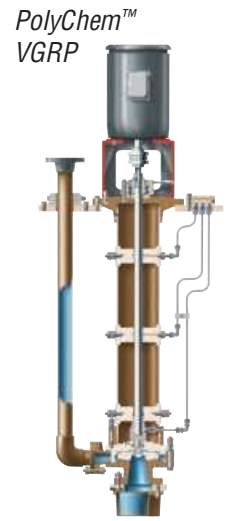
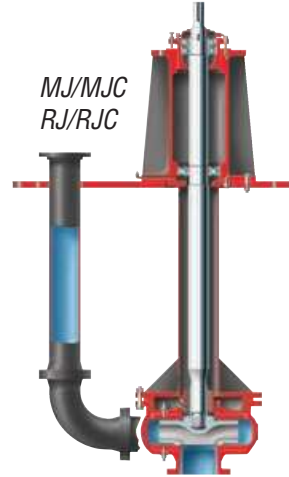

Pump Model	Flows to	Heads to	Pressure to	Max Temperature	Product Description
<b>CPXV</b>	1400 m <sup>3</sup> /h (6160 gpm)	250 m (820 ft)	25 bar (365 psi)	400°C (752°F)	ISO 5199 compliant design with ISO 13709/API 610 features
<b>ECPJ</b>	1000 m <sup>3</sup> /h (4400 gpm)	150 m (500 ft)	20 bar (285 psi)	350°C (660°F)	Lineshaft bearing designed to ISO 13709/API 610 VS4 requirements
<b>ESP3</b>	1300 m <sup>3</sup> /h (5700 gpm)	90 m (300 ft)	12 bar (175 psi)	180°C (350°F)	Lineshaft bearing design; wet-end parts interchangeable with Mark 3 ASME B73.1 pumps
<b>FRBHJC</b>	2700 m <sup>3</sup> /h (12 000 gpm)	100 m (330 ft)	14 bar (200 psi)	150°C (300°F)	True stiff shaft cantilever design, without bottom bearing or flushing water
<b>Mark 3 ISO Self-Priming</b>	100 m <sup>3</sup> /h (440 gpm)	100 m (330 ft)	25 bar (365 psi)	400°C (752°F)	Self-priming, ATEX certified, CE marked
<b>Mark 3 Unitized Self-Primer</b>	320 m <sup>3</sup> /h (1400 gpm)	120 m (400 ft)	20 bar (285 psi)	370°C (700°F)	Self-priming ASME type; multiple wet-end alloys available
<b>MJ/MJC RJ/RJC</b>	1350 m <sup>3</sup> /h (6000 gpm)	30 m (100 ft)	10 bar (150 psi)	110°C (225°F)	MJ: hard metal. RJ: rubber-lined. Direct coupled or “V” belt driven
<b>MPT</b>	600 m <sup>3</sup> /h (2650 gpm)	35 m (115 ft)	5 bar (72 psi)	75°C (165°F)	Self-priming, solids handling design
<b>PolyChem VGRP</b>	565 m <sup>3</sup> /h (2500 gpm)	110 m (350 ft)	17 bar (250 psi)	90°C (200°F)	Glass-reinforced vinyl ester design for general industrial use
<b>Terra-Titan</b>	250 m <sup>3</sup> /h (1100 gpm)	45 m (150 ft)	5 bar (70 psi)	100°C (212°F)	Cantilever design with hard-metal or urethane wet-end
<b>VPL1700</b>	182 m <sup>3</sup> /h (800 gpm)	244 m (800 ft)	21 bar (300 psi)	52°C (125°F)	Multistage, vertical, toxic liquid, emergency seal
<b>VPL3200</b>	4542 m <sup>3</sup> /h (20 000 gpm)	91 m (300 ft)	21 bar (300 psi)	149°C (300°F)	Cantilever, dry-run capability
<b>VPL3300</b>	1500 m <sup>3</sup> /h (6600 gpm)	91 m (300 ft)	21 bar (300 psi)	149°C (300°F)	Cantilever, volatile organic compounds
<b>VPL3400</b>	1500 m <sup>3</sup> /h (6600 gpm)	91 m (300 ft)	21 bar (300 psi)	593°C (1100°F)	Molten salt transfer
<b>VPL3500</b>	4542 m <sup>3</sup> /h (20 000 gpm)	150 m (492 ft)	21 bar (300 psi)	100°C (212°F)	Single-stage vertical lineshaft, ISO 13709/API 610 (VS4) compliant
<b>VPL3600</b>	1500 m <sup>3</sup> /h (6600 gpm)	150 m (492 ft)	21 bar (300 psi)	100°C (212°F)	Vertical lineshaft, slurry impeller, custom shaft length, ISO 13709/API 610 (VS4) compliant



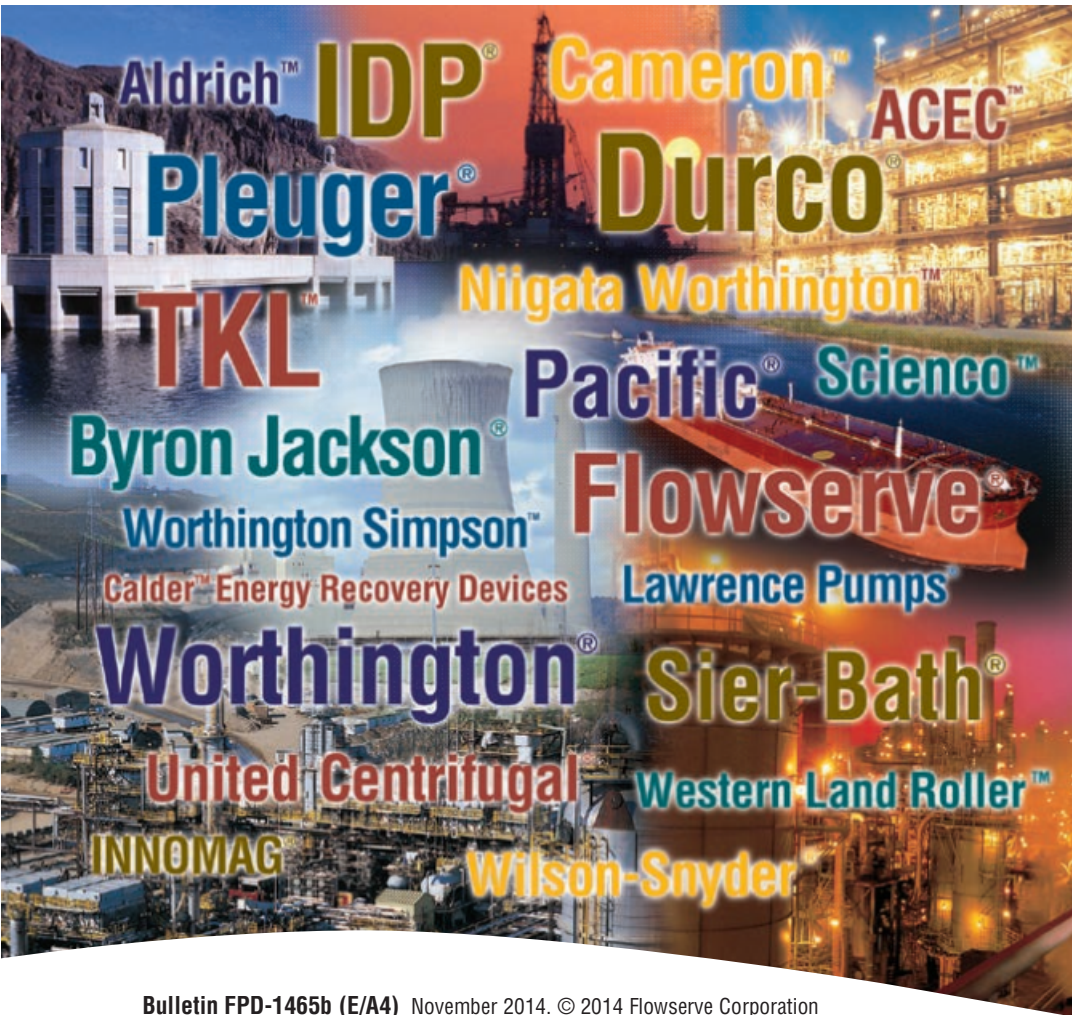

Bulletin FPD-1465b (E/A4) November 2014. © 2014 Flowserve Corporation

*To find your local Flowserve representative:*

**Компания ПромХимТех-  
официальный дистрибьютор  
насосов Flowserve  
[www.promhimtech.ru](http://www.promhimtech.ru)  
Тел. 8 800 250-01-54  
e-mail: [zakaz@promhimtech.ru](mailto:zakaz@promhimtech.ru)**

**USA and Canada**

Flowserve Corporation  
5215 North O'Connor Blvd.  
Suite 2300  
Irving, Texas 75039-5421 USA  
Telephone: +1 937 890 5839

**Europe, Middle East, Africa**

Flowserve Corporation  
Parallelweg 13  
4878 AH Etten-Leur  
The Netherlands  
Telephone: +31 76 502 8100

**Latin America**

Flowserve Corporation  
Martín Rodríguez 4460  
B1644CGN-Victoria-San Fernando  
Buenos Aires, Argentina  
Telephone: +54 11 4006 8700  
Telefax: +54 11 4714 1610

**Asia Pacific**

Flowserve Pte. Ltd.  
10 Tuas Loop  
Singapore 637345  
Telephone: +65 6771 0600  
Telefax: +65 6862 2329