

50 Hz

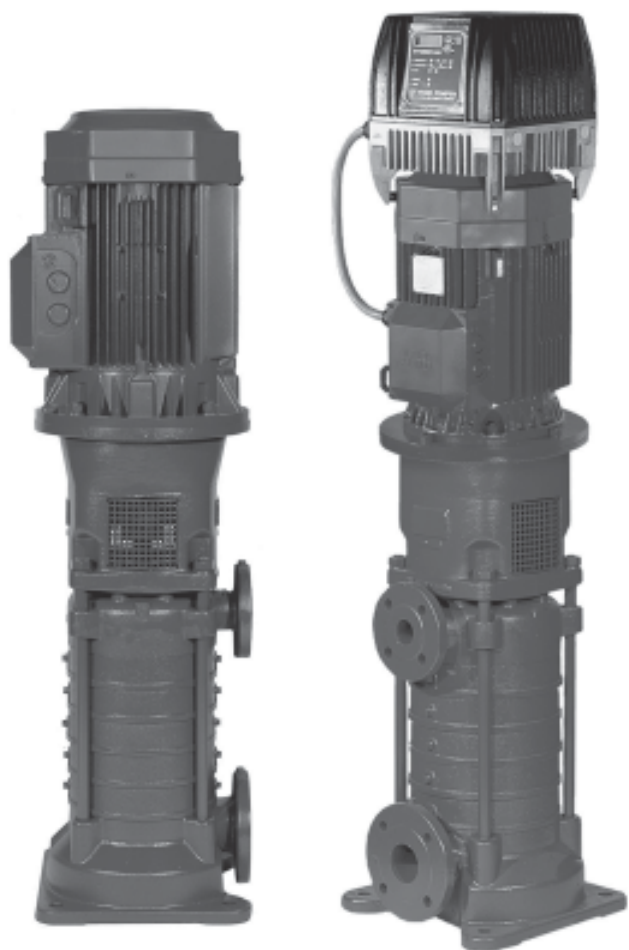

TDB - TDV Series

TBD 22, 35, 58, 78, 120, 170

TDV 120, 170, 220, 280

VERTICAL MULTISTAGE ELECTRIC PUMPS EQUIPPED WITH
IE2 MOTORS COMPLYING WITH REGULATION (EC) no. 640/2009

Cod. 191002201 Rev.A Ed.12/2011

 **LOWARA**
a xylem brand

**TDB - TDV SERIES
HYDRAULIC PERFORMANCE RANGE AT 50 Hz**

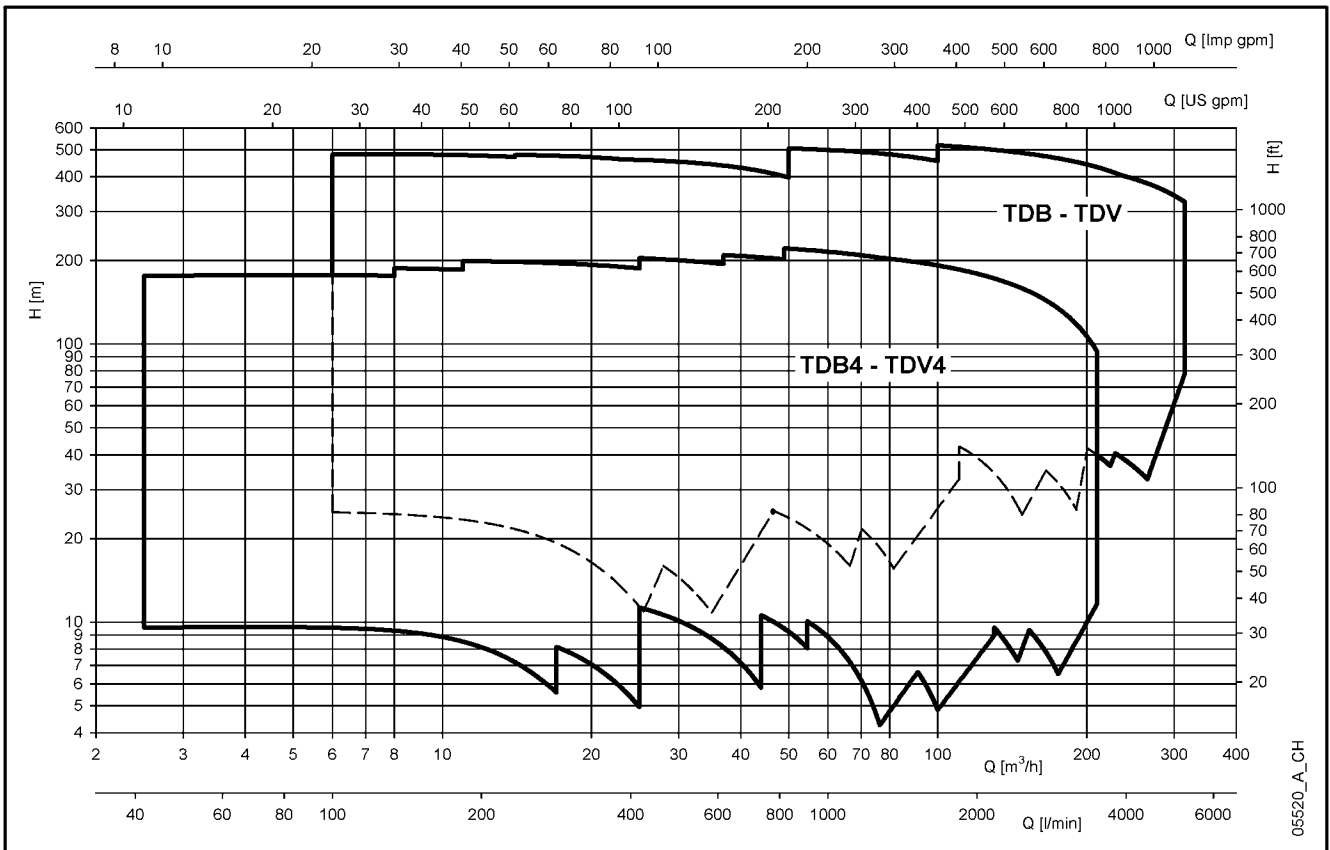

CONTENTS

Pump characteristics	5
Series characteristics	6
General characteristics	7
Typical applications	8
TDB electric pumps and main components	10
TDV electric pumps and main components	12
TDB-TDV mechanical seals	14
Motors	15
Hydraulic performance at 50 Hz, 2 poles	21
Hydraulic performance at 50 Hz, 4 poles	28
Operating characteristics at 50 Hz, 2 poles	33
Operating characteristics at 50 Hz, 4 poles	52
Dimensions and weights	61
Dimensions and weights at 50 Hz, 4 poles	78
Technical appendix	87
Pressure-temperature limits	88
Forces and moments on sleeves	89
Rating plate	90
Moments of inertia	91
Mechanical seal selection diagrams	93
Fixing bolts and torque setting	95

Vertical multistage electric pumps

TDB - TDV Series

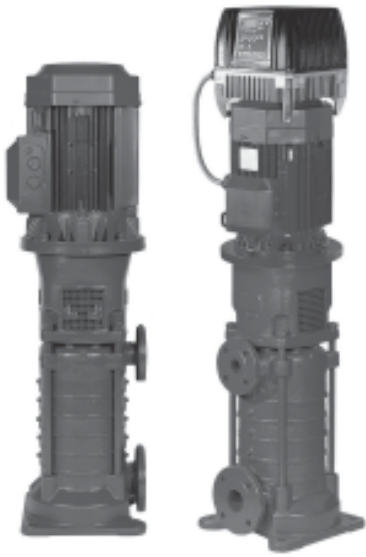

- EIGHT SIZES:**
TDB-TDV22, 35, 58, 78, 120, 170, 220, 280
- FLOW RATE UP TO 340 m³/h**
- HEAD OVER 500 m**
- STANDARD MECHANICAL SEAL**
- NORMALISED STANDARD MOTOR**
- MODULAR CONSTRUCTION FOR OPTIMISED INTERCHANGEABILITY OF COMPONENTS**
- DIFFUSERS SEPARATE FROM STAGE CASINGS**
- OPERATING FLEXIBILITY WITH HYDROVAR® CONTROL SYSTEM**

MARKET SECTORS

CIVIL, INDUSTRIAL, WATER TREATMENT, HEATING, PRESSURISATION, IRRIGATION.

APPLICATIONS

- Handling water without suspended solids.
- Pressure boosting and water supply systems.
- Irrigation systems.
- Cooling circuits.
- Circulation of hot and cold water for heating, cooling and conditioning systems.
- Water supplies to boilers.
- Reverse osmosis and ultra-filtration.
- Fire-fighting.
- Washing systems.

PUMP CHARACTERISTICS

PUMP

- Vertical multistage pump fitted with closed radial impellers driven by a normalised standard motor. The pump is available in various materials and configurations and in two versions with the denomination TDB and TDV.
- **Delivery:** up to 340 m³/h.
- **Head:** over 500 m.
- **Temperature** of pumped liquid: - up to 140 °C in the standard version.
- Maximum operating **pressure:** round flanges PN10/16, PN25/40, PN63 depending on the model.
- Tested to ISO 9906 class 2.
- Direction of rotation: clockwise looking at the pump from the motor side.

MATERIALS

- **Version F:** totally made from cast iron with cast iron impellers.
- **Version FB:** totally made from cast iron with bronze impellers.
- **Version N:** totally made from AISI CF8M stainless steel.
- Other materials available on request.

MOTOR

- Short circuit squirrel cage motor, totally enclosed, fan-cooled.
- **Standard supplied IE2 motors are compliant with Regulation (EC) no. 640/2009 and IEC 60034-30.**
- IP 55 protection.
- Class 155 (F) insulation.
- Performances according to EN 60034-1.
- **Standard voltage:**
Three-phase version:
220-240/380-415 V, 50 Hz for powers up to 3 kW,
380-415/660-690 V, 50 Hz for powers above 3 kW.

CHARACTERISTICS OF TDB 22,35,58,78,120,170 SERIES

- Vertical multistage pump with radial impellers.
- **TDB** construction features:
 1. Suction body with radial inlet.
 2. Pump integral with motor.
 3. Normalised standard motor according to IEC, layout V1.
 4. Motor power outputs up to 90 kW.
 5. Axial thrust absorbed by motor bearings.
- **Version F** (standard): intermediate stages with external shell in cast iron, diffusers and impellers in cast iron.
- **Version FB**: intermediate stages with external shell in cast iron, diffusers in cast iron and impellers in bronze.
- **Version N**: totally made from AISI CF8M (molten AISI 316) stainless steel.
- Radial slide bearings in suction body, liquid-lubricated.
- Standard mechanical seal according to EN 12756 (version k), balanced or unbalanced depending on the model.
- Seal chamber dimensions according to ISO 3069.
- Inlets fitted with round flanges PN10/16, PN25/40 and PN63 depending on the type of pump.
- Standard version for temperatures up to 140 °C.

CHARACTERISTICS OF TDV 120,170,220,280 SERIES

- Vertical multistage pump with radial impellers.
- **TDV** construction features :
 1. Suction body with radial intake.
 2. Power transmission through elastic coupling.
 3. Normalised standard motor according to IEC, layout V1.
 4. Motor power outputs from 90 to 355 kW.
 5. Grease-lubricated axial bearing; lubricator with threaded connectors.
- **Version F** (standard): intermediate stages with external shell in cast iron, diffusers and impellers in cast iron.
- **Version FB**: intermediate stages with external shell in cast iron, diffusers in cast iron and impellers in bronze.
- **Version N**: totally made from AISI CF8M (molten AISI 316) stainless steel.
- Radial slide bearings in suction body, liquid-lubricated.
- Standard mechanical seal according to EN 12756 (version k), balanced or unbalanced depending on the model.
- Seal chamber dimensions according to ISO 3069.
- Inlets fitted with round flanges PN10/16, PN25/40 and PN63 depending on the type of pump.
- Standard version for temperatures up to 140 °C.

CONFIGURATIONS ON REQUEST

- Special voltages and frequencies.
- Different positions of inlets and motor terminal board.
- Special materials for pump, mechanical seal, elastomers and gaskets.

GENERAL CHARACTERISTICS TDB-TDV 2 POLES

	TDB22	TDB35	TDB58	TDB78	TDB120 TDV120	TDB170 TDV170	TDV220	TDV280
Max. efficiency flow (m³/h)	22	35	58	78	120	170	220	280
Flow range (m³/h)	6÷32	6÷45	10÷75	13÷105	20÷155	29÷210	70÷260	110÷310
Maximum pressure (bar)	48	47	47	35	22 51	18 40	55	50
Motor power (kW)	2,2÷55	3÷75	7,5÷90	7,5÷90	22÷90 110÷200	30÷90 110÷200	45÷355	45÷355
max η (%) of pump	60	66	70	74	76,5	78	78	78
Standard temperature (°C)	-10 +140							

tdb-tdv_2p50-en_a_tg

TDB-TDV 4 POLES

	TDB22	TDB35	TDB58	TDB78	TDB120	TDB170 TDV170	TDV220	TDV280
Max. efficiency flow (m³/h)	11	18	28	39	60	85	110	140
Flow range (m³/h)	2÷16	2÷24	5÷38	7÷55	10÷80	14÷110	35÷140	54÷190
Maximum pressure (bar)	17	17,5	18,5	20	20,5	21 22	21	21
Motor power (kW)	1,1÷11	1,1÷15	2,2÷22	2,2÷30	11÷45	11÷55 75	11÷90	11÷90
max η (%) of pump	58	64	67	72	72,5	77	76	77
Standard temperature (°C)	-10 +140							

tdb-tdv_4p50-en_a_tg

STANDARD VERSIONS TDB-TDV, 2 and 4 POLES

TYPE	SUCTION BODY	DELIVERY BODY	INTERMED. STAGES	DIFFUSERS	IMPELLERS	CONNECTIONS	TDB	TDB	TDB	TDB	TDB	TDB	TDB	TDB
							22	35	58	78	120	170	220	280
F	CAST IRON GG25	CAST IRON GG25(*)	CAST IRON GG25	CAST IRON GG25	CAST IRON GG25	INLETS FITTED WITH ROUND FLANGES	•	•	•	•	•	•	•	•
FB	CAST IRON GG25	CAST IRON GG25(*)	CAST IRON GG25	CAST IRON GG25	BRONZE G-CuSn10		•	•	•	•	•	•	•	•
N	STAINLESS STEEL AISI CF8M						•	•	•	•	•	•	•	•

(•) : FOR DELIVERY PRESSURES HIGHER THAN 40bar. THE DELIVERY BODY IS MADE FROM MODULAR CAST IRON GGG40

tdb-tdv-std_2p-4p-en_a_tg

OTHER VERSIONS TDB-TDV, 2 and 4 POLES (ON REQUEST)

TYPE	SUCTION BODY	DELIVERY BODY	INTERMED. STAGES	DIFFUSERS	IMPELLERS	CONNECTIONS	TDB	TDB	TDB	TDB	TDB	TDB	TDB	TDB
							22	35	58	78	120	170	220	280
FN	CAST IRON GG25	CAST IRON GG25(*)	CAST IRON GG25	CAST IRON GG25	STAINLESS STEEL AISICF8M	INLETS FITTED WITH ROUND FLANGES	•	•	•	•	•	•	•	•
DF	CAST IRON GGG40	CAST IRON GGG40	CAST IRON GGG40	CAST IRON GG25	CAST IRON GG25		•	•	•	•	•	•	•	•
DN	CAST IRON GGG40	CAST IRON GGG40	CAST IRON GGG40	CAST IRON GG25	STAINLESS STEEL AISICF8M		•	•	•	•	•	•	•	•
GF	CAST STEEL GS-C25	CAST STEEL GS-C25	CAST STEEL GS-C25	CAST IRON GG25	CAST IRON GG25		•	•	•	•	•	•	•	•
GN	CAST STEEL GS-C25	CAST STEEL GS-C25	CAST STEEL GS-C25	CAST IRON GG25	STAINLESS STEEL AISICF8M		•	•	•	•	•	•	•	•

(•) : FOR DELIVERY PRESSURES HIGHER THAN 40bar. THE DELIVERY BODY IS MADE FROM MODULAR CAST IRON GGG40

tdb-tdv-av_2p-4p-en_a_tg

VERSION DIAGRAM

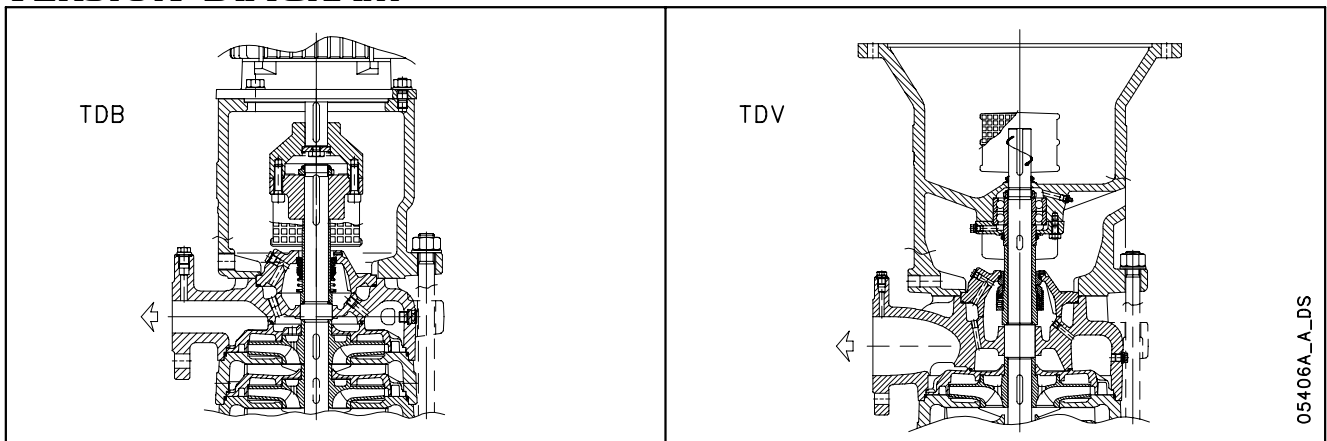

TYPICAL APPLICATIONS

Water supply and pressure boosting

- Pressure boosting in buildings and hotels.
- Pressure booster stations, water network supplies.
- Booster packages.

Water treatment

- Ultra-filtration systems.
- Reverse osmosis systems.
- Filtration.

Industry

- Washing and cleaning plants.
- Cooling circuits.
- Mining industry.

Irrigation

- Sprinkler irrigation.

Heating, ventilation and air-conditioning

- Cooling towers.
- Refrigerators.
- Heat exchangers.
- Boilers.
- Artificial snow generators.

Main pumped liquids

- Clean liquids in general.
- Hot and cold water.
- Condensates.
- Oil-based suspensions.
- Acid or basic aqueous solutions.

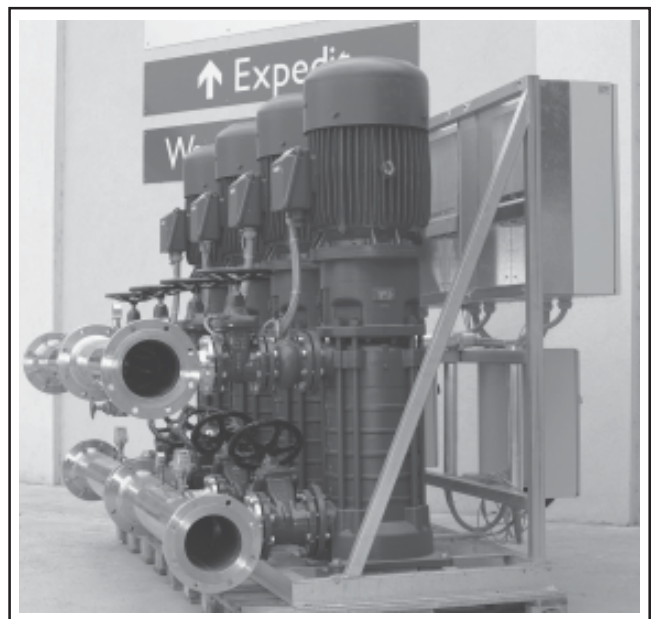
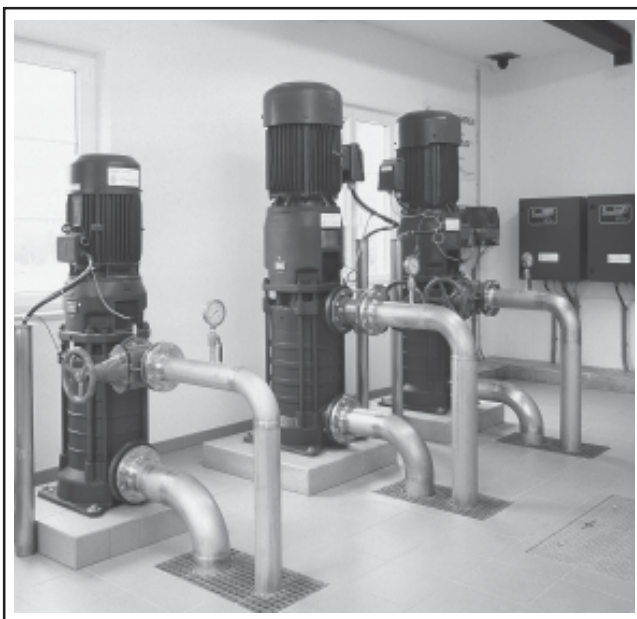
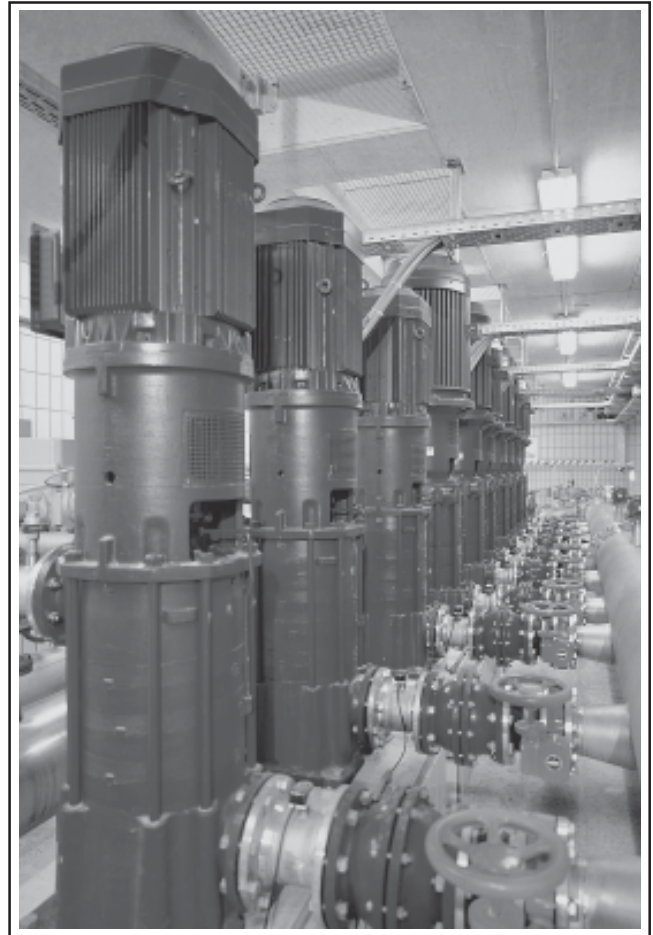

TDB22,35,58,78,120,170 - TDV120,170,220,280 SERIES ELECTRIC PUMP IDENTIFICATION CODE

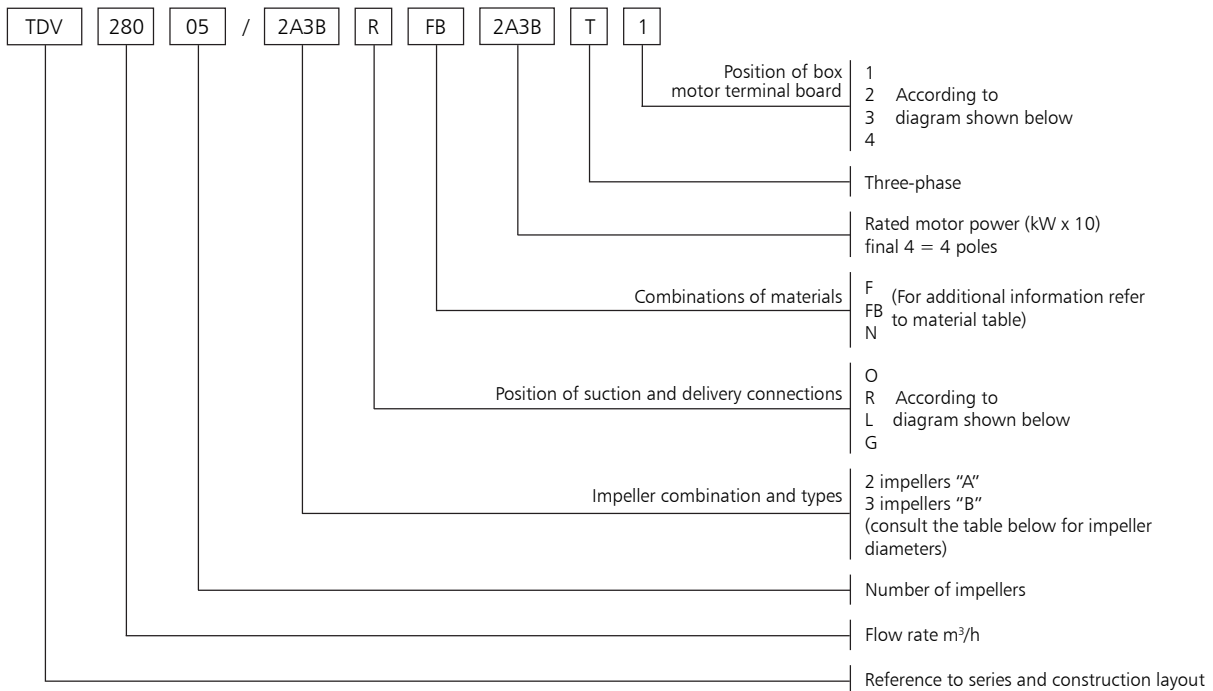

ELECTRIC PUMPS TDB / TDV HYDRAULIC TYPE	IMPELLER DIAMETERS (mm) BY HYDRAULIC TYPE			
	IMPELLER A	IMPELLER B	IMPELLER C	IMPELLER D
22 - 35	170	150	130	-
58 - 78	200	178	155	-
120 - 170	240	220	200	-
220 - 280	275	255	235	215

tdb-tdv_2p50-en_a_ti

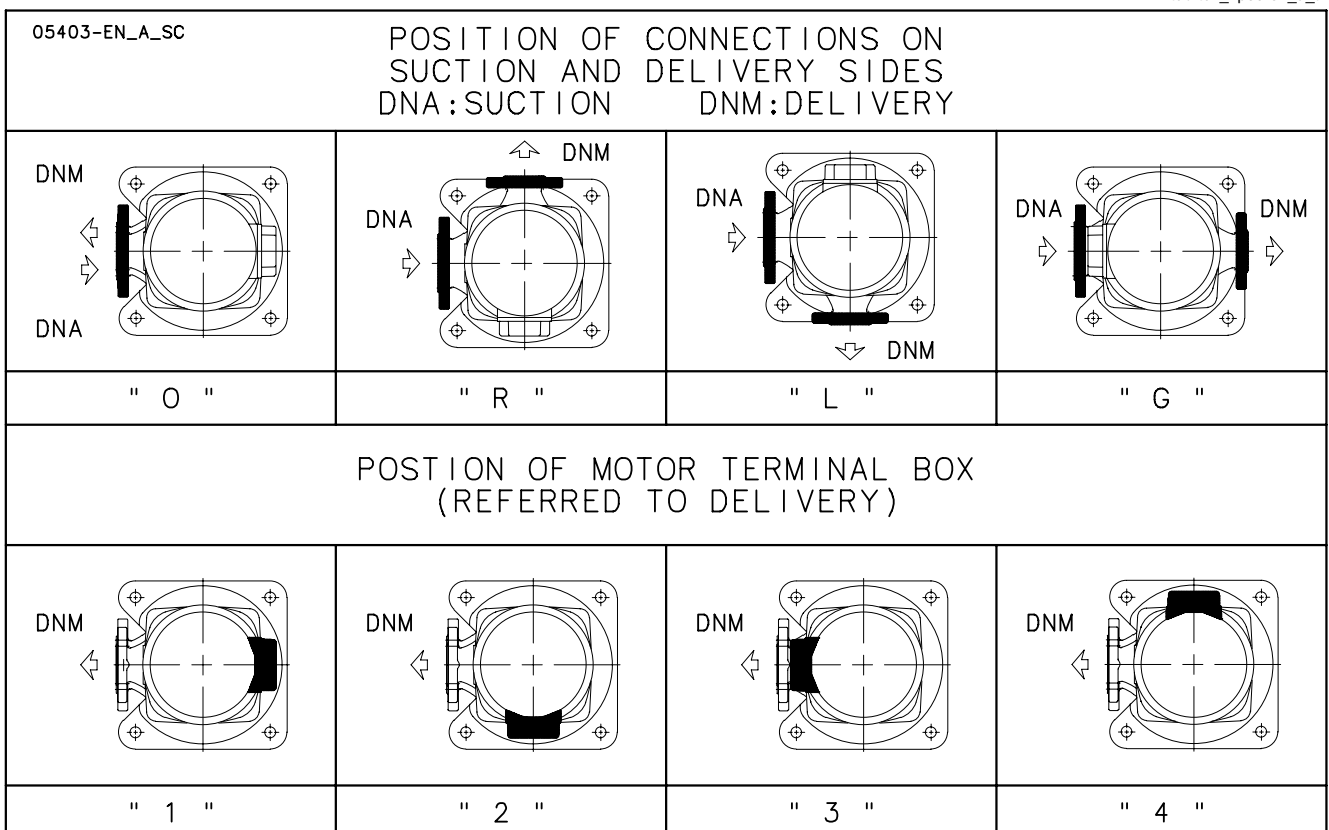

**TDB 22,35,58,78,120,170 SERIES
PUMP CROSS-SECTION AND MAIN COMPONENTS**

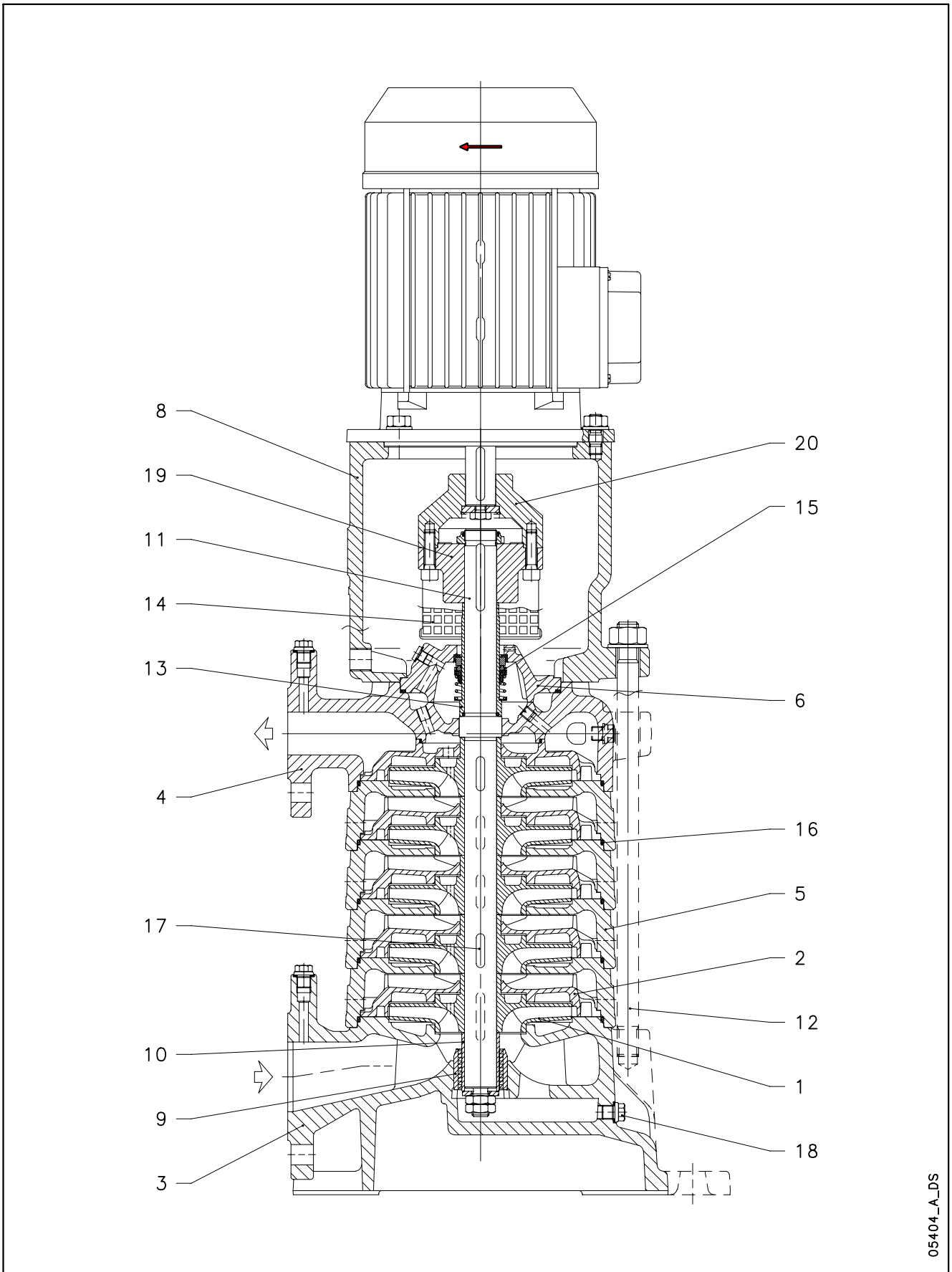

05404_A_DS

TDB 22,35,58,78,120,170 SERIES TABLE OF MATERIALS VERSION F

N°	NAME	MATERIAL	REFERENCE STANDARDS	
			EUROPE	USA
1	Impeller	Cast iron	EN 1561-GJL-250 (JL1040)	ASTM A4876-Class 35B
2	Diffusers	Cast iron	EN 1561-GJL-250 (JL1040)	ASTM A4876-Class 35B
3	suction body	Cast iron	EN 1561-GJL-250 (JL1040)	ASTM A4876-Class 35B
4	delivery body	Cast iron	EN 1561-GJL-250 (JL1040)	ASTM A4876-Class 35B
	delivery body PN63	Cast iron	EN 1563-GJS-400-15 (JS1072)	ASTM A536-60-40-18
5	Stage casing	Cast iron	EN 1561-GJL-250 (JL1040)	ASTM A4876-Class 35B
6	Seal cover	Cast iron	EN 1561-GJL-250 (JL1040)	ASTM A4876-Class 35B
7	Bearing cover	Cast iron	EN 1561-GJL-250 (JL1040)	ASTM A4876-Class 35B
8	Motor support	Cast iron	EN 1561-GJL-250 (JL1040)	ASTM A4876-Class 35B
9	Bushing	Bronze	G-CuSn16	
10	Shaft sleeve for bushing	Stainless steel	EN 10088-1-X20Cr13 (1.4021)	AISI 420
11	Shaft	Stainless steel	EN 10088-1-X20Cr13 (1.4021)	AISI 420
12	Tie-rod	Carbon steel	EN ISO 898-1 8.8	F568 - Class 8.8
13	Shaft sleeve for seal	Stainless steel	EN 10088-1-X20Cr13 (1.4021)	AISI 420
14	Coupling protection	Carbon steel	EN 10025-S235JRG2 (1.0038)	A570 - Grade 36
15	Mechanical seal	Carburundum / resin-impregnated carbon / EPDM (standard version)		
16	Elastomers	EPDM (standard version)		
17	Keys	Carbon steel	EN 10083-1-C45E(1.1191)	A576 - Grade 1042
18	Plugs	Carbon steel	EN ISO 898-1 5.8	A568 - Class 5.8
19	Pump side semi-coupling	Cast iron	EN 1563-GJS-400-15 (JS1072)	ASTM A536-60-40-18
20	Motor side semi-coupling	Cast iron	EN 1561-GJL-250 (JL1040)	ASTM A4876-Class 35B

td_tdb-f-en_a_tm

TABLE OF MATERIALS VERSION FB

N°	NAME	MATERIAL	REFERENCE STANDARDS	
			EUROPE	USA
1	Impeller	Bronze	EN 1982-G-CuSn10-C (CC480K)	UNS C90700
2	Diffusers	Cast iron	EN 1561-GJL-250 (JL1040)	ASTM A4876-Class 35B
3	suction body	Cast iron	EN 1561-GJL-250 (JL1040)	ASTM A4876-Class 35B
4	delivery body	Cast iron	EN 1561-GJL-250 (JL1040)	ASTM A4876-Class 35B
	delivery body PN63	Cast iron	EN 1563-GJS-400-15 (JS1072)	ASTM A536-60-40-18
5	Stage casing	Cast iron	EN 1561-GJL-250 (JL1040)	ASTM A4876-Class 35B
6	Seal cover	Cast iron	EN 1561-GJL-250 (JL1040)	ASTM A4876-Class 35B
7	Bearing cover	Cast iron	EN 1561-GJL-250 (JL1040)	ASTM A4876-Class 35B
8	Motor support	Cast iron	EN 1561-GJL-250 (JL1040)	ASTM A4876-Class 35B
9	Bushing	Bronze	G-CuSn16	
10	Shaft sleeve for bushing	Stainless steel	EN 10088-1-X20Cr13 (1.4021)	AISI 420
11	Shaft	Stainless steel	EN 10088-1-X20Cr13 (1.4021)	AISI 420
12	Tie-rod	Carbon steel	EN ISO 898-1 8.8	F568 - Class 8.8
13	Shaft sleeve for seal	Stainless steel	EN 10088-1-X20Cr13 (1.4021)	AISI 420
14	Coupling protection	Carbon steel	EN 10025-S235JRG2 (1.0038)	A570 - Grade 36
15	Mechanical seal	Carburundum / resin-impregnated carbon / EPDM (standard version)		
16	Elastomers	EPDM (standard version)		
17	Keys	Carbon steel	EN 10083-1-C45E(1.1191)	A576 - Grade 1042
18	Plugs	Carbon steel	EN ISO 898-1 5.8	A568 - Class 5.8
19	Pump side semi-coupling	Cast iron	EN 1563-GJS-400-15 (JS1072)	ASTM A536-60-40-18
20	Motor side semi-coupling	Cast iron	EN 1561-GJL-250 (JL1040)	ASTM A4876-Class 35B

td_tdb-fb-en_a_tm

TABLE OF MATERIALS VERSION N

N°	NAME	MATERIAL	REFERENCE STANDARDS	
			EUROPE	USA
1	Impeller	Stainless steel	EN 10213-4-GX5CrNiMo19-11-2 (1.4408)	ASTM CF8M (AISI316 cast)
2	Diffusers	Stainless steel	EN 10213-4-GX5CrNiMo19-11-2 (1.4408)	ASTM CF8M (AISI316 cast)
3	suction body	Stainless steel	EN 10213-4-GX5CrNiMo19-11-2 (1.4408)	ASTM CF8M (AISI316 cast)
4	delivry body	Stainless steel	EN 10213-4-GX5CrNiMo19-11-2 (1.4408)	ASTM CF8M (AISI316 cast)
5	Stage casing	Stainless steel	EN 10213-4-GX5CrNiMo19-11-2 (1.4408)	ASTM CF8M (AISI316 cast)
6	Seal cover	Stainless steel	EN 10213-4-GX5CrNiMo19-11-2 (1.4408)	ASTM CF8M (AISI316 cast)
7	Bearing cover	Cast iron	EN 1561-GJL-250 (JL1040)	ASTM A4876-Class 35B
8	Motor support	Cast iron	EN 1561-GJL-250 (JL1040)	ASTM A4876-Class 35B
9	Bushing	Bronze	G-CuSn16	
10	Shaft sleeve for bushing	Stainless steel	EN 10088-1-X2CrNiMoN22-5-3 (1.4462)	AISI 329 LN - S31803
11	Shaft	Stainless steel	EN 10088-1-X2CrNiMoN22-5-3 (1.4462)	AISI 329 LN - S31803
12	Tie-rod	Carbon steel	EN ISO 898-1 8.8	F568 - Class 8.8
13	Shaft sleeve for seal	Stainless steel	EN 10088-1-X20Cr13 (1.4021)	AISI 420
14	Coupling protection	Carbon steel	EN 10025-S235JRG2 (1.0038)	A570 - Grade 36
15	Mechanical seal	Carburundum / resin-impregnated carbon / EPDM (standard version)		
16	Elastomers	EPDM (standard version)		
17	Keys	Stainless steel	EN 10088-2-X6CrNiMoTi17-12-1 (1.4571)	A276 - Typ 316T i
18	Plugs	Stainless steel	EN 10088-2-X6CrNiMoTi17-12-1 (1.4571)	A276 - Typ 316T i
19	Pump side semi-coupling	Cast iron	EN 1563-GJS-400-15 (JS1072)	ASTM A536-60-40-18
20	Motor side semi-coupling	Cast iron	EN 1561-GJL-250 (JL1040)	ASTM A4876-Class 35B

td_tdb-n-en_a_tm

**TDV 120,170,220,280 SERIES
PUMP CROSS-SECTION AND MAIN COMPONENTS**

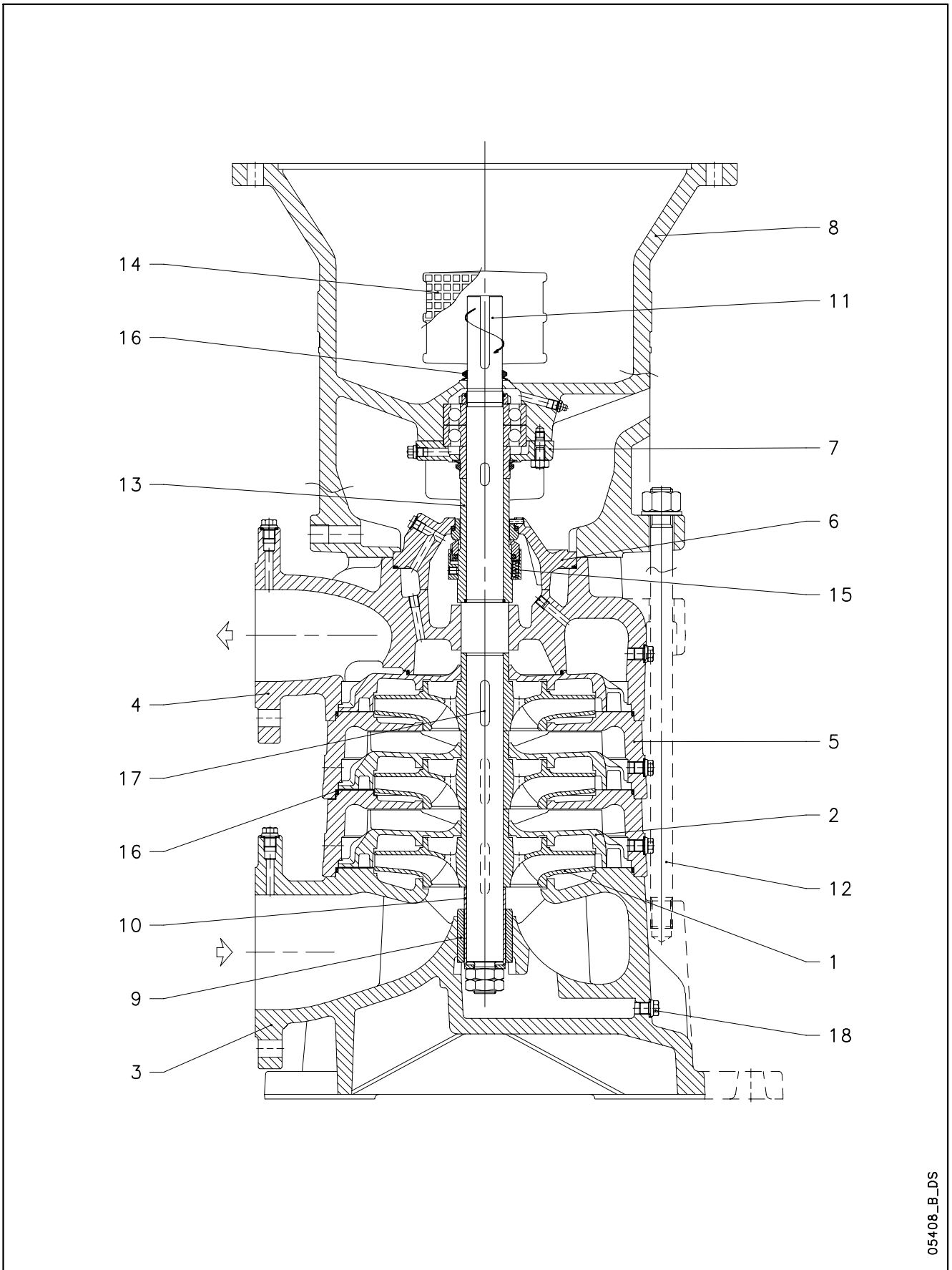

05408_B_DS

TDV 120,170,220,280 SERIES TABLE OF MATERIALS VERSION F

N°	NAME	MATERIAL	REFERENCE STANDARDS	
			EUROPE	USA
1	Impeller	Cast iron	EN 1561-GJL-250 (JL1040)	ASTM A4876-Class 35B
2	Diffusers	Cast iron	EN 1561-GJL-250 (JL1040)	ASTM A4876-Class 35B
3	sunction body	Cast iron	EN 1561-GJL-250 (JL1040)	ASTM A4876-Class 35B
4	delivery body	Cast iron	EN 1561-GJL-250 (JL1040)	ASTM A4876-Class 35B
	delivery body PN63	Cast iron	EN 1563-GJS-400-15 (JS1072)	ASTM A536-60-40-18
5	Stage casing	Cast iron	EN 1561-GJL-250 (JL1040)	ASTM A4876-Class 35B
6	Seal cover	Cast iron	EN 1561-GJL-250 (JL1040)	ASTM A4876-Class 35B
7	Bearing cover	Cast iron	EN 1561-GJL-250 (JL1040)	ASTM A4876-Class 35B
8	Motor support	Cast iron	EN 1561-GJL-250 (JL1040)	ASTM A4876-Class 35B
9	Bushing	Bronze	G-CuSn16	
10	Shaft sleeve for bushing	Stainless steel	EN 10088-1-X20Cr13 (1.4021)	AISI 420
11	Shaft sleeve for bushing	Stainless steel	EN 10088-1-X20Cr13 (1.4021)	AISI 420
12	Tie-rod	Carbon steel	EN ISO 898-1 8.8	F568 - Class 8.8
13	Shaft sleeve for seal	Stainless steel	EN 10088-1-X20Cr13 (1.4021)	AISI 420
14	Coupling protection	Carbon steel	EN 10025-S235JRG2 (1.0038)	A570 - Grade 36
15	Mechanical seal	Carburundum / resin-impregnated carbon / EPDM (standard version)		
16	Elastomers	EPDM (standard version)		
17	Keys	Carbon steel	EN 10083-1-C45E(1.1191)	A576 - Grade 1042
18	Plugs	Carbon steel	EN ISO 898-1 5.8	A568 - Class 5.8

td_tdv-f-en_a_tm

TABLE OF MATERIALS VERSION FB

N°	NAME	MATERIAL	REFERENCE STANDARDS	
			EUROPE	USA
1	Impeller	Bronze	EN 1982-G-CuSn10-C (CC480K)	UNS C90700
2	Diffusers	Cast iron	EN 1561-GJL-250 (JL1040)	ASTM A4876-Class 35B
3	sunction body	Cast iron	EN 1561-GJL-250 (JL1040)	ASTM A4876-Class 35B
4	delivery body	Cast iron	EN 1561-GJL-250 (JL1040)	ASTM A4876-Class 35B
	delivery body PN63	Cast iron	EN 1563-GJS-400-15 (JS1072)	ASTM A536-60-40-18
5	Stage casing	Cast iron	EN 1561-GJL-250 (JL1040)	ASTM A4876-Class 35B
6	Seal cover	Cast iron	EN 1561-GJL-250 (JL1040)	ASTM A4876-Class 35B
7	Bearing cover	Cast iron	EN 1561-GJL-250 (JL1040)	ASTM A4876-Class 35B
8	Motor support	Cast iron	EN 1561-GJL-250 (JL1040)	ASTM A4876-Class 35B
9	Bushing	Bronze	G-CuSn16	
10	Shaft sleeve for bushing	Stainless steel	EN 10088-1-X20Cr13 (1.4021)	AISI 420
11	Shaft sleeve for bushing	Stainless steel	EN 10088-1-X20Cr13 (1.4021)	AISI 420
12	Tie-rod	Carbon steel	EN ISO 898-1 8.8	F568 - Class 8.8
13	Shaft sleeve for seal	Stainless steel	EN 10088-1-X20Cr13 (1.4021)	AISI 420
14	Coupling protection	Carbon steel	EN 10025-S235JRG2 (1.0038)	A570 - Grade 36
15	Mechanical seal	Carburundum / resin-impregnated carbon / EPDM (standard version)		
16	Elastomers	EPDM (standard version)		
17	Keys	Carbon steel	EN 10083-1-C45E(1.1191)	A576 - Grade 1042
18	Plugs	Carbon steel	EN ISO 898-1 5.8	A568 - Class 5.8

td_tdv-fb-en_a_tm

TABLE OF MATERIALS VERSION N

N°	NAME	MATERIAL	REFERENCE STANDARDS	
			EUROPE	USA
1	Impeller	Stainless steel	EN 10213-4-GX5CrNiMo19-11-2 (1.4408)	ASTM CF8M (AISI316 cast)
2	Diffusers	Stainless steel	EN 10213-4-GX5CrNiMo19-11-2 (1.4408)	ASTM CF8M (AISI316 cast)
3	sunction body	Stainless steel	EN 10213-4-GX5CrNiMo19-11-2 (1.4408)	ASTM CF8M (AISI316 cast)
4	delivery body	Stainless steel	EN 10213-4-GX5CrNiMo19-11-2 (1.4408)	ASTM CF8M (AISI316 cast)
5	Stage casing	Stainless steel	EN 10213-4-GX5CrNiMo19-11-2 (1.4408)	ASTM CF8M (AISI316 cast)
6	Seal cover	Stainless steel	EN 10213-4-GX5CrNiMo19-11-2 (1.4408)	ASTM CF8M (AISI316 cast)
7	Bearing cover	Cast iron	EN 1561-GJL-250 (JL1040)	ASTM A4876-Class 35B
8	Motor support	Cast iron	EN 1561-GJL-250 (JL1040)	ASTM A4876-Class 35B
9	Bushing	Bronze	G-CuSn16	
10	Shaft sleeve for bushing	Stainless steel	EN 10088-1-X2CrNiMoN22-5-3 (1.4462)	AISI 329 LN - S31803
11	Shaft sleeve for bushing	Stainless steel	EN 10088-1-X2CrNiMoN22-5-3 (1.4462)	AISI 329 LN - S31803
12	Tie-rod	Carbon steel	EN ISO 898-1 8.8	F568 - Class 8.8
13	Shaft sleeve for seal	Stainless steel	EN 10088-1-X20Cr13 (1.4021)	AISI 420
14	Coupling protection	Carbon steel	EN 10025-S235JRG2 (1.0038)	A570 - Grade 36
15	Mechanical seal	Carburundum / resin-impregnated carbon / EPDM (standard version)		
16	Elastomers	EPDM (standard version)		
17	Keys	Stainless steel	EN 10088-2-X6CrNiMoTi17-12-1 (1.4571)	A276 - Typ 316T i
18	Plugs	Stainless steel	EN 10088-2-X6CrNiMoTi17-12-1 (1.4571)	A276 - Typ 316T i

td_tdv-n-en_a_tm

TDB-TDV SERIES MECHANICAL SEALS, ACCORDING TO EN 12756

Mechanical seal with assembly dimensions according to EN12756 (formerly DIN 24960) and ISO 3069.

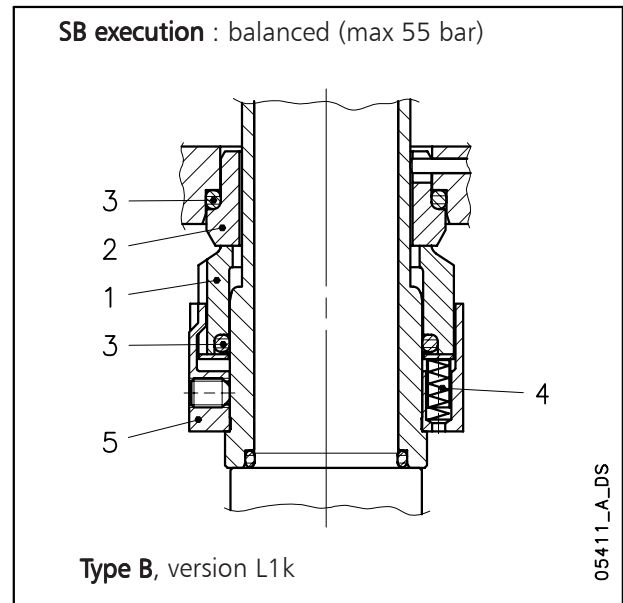
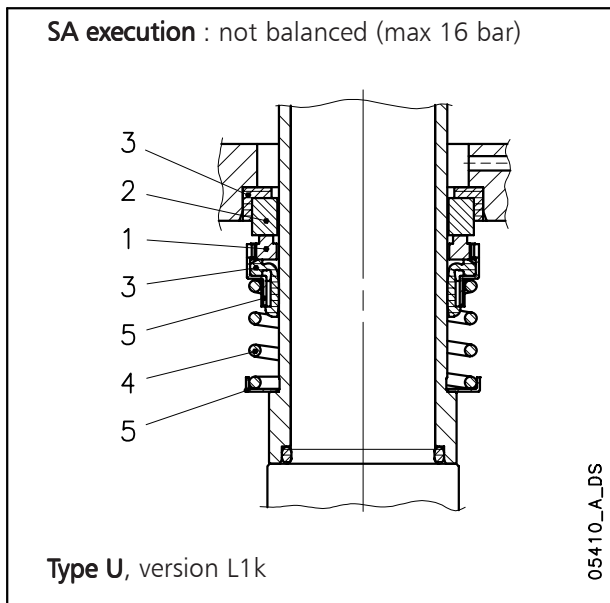

LIST OF MATERIALS

POSITION 1 - 2	POSITION 3	POSITION 4 - 5
Q ₁ : Silicon Carbide	E : EPDM	G : AISI 316
B : Resin impregnated carbon	V : FPM	

tdb-tdv_ten-mec-en_a_tm

SEAL TYPES

TYPE	POSITION				
	1 ROTATING PART	2 FIXED PART	3 ELASTOMERS	4 SPRINGS	5 OTHER COMPONENTS
STANDARD MECHANICAL SEAL					
Q ₁ B E G G	Q ₁	B	E	G	G
OTHER TYPES OF MECHANICAL SEAL (ON REQUEST)					
Q ₁ B V G G	Q ₁	B	V	G	G
Q ₁ Q ₁ V G G	Q ₁	Q ₁	V	G	G

tdb-tdv_tipi-ten-mec-en_a_tc

SEAL DIMENSIONS

PUMP TYPE	SEAL DIAMETER (mm)
TDB 22 - TDB 35	35
TDB 58 - TDB 78	43
TDB - TDV 120	53
TDB - TDV 170	
TDV 220	60
TDV 280	

tdb-tdv_dim-ten-en_a_td

MOTORS FOR TDB-TDV SERIES

- **Standard supplied IE2 three-phase surface motors $\geq 0,75$ kW are compliant with Regulation (EC) no. 640/2009 and IEC 60034-30.**
- Short-circuit squirrel-cage motor (TEFC), enclosed construction with external ventilation.
- IP55 protection.
- Class 155 (F) insulation.
- Performance according to EN 60034-1.
- Cable gland with standard passage dimensions according to EN 50262 (metric thread).
- **Three-phase** version 220-240/380-415 V 50 Hz for power up to 3 kW.
380-415/660-690 V 50 Hz for power above 3 kW.
Overload protection to be provided by the user.

TDB-TDV SERIES THREE-PHASE MOTORS AT 50 Hz, 2 POLES (up to 22 kW)

P _N kW	Efficiency η_N %																		IE	Year of manufacture
	Δ 220 V Y 380 V			Δ 230 V Y 400 V			Δ 240 V Y 415 V			Δ 380 V Y 660 V			Δ 400 V Y 690 V			Δ 415 V				
	4/4	3/4	2/4	4/4	3/4	2/4	4/4	3/4	2/4	4/4	3/4	2/4	4/4	3/4	2/4	4/4	3/4	2/4		
2,2	83,7	84,6	82,9	83,7	84,6	82,9	83,7	84,6	82,9	83,7	84,6	83,6	84,6	84,9	83,3	84,9	84,9	82,9	2	By June 2011
3	86,1	87,0	85,6	86,1	87,0	85,6	86,1	87,0	85,6	86,1	87,4	87,1	86,6	87,4	86,5	86,7	87,0	85,6		
4	86,3	86,3	86,3	86,3	86,3	86,3	86,3	86,3	86,3	86,3	86,3	86,3	86,3	86,3	86,3	86,3	86,3	86,3		
5,5	87,6	87,6	87,6	87,6	87,6	87,6	87,6	87,6	87,6	87,6	87,6	87,6	87,6	87,6	87,6	87,6	87,6	87,6		
7,5	88,6	88,1	88,1	88,6	88,1	88,1	88,6	88,1	88,1	88,6	88,1	88,1	88,6	88,1	88,1	88,6	88,1	88,1		
11	90,3	91,1	90,3	90,3	91,1	90,3	90,3	91,1	90,3	90,3	91,1	90,3	90,8	91,1	90,3	91,0	91,1	90,3		
15	90,3	90,3	90,3	90,3	90,3	90,3	90,3	90,3	90,3	90,3	90,3	90,3	90,3	90,3	90,3	90,3	90,3	90,3		
18,5	91,2	91,2	91,2	91,2	91,2	91,2	91,2	91,2	91,2	91,2	91,2	91,2	91,2	91,2	91,2	91,2	91,2	91,2		
22	91,3	91,3	91,3	91,3	91,3	91,3	91,3	91,3	91,3	91,3	91,3	91,3	91,3	91,3	91,3	91,3	91,3	91,3		

P _N kW	Manufacturer		IEC SIZE*	Construction Design	N. of Poles	f _N Hz	Data for 400 V / 50 Hz Voltage				
	Lowara srl Unipersonale Reg. No. 341820260 Montecchio Maggiore Vicenza - Italia						cos ϕ	I _s / I _N	T _N Nm	T _s /T _N	T _m /T _N
	Model										
2,2	PLM90B14/322		90	V1/B5	2	50	0,80	8,63	7,25	3,74	3,71
3	PLM100RB14/330		100R				0,82	8,39	9,96	3,50	3,32
4	PLM112RB14/340		112R				0,85	9,52	13,13	3,04	4,40
5,5	PLM132RB5/355		132R				0,87	10,3	18,11	4,43	5,80
7,5	PLM132B5/375		132				0,87	9,21	24,5	3,26	4,55
11	PLM160RB5/3110		160R				0,87	9,72	36,0	3,46	4,56
15	PLM160B5/3150		160				0,91	8,45	48,6	2,26	3,81
18,5	PLM160B5/3185		160				0,88	9,75	59,8	2,82	4,53
22	PLM180RB5/3220		180R				0,89	9,50	71,1	2,74	4,26

P _N kW	Voltage U _N V											n _N min ⁻¹	See note.	Operating conditions **		
	Δ			Y			Δ			Y				Altitude Above Sea Level (m)	T. amb min/max °C	ATEX
	220 V	230 V	240 V	380 V	400 V	415 V	380 V	400 V	415 V	660 V	690 V					
2,2	8,05	8,04	8,09	4,65	4,64	4,67	4,62	4,61	4,63	2,67	2,66	2885 ÷ 2900	≤ 1000	-15 / 40	No	
3	10,8	10,6	10,6	6,23	6,14	6,12	6,18	6,10	6,06	3,57	3,52	2850 ÷ 2885				
4	13,6	13,5	13,5	7,88	7,77	7,79	7,80	7,63	7,65	4,51	4,41	2895 ÷ 2920				
5,5	18,3	18,0	17,9	10,6	10,4	10,3	10,6	10,4	10,5	6,14	6,02	2885 ÷ 2905				
7,5	25,4	24,8	24,4	14,7	14,3	14,1	14,5	14,0	13,9	8,35	8,11	2920 ÷ 2935				
11	36,0	35,1	34,7	20,8	20,3	20,0	20,8	20,3	20,1	12,0	11,7	2910 ÷ 2925				
15	47,2	45,3	44,0	27,2	26,2	25,4	27,2	26,0	25,3	15,7	15,0	2940 ÷ 2950				
18,5	58,3	56,9	55,9	33,7	32,9	32,3	34,1	33,2	32,8	19,7	19,1	2945 ÷ 2955				
22	68,3	66,2	64,3	39,4	38,2	37,1	40,0	38,6	37,8	23,1	22,3	2945 ÷ 2955				

* R = Reduced size of motor casing as compared to shaft extension and flange.

tdb-tdv-ie2-mott22-2p50-en_a_te

Note: Observe the regulations and codes locally in force regarding sorted waste disposal.

** Operating conditions to be referred to motor only. About electric pump, refer to limits in user's manual.

TDB-TDV SERIES THREE-PHASE MOTORS AT 50 Hz, 2 POLES (from 30 to 355 kW)

P _N kW	Efficiency η_N %									IE	Year of manufacture
	Δ 380 V Y 660 V			Δ 400 V Y 690 V			Δ 415 V				
	4/4	3/4	2/4	4/4	3/4	2/4	4/4	3/4	2/4		
30	92,6	92,9	92,7	92,5	93,0	92,9	93,0	93,0	92,3	2	By June 2011
37	93,0	93,3	93,2	93,0	93,4	93,3	93,5	93,4	92,8		
45	93,2	93,5	93,4	93,3	93,6	93,6	93,8	93,6	93,1		
55	93,6	93,8	93,8	93,6	93,9	93,9	94,0	93,8	93,3		
75	94,1	94,3	93,6	93,4	94,3	94,3	94,3	94,2	93,2		
90	94,4	94,6	94,2	94,0	94,6	94,6	94,5	94,5	93,8		
110	94,8	94,9	94,5	94,3	94,9	94,9	94,9	94,8	94,1		
132	94,9	95,1	94,6	94,5	95,1	95,1	95,2	95,1	94,4		
160	95,2	95,2	94,9	94,8	95,3	95,3	95,3	95,3	94,7		
200	95,2	95,4	95,0	95,0	95,5	95,4	95,5	95,5	94,9		
250	95,3	95,5	95,1	95,1	95,6	95,5	95,6	95,6	95,0		
315	95,4	95,5	94,2	95,2	95,6	95,6	95,7	95,6	95,2		
355	95,4	95,5	95,3	95,3	95,6	95,6	95,7	95,6	95,3		

P _N kW	Manufacturer		IEC SIZE	Construction Design	N. of Poles	f _N Hz	Data for 400 V / 50 Hz Voltage				
	WEG Equipamentos Eletricos S.A. Reg. No. 07.175.725/0010-50 Jaragua do Sul - SC (Brazil)						cos ϕ	I _s / I _N	T _N Nm	Ts/T _N	Tm/T _N
	Model										
30	W22 200L2-B5 30kW		200	V1/B5	2	50	0,87	6,50	97,00	2,40	2,70
37	W22 200L2-B5 37kW		200				0,87	6,80	120,0	2,40	2,60
45	W22 225S/M2-B5 45kW		225				0,89	7,00	145,0	2,20	2,80
55	W22 250S/M2-B5 55kW		250				0,89	7,00	178,0	2,20	2,80
75	W22 280S/M2-B5 75kW		280				0,89	7,00	241,0	2,00	2,80
90	W22 280S/M2-B5 90kW		280				0,89	7,00	289,0	2,00	2,80
110	W22 315S/M2-B5 110kW		315				0,89	7,30	353,0	2,00	2,90
132	W22 315S/M2-B5 132kW		315				0,90	7,30	423,0	2,00	2,90
160	W22 315S/M2-B5 160kW		315				0,90	7,50	513,0	2,20	2,90
200	W22 315L2-B5 200kW		315				0,90	7,50	641,0	2,30	2,80
250	W22 315L2-B5 250kW		315				0,91	7,80	802,0	2,40	2,80
315	W22 355M/L2-B5 315kW		355				0,92	7,80	1008	2,10	2,60
355	W22 355M/L2-B5 355kW		355				0,91	7,90	1136	2,20	2,80

P _N kW	Voltage U _N V					n _N min ⁻¹	Observe the regulations and codes locally in force regarding sorted waste disposal.	Operating conditions **		
	Δ			Y				Altitude Above Sea Level (m)	T. amb min/max °C	ATEX
	380 V	400 V	415 V	660 V	690 V					
	I _N (A)									
30	55,90	53,60	52,20	32,18	31,07	2950 ÷ 2960	≤ 1000	-15 / 40	No	
37	68,70	65,80	64,00	39,55	38,14	2945 ÷ 2955				
45	81,50	78,00	75,80	46,92	45,22	2955 ÷ 2960				
55	99,20	95,00	92,50	57,12	55,07	2955 ÷ 2960				
75	135,00	129,00	126,00	77,73	74,78	2970 ÷ 2975				
90	161,00	154,00	151,00	92,70	89,28	2970 ÷ 2975				
110	196,00	188,00	183,00	112,85	108,99	2975 ÷ 2980				
132	232,00	223,00	217,00	133,58	129,28	2975 ÷ 2980				
160	281,00	269,00	262,00	161,79	155,94	2975 ÷ 2980				
200	351,00	336,00	324,00	202,09	194,78	2975 ÷ 2980				
250	438,00	415,00	400,00	252,18	240,58	2980 ÷ 2980				
315	545,00	517,00	498,00	313,79	299,71	2980 ÷ 2985				
355	621,00	589,00	567,00	357,55	341,45	2980 ÷ 2985				

** Operating conditions to be referred to motor only. About electric pump, refer to limits in user's manual.

tdb-tdv-ie2-mott355-2p50-en_a_te

TDB-TDV SERIES THREE-PHASE MOTORS AT 50 Hz, 4 POLES (up to 15 kW)

P _N kW	Efficiency η_N %																		IE	Year of manufacture
	Δ 220 V Y 380 V			Δ 230 V Y 400 V			Δ 240 V Y 415 V			Δ 380 V Y 660 V			Δ 400 V Y 690 V			Δ 415 V				
	4/4	3/4	2/4	4/4	3/4	2/4	4/4	3/4	2/4	4/4	3/4	2/4	4/4	3/4	2/4	4/4	3/4	2/4		
1,1	81,4	81,4	81,1	81,4	81,4	81,1	81,4	81,4	81,1	81,4	81,4	81,1	81,4	81,4	81,1	81,4	81,4	81,1	2	By June 2011
1,5	83,1	83,1	82,0	83,1	83,1	82,0	83,1	83,1	82,0	83,1	83,1	82,0	83,1	83,1	82,0	83,1	83,1	82,0		
2,2	84,7	84,7	84,7	84,7	84,7	84,7	84,7	84,7	84,7	84,7	84,7	84,7	84,7	84,7	84,7	84,7	84,7	84,7		
3	85,5	85,5	84,1	85,5	85,5	84,1	85,5	85,5	84,1	85,5	85,5	84,1	85,5	85,5	84,1	85,5	85,5	84,1		
4	86,6	86,6	86,6	86,6	86,6	86,6	86,6	86,6	86,6	86,6	86,6	86,6	86,6	86,6	86,6	86,6	86,6	86,6		
5,5	88,0	88,0	88,0	88,0	88,0	88,0	88,0	88,0	88,0	88,0	88,0	88,0	88,0	88,0	88,0	88,0	88,0	88,0		
7,5	88,7	88,7	88,7	88,7	88,7	88,7	88,7	88,7	88,7	88,7	88,7	88,7	88,7	88,7	88,7	88,7	88,7	88,7		
11	89,8	89,8	89,8	89,8	89,8	89,8	89,8	89,8	89,8	89,8	89,8	89,8	89,8	89,8	89,8	89,8	89,8	89,8		
15	90,6	90,6	89,9	90,6	90,6	89,9	90,6	90,6	89,9	90,6	90,6	89,9	90,6	90,6	89,9	90,6	90,6	89,9		

P _N kW	Manufacturer		IEC SIZE	Construction Design	N. of Poles	f _N Hz	Data for 400 V / 50 Hz Voltage				
	Lowara srl Unipersonale Reg. No. 341820260 Montecchio Maggiore (Vicenza) - Italia						cos ϕ	I _s / I _N	T _N Nm	T _s /T _N	T _m /T _N
	Model										
1,1	PLM490B14/311		90	V1/B5	4	50	0,72	6,34	7,27	2,80	3,43
1,5	PLM490B14/315		90				0,67	6,79	9,88	3,33	3,67
2,2	PLM4100B14/322		100				0,77	7,50	14,4	2,71	3,97
3	PLM4100B14/330		100				0,73	7,84	19,6	2,96	4,09
4	PLM4112B14/340		112				0,78	7,91	26,3	2,86	3,94
5,5	PLM4132B5/355		132				0,78	7,89	35,9	2,79	3,47
7,5	PLM4132B5/375		132				0,78	7,71	49,1	2,75	3,63
11	PLM4160B5/3110		160				0,83	6,94	71,6	2,34	3,02
15	PLM4160B5/3150		160				0,78	7,63	97,2	2,61	3,63

P _N kW	Voltage U _N V											n _N min ⁻¹	Operating conditions **			
	Δ			Y			Δ			Y			See note:	Altitude Above Sea Level (m)	T. amb min/max °C	ATEX
	220 V	230 V	240 V	380 V	400 V	415 V	380 V	400 V	415 V	660 V	690 V					
	I _N (A)															
1,1	4,64	4,61	4,61	2,68	2,66	2,66	2,66	2,64	2,64	1,54	1,53	1435 ÷ 1445	≤ 1000	-15 / 40	No	
1,5	6,50	6,51	6,62	3,75	3,76	3,82	3,74	3,75	3,80	2,16	2,16	1440 ÷ 1450				
2,2	8,49	8,31	8,24	4,90	4,80	4,76	4,87	4,78	4,72	2,81	2,76	1445 ÷ 1455				
3	12,0	11,9	12,0	6,91	6,89	6,94	6,88	6,86	6,90	3,97	3,96	1455 ÷ 1465				
4	15,5	15,3	15,2	8,93	8,82	8,78	8,80	8,64	8,60	5,08	4,99	1445 ÷ 1455				
5,5	20,4	19,9	19,6	11,8	11,5	11,3	11,9	11,5	11,5	6,85	6,66	1455 ÷ 1465				
7,5	27,4	26,8	26,4	15,8	15,5	15,2	15,9	15,6	15,4	9,20	8,98	1450 ÷ 1460				
11	38,3	37,9	37,9	22,1	21,9	21,9	21,8	21,2	21,1	12,6	12,3	1465 ÷ 1470				
15	52,2	52,1	52,8	30,1	30,1	30,5	30,4	30,4	31,0	17,6	17,6	1470 ÷ 1475				

Note: Observe the regulations and codes locally in force regarding sorted waste disposal.

tdb-tdv-ie2-mott15-4p50-en_a_te

** Operating conditions to be referred to motor only. About electric pump, refer to limits in user's manual.

TDB-TDV SERIES THREE-PHASE MOTORS AT 50 Hz, 4 POLES (from 18,5 to 90 kW)

P _N kW	Efficiency η_N %									IE	Year of manufacture
	Δ 380 V Y 660 V			Δ 400 V Y 690 V			Δ 415 V				
	4/4	3/4	2/4	4/4	3/4	2/4	4/4	3/4	2/4		
18,5	91,2	91,7	91,8	91,5	91,8	91,6	91,7	91,7	91,1	2	By June 2011
22	91,9	92,4	92,5	92,2	92,5	92,3	92,4	92,4	91,8		
30	92,4	92,9	92,9	92,6	93,0	92,8	92,9	92,9	92,3		
37	92,8	93,1	93,2	93,0	93,2	93,2	93,3	93,1	92,7		
45	93,2	93,6	93,5	93,2	93,7	93,6	93,7	93,6	92,9		
55	93,7	93,8	93,8	93,6	93,9	94,0	94,1	93,9	93,3		
75	94,2	94,5	94,2	93,8	94,4	94,4	94,4	94,3	93,5		
90	94,5	94,7	94,4	94,1	94,7	94,7	94,7	94,6	93,8		

P _N kW	Manufacturer		IEC SIZE	Construction Design	N. of Poles	f _N Hz	Data for 400 V / 50 Hz Voltage				
	Lowara srl Unipersonale Reg. No. 341820260 Montecchio Maggiore (Vicenza) - Italia						cos ϕ	I _s / I _N	T _N Nm	T _s /T _N	T _m /T _N
	Model										
18,5	W22 180M4-B5 18,5kW		180	V1/B5	4	50	0,83	6,60	121,0	2,40	2,80
22	W22 180L4-B5 22kW		180				0,85	6,80	143,0	2,60	2,90
30	W22 200L4-B5 30kW		200				0,83	6,30	195,0	2,20	2,60
37	W22 225S/M4-B5 37kW		225				0,86	6,60	240,0	2,20	2,70
45	W22 225S/M4-B5 45kW		225				0,86	6,80	292,0	2,40	2,70
55	W22 250S/M4-B5 55kW		250				0,87	6,40	356,0	2,20	2,70
75	W22 280S/M4-B5 75kW		280				0,86	7,20	483,0	2,00	2,70
90	W22 280S/M4-B5 90kW		280				0,87	7,20	579,0	2,10	2,70

P _N kW	Voltage U _N V					n _N min ⁻¹	Operating conditions **			
	Δ			Y			See note.	Altitude Above Sea Level (m)	T. amb min/max °C	ATEX
	380 V	400 V	415 V	660 V	690 V					
	I _N (A)									
18,5	36,30	35,10	34,70	20,90	20,35	1460 ÷ 1470	≤ 1000	-15 / 40	No	
22	41,80	40,50	39,90	24,70	23,48	1460 ÷ 1465				
30	58,00	56,20	55,50	33,39	32,58	1465 ÷ 1470				
37	69,60	66,60	64,90	40,07	38,61	1470 ÷ 1475				
45	83,40	80,70	79,50	48,02	46,78	1470 ÷ 1475				
55	101,0	97,10	94,60	58,15	56,29	1470 ÷ 1475				
75	139,0	133,0	130,0	80,03	77,10	1480 ÷ 1485				
90	164,0	158,0	154,0	94,42	91,59	1480 ÷ 1485				

Note: Observe the regulations and codes locally in force regarding sorted waste disposal.

tdb-tdv-ie2-mott90-4p50-en_a_te

** Operating conditions to be referred to motor only. About electric pump, refer to limits in user's manual.

MOTOR NOISE

The tables show the mean sound pressure (Lp) measured as per Curve A (Standard ISO 1680).
 Noise values were measured with the 50 Hz motor running idle with a tolerance of 3 dB (A).

TDB-TDV SERIES MOTORS 50 Hz, 2 POLES

POWER	MOTOR TYPE	NOISE
kW	IEC SIZE*	LpA dB
2,2	90	<70
3	100R	<70
4	112R	<70
5,5	132R	<70
7,5	132	71
11	160R	73
15	160L	71
18,5	160L	73
22	180R	70
30	200L	72
37	200L	72
45	225S/M	75
55	250S/M	75
75	280S/M	77
90	280S/M	77
110	315S/M	77
132	315S/M	77
160	315S/M	77
200	315L	78
250	315L	78
315	355M/L	80
355	355M/L	80

*R=Reduced motor casing size with respect to shaft extension and related flange.

TDB4-TDV4 SERIES MOTORS 50 Hz, 4 POLES

POWER	MOTOR TYPE	NOISE
kW	IEC SIZE	LpA dB
1,1	90	<70
1,5	90	<70
2,2	100M	<70
3	100L	<70
4	112	<70
5,5	132M	<70
7,5	132M	<70
11	160L	<70
15	160L	<70
18,5	180M	<70
22	180L	<70
30	200L	<70
37	225S/M	<70
45	225S/M	<70
55	250S/M	<70
75	280S/M	<70
90	280S/M	<70

td_tdb-tdv_mott-en_c_tr

AVAILABLE VOLTAGES MOTORS FOR TDB-TDV SERIES (up to 22 kW)

P _N kW	THREE-PHASE - 2 POLES																	
	50 Hz								60 Hz								50/60 Hz	
	3 x 220-230-240/380-400-415	3 x 380-400-415/660-690	3 x 200-208/346-360	3 x 255-265/440-460	3 x 290-300/500-525	3 x 440-460/-	3 x 500-525/-	3 x 220-230/380-400	3 x 255-265-277/440-460-480	3 x 380-400/660-690	3 x 440-460-480/-	3 x 110-115/190-200	3 x 200-208/346-360	3 x 330-346/575-600	3 x 575/-	3 x 230/400 50 Hz	3 x 265/460 60 Hz	3 x 400/690 50 Hz
2,2	s	o	o	o	o	o	o	s	o	o	o	o	o	o	o	o	o	o
3	s	o	o	o	o	o	o	s	o	o	o	o	o	o	o	o	o	o
4	o	s	o	o	o	o	o	s	o	o	o	o	o	o	o	o	o	o
5,5	o	s	o	o	o	o	o	s	o	o	o	o	o	o	o	o	o	o
7,5	o	s	o	o	o	o	o	s	o	o	o	o	o	o	o	o	o	o
11	o	s	o	o	o	o	o	s	o	o	o	o	o	o	o	o	o	o
15	o	s	o	o	o	o	o	s	o	o	o	o	o	o	o	o	o	o
18,5	o	s	o	o	o	o	o	s	o	o	o	o	o	o	o	o	o	o
22	o	s	o	o	o	o	o	s	o	o	o	o	o	o	o	o	o	o

s = Standard voltage

o = Optional voltage

- = Not available

tdb-tdv-volt-low-a-en_a_te

MOTORS FOR TDB-TDV SERIES (≥ 30 kW)

PN kW	THREE-PHASE - 2 POLES																			
	50 Hz								60 Hz								50/60 Hz			
	3 x 220-230-240/380-400-415	3 x 380-400-415/660-690	3 x 110/190	3 x 200-208/346-360	3 x 255-265/440-460	3 x 290-300/500-525	3 x 440-460/-	3 x 500-525/-	3 x 230/380	3 x 380-400/660-690	3 x 440-480/-	3 x 440-460/-	3 x 110-115/190-200	3 x 200-208/346-360	3 x 255-265-277/440-460-480	3 x 330-346/575-600	3 x 575/-	3 x 230/400 50 Hz	3 x 265/460 60 Hz	3 x 400/690 50 Hz
30	o	s	o	o	o	o	o	o	s	o	o	o	o	o	o	o	o	o	o	o
37	o	s	o	o	o	o	o	o	s	o	o	o	o	o	o	o	o	o	o	o
45	o	s	o	o	o	o	o	o	s	o	o	o	o	o	o	o	o	o	o	o
55	o	s	o	o	o	o	o	o	s	o	o	o	o	o	o	o	o	o	o	o
75	o	s	o	o	o	o	o	o	s	o	o	o	o	o	o	o	o	o	o	o
90	o	s	-	o	o	o	o	o	s	o	o	o	-	o	o	o	o	o	o	o
110	o	s	-	o	o	o	o	o	s	o	o	o	-	o	o	o	o	o	o	o
132	o	s	-	o	o	o	o	o	s	o	o	o	-	o	o	o	o	o	o	o
160	o	s	-	o	o	o	o	o	s	o	o	o	-	o	o	o	o	o	o	o
200	o	s	-	o	o	o	o	o	s	o	o	o	-	o	o	o	o	o	o	o
250	o	s	-	o	o	o	o	o	s	o	o	o	-	o	o	o	o	o	o	o
315	o	s	-	o	o	o	o	o	s	o	o	o	-	o	o	o	o	o	o	o
355	o	s	-	o	o	o	o	o	s	o	o	o	-	o	o	o	o	o	o	o

s = Standard voltage

o = Optional voltage

- = Not available

td-volt-weg-en_a_te

**TDB-TDV SERIES
HYDRAULIC PERFORMANCE RANGE AT 50 Hz, 2 POLES**

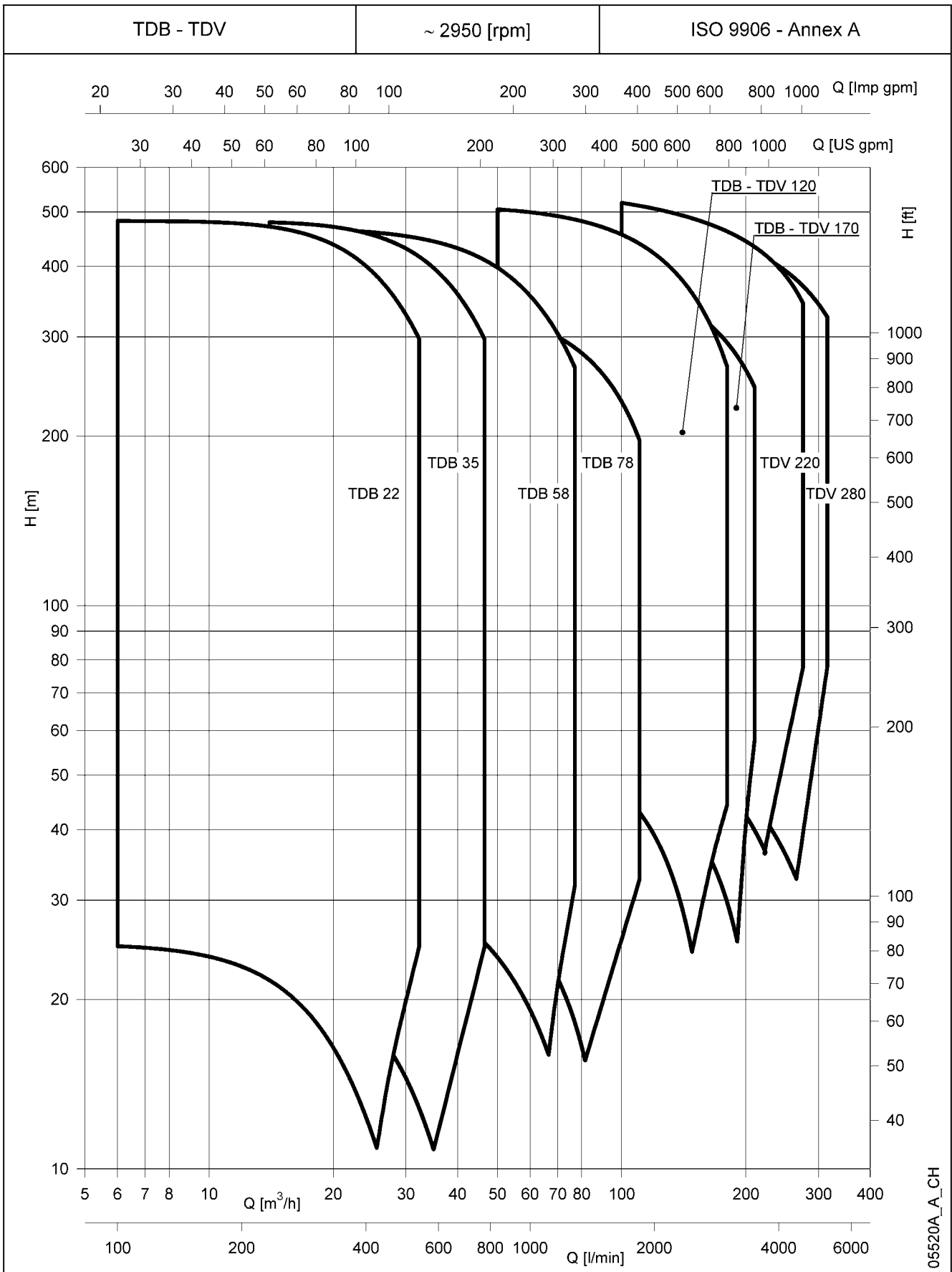

05520A_A_CH

These performances are valid for liquids with density $\rho = 1,0 \text{ Kg/dm}^3$ and kinematic viscosity $\nu = 1 \text{ mm}^2/\text{sec}$.

TDB22 SERIES HYDRAULIC PERFORMANCE TABLE AT 50 Hz, 2 POLES

PUMP TYPE	RATED POWER		Q = DELIVERY										
	kW	HP	V _{min} 0	100	166,7	250	300	350	400	441,7	500,0	533,3	583,3
			m ³ /h 0	6	10	15	18	21	24	26,5	30	32	35
H = TOTAL HEAD METRES COLUMN OF WATER													
TDB22 01/1C	2,2	3	24,9	24,9	23,8	20,9	18,4	15,4	12,4				
TDB22 01/1B	3	4	32,8	32,8	32,1	30,0	28,1	25,6	22,7	20,0	16,1		
TDB22 01/1A	4	5	40,3	40,1	40,0	38,9	37,6	35,8	33,4	31,1	27,4	25,2	21,8
TDB22 02/2C	4	5	49,9	49,7	47,6	41,8	36,7	30,8					
TDB22 02/1B1C	5,5	7,4	57,7	57,6	55,9	50,9	46,4	41,0	35,0	30,0			
TDB22 02/2B	7,5	10	65,5	65,6	64,2	60,0	56,1	51,2	45,3	40,0			
TDB22 02/1A1B	7,5	10	73,1	72,9	72,1	69,0	65,7	61,4	56,1	51,1	43,5	39,0	
TDB22 02/2A	11	15	80,6	80,3	80,0	77,9	75,3	71,6	66,8	62,1	54,8	50,3	43,7
TDB22 03/2B1C	7,5	10	90,5	90,4	88,0	81,0	74,5	66,6	57,7	50,0			
TDB22 03/3B	11	15	98,3	98,3	96,3	90,1	84,2	76,7	68,0	60,0			
TDB22 03/1A2B	11	15	105,8	105,7	104,2	99,0	93,8	87,0	78,7	71,1	59,5		
TDB22 03/2A1B	15	20	113,4	113,1	112,1	107,9	103,3	97,2	89,5	82,1	70,8	64,2	
TDB22 03/3A	15	20	120,9	120,4	119,9	116,8	112,9	107,4	100,2	93,2	82,1	75,5	65,5
TDB22 04/4B	15	20	131,1	131,1	128,4	120,1	112,2	102,3	90,7	80,0			
TDB22 04/1A3B	15	20	138,6	138,5	136,3	129,0	121,8	112,5	101,4	91,1			
TDB22 04/2A2B	15	20	146,2	145,8	144,2	137,9	131,4	122,8	112,2	102,1	86,9		
TDB22 04/3A1B	15	20	153,7	153,2	152,0	146,8	141,0	133,0	122,9	113,2	98,2	89,3	
TDB22 04/4A	18,5	25	161,2	160,5	159,9	155,7	150,6	143,2	133,7	124,3	109,5	100,6	
TDB22 05/1A4B	15	20	171,4	171,3	168,4	159,0	149,9	138,1	124,1	111,1			
TDB22 05/2A3B	18,5	25	178,9	178,6	176,3	167,9	159,5	148,3	134,8	122,1			
TDB22 05/3A2B	18,5	25	186,5	186,0	184,1	176,8	169,0	158,6	145,6	133,2	114,3		
TDB22 05/4A1B	22	30	194,0	193,3	192,0	185,8	178,6	168,8	156,3	144,3	125,6	114,5	
TDB22 05/5A	22	30	201,6	200,7	199,9	194,7	188,2	179,0	167,1	155,3	136,9	125,8	
TDB22 06/2A4B	22	30	211,7	211,4	208,4	198,0	187,5	173,9	157,5	142,1			
TDB22 06/3A3B	22	30	219,2	218,8	216,2	206,9	197,1	184,1	168,2	153,2			
TDB22 06/4A2B	22	30	226,8	226,1	224,1	215,8	206,7	194,3	179,0	164,3	141,7		
TDB22 06/5A1B	30	40	234,3	233,5	232,0	224,7	216,3	204,6	189,7	175,3	153,0	139,6	
TDB22 06/6A	30	40	241,9	240,8	239,9	233,6	225,9	214,8	200,5	186,4	164,3	150,9	
TDB22 07/3A4B	30	40	252,0	251,5	248,3	236,9	225,2	209,7	190,9	173,2			
TDB22 07/4A3B	30	40	259,6	258,9	256,2	245,8	234,7	219,9	201,7	184,3			
TDB22 07/5A2B	30	40	267,1	266,2	264,1	254,7	244,3	230,1	212,4	195,3	169,1		
TDB22 07/6A1B	30	40	274,6	273,6	272,0	263,6	253,9	240,4	223,2	206,4	180,3	164,8	
TDB22 07/7A	30	40	282,2	280,9	279,9	272,5	263,5	250,6	233,9	217,5	191,6	176,1	
TDB22 08/4A4B	30	40	292,3	291,7	288,3	275,8	262,8	245,5	224,3	204,3			
TDB22 08/5A3B	30	40	299,9	299,0	296,2	284,7	272,4	255,7	235,1	215,3			
TDB22 08/6A2B	30	40	307,4	306,4	304,1	293,7	282,0	265,9	245,8	226,4	196,4		
TDB22 08/7A1B	37	50	315,0	313,7	312,0	302,6	291,6	276,2	256,6	237,5	207,7		
TDB22 08/8A	37	50	322,5	321,1	319,9	311,5	301,1	286,4	267,3	248,5	219,0	201,2	
TDB22 09/5A4B	37	50	332,6	331,8	328,3	314,8	300,4	281,3	257,7	235,3			
TDB22 09/6A3B	37	50	340,2	339,2	336,2	323,7	310,0	291,5	268,5	246,4			
TDB22 09/7A2B	37	50	347,7	346,5	344,1	332,6	319,6	301,7	279,2	257,5	223,8		
TDB22 09/8A1B	37	50	355,3	353,9	352,0	341,5	329,2	312,0	290,0	268,5	235,1		
TDB22 09/9A	37	50	362,8	361,2	359,8	350,4	338,8	322,2	300,7	279,6	246,4	226,4	
TDB22 10/6A4B	37	50	372,9	371,9	368,3	353,7	338,1	317,1	291,2	266,4			
TDB22 10/7A3B	37	50	380,5	379,3	376,2	362,6	347,7	327,3	301,9	277,5			
TDB22 10/8A2B	37	50	388,0	386,6	384,1	371,5	357,3	337,5	312,6	288,5	251,2		
TDB22 10/9A1B	45	60	395,6	394,0	391,9	380,4	366,8	347,8	323,4	299,6	262,5		
TDB22 10/10A	45	60	403,1	401,3	399,8	389,3	376,4	358,0	334,1	310,7	273,8	251,5	
TDB22 11/7A4B	45	60	413,3	412,1	408,3	392,6	375,7	352,9	324,6	297,5			
TDB22 11/8A3B	45	60	420,8	419,4	416,2	401,5	385,3	363,1	335,3	308,5			
TDB22 11/9A2B	45	60	428,3	426,8	424,0	410,5	394,9	373,3	346,1	319,6	278,6		
TDB22 11/10A1B	45	60	435,9	434,1	431,9	419,4	404,5	383,6	356,8	330,7	289,9		
TDB22 11/11A	45	60	443,4	441,5	439,8	428,3	414,1	393,8	367,6	341,7	301,2	276,7	
TDB22 12/8A4B	45	60	453,6	452,2	448,3	431,6	413,4	388,7	358,0	328,5			
TDB22 12/9A3B	45	60	461,1	459,6	456,1	440,5	423,0	398,9	368,7	339,6			
TDB22 12/10A2B	45	60	468,7	466,9	464,0	449,4	432,5	409,1	379,5	350,7	305,9		
TDB22 12/11A1B	55	74	476,2	474,3	471,9	458,3	442,1	419,3	390,2	361,7	317,2		
TDB22 12/12A	55	74	483,7	481,6	479,8	467,2	451,7	429,6	401,0	372,8	328,5	301,8	

TDB35 SERIES HYDRAULIC PERFORMANCE TABLE AT 50 Hz, 2 POLES

PUMP TYPE	RATED POWER		Q = DELIVERY										
			l/min 0	233,3	300	333,3	416,7	500	583,3	666,7	750,0	833,3	900
	kW	HP	m ³ /h 0	14	18	20	25	30	35	40	45	50	54
H = TOTAL HEAD METRES COLUMN OF WATER													
TDB35 01/1C	3	4	22,6	22,0	21,1	20,3	17,8	14,5	10,8				
TDB35 01/1B	4	5	30,4	30,3	29,7	29,2	27,3	24,5	21,0	17,0			
TDB35 01/1A	5,5	7	39,8	39,9	39,5	39,2	37,9	35,9	33,1	29,8	26,0	21,9	18,8
TDB35 02/2B	7,5	10	60,8	60,5	59,3	58,3	54,6	49,0	41,9	34,0			
TDB35 02/1A1B	11	14,8	70,3	70,2	69,2	68,4	65,2	60,4	54,1	46,8	39,1		
TDB35 02/2A	11	15	79,7	79,9	79,1	78,4	75,8	71,8	66,3	59,6	52,0	43,9	37,5
TDB35 03/3B	11	15	91,3	90,8	89,0	87,5	81,9	73,5	62,9	51,0			
TDB35 03/1A2B	15	20	100,7	100,5	98,9	97,6	92,5	84,9	75,1	63,8	52,1		
TDB35 03/2A1B	15	20	110,1	110,1	108,8	107,6	103,1	96,3	87,3	76,6	65,0	53,7	
TDB35 03/3A	18,5	25	119,5	119,8	118,6	117,6	113,7	107,6	99,4	89,4	77,9	65,8	56,3
TDB35 04/1A3B	18,5	25	131,1	130,7	128,5	126,7	119,8	109,4	96,1	80,8			
TDB35 04/2A2B	18,5	25	140,5	140,4	138,4	136,8	130,4	120,8	108,2	93,6			
TDB35 04/3A1B	22	30	150,0	150,1	148,3	146,8	141,0	132,1	120,4	106,4	91,0		
TDB35 04/4A	22	30	159,4	159,7	158,2	156,8	151,6	143,5	132,6	119,2	103,9	87,8	
TDB35 05/2A3B	22	30	171,0	170,7	168,1	165,9	157,7	145,3	129,2	110,6			
TDB35 05/3A2B	30	40	180,4	180,3	178,0	176,0	168,3	156,7	141,4	123,4	104,1		
TDB35 05/4A1B	30	40	189,8	190,0	187,8	186,0	178,9	168,0	153,6	136,2	117,0		
TDB35 05/5A	30	40	199,2	199,7	197,7	196,0	189,5	179,4	165,7	149,0	129,9	109,7	
TDB35 06/3A3B	30	40	210,8	210,6	207,6	205,1	195,6	181,2	162,4	140,4			
TDB35 06/4A2B	30	40	220,2	220,3	217,5	215,2	206,2	192,5	174,5	153,2	130,1		
TDB35 06/5A1B	30	40	229,7	229,9	227,4	225,2	216,8	203,9	186,7	166,0	143,0		
TDB35 06/6A	37	50	239,1	239,6	237,3	235,3	227,4	215,3	198,9	178,8	155,9		
TDB35 07/4A3B	37	50	250,7	250,5	247,2	244,4	233,5	217,0	195,5	170,2			
TDB35 07/5A2B	37	50	260,1	260,2	257,1	254,4	244,1	228,4	207,7	183,0	156,0		
TDB35 07/6A1B	37	50	269,5	269,9	266,9	264,4	254,7	239,8	219,9	195,8	168,9		
TDB35 07/7A	37	50	278,9	279,6	276,8	274,5	265,3	251,2	232,0	208,5	181,8		
TDB35 08/5A3B	37	50	290,5	290,5	286,7	283,6	271,4	252,9	228,7	200,0			
TDB35 08/6A2B	37	50	299,9	300,2	296,6	293,6	282,0	264,3	240,8	212,8			
TDB35 08/7A1B	45	60	309,4	309,8	306,5	303,6	292,6	275,7	253,0	225,6	194,9		
TDB35 08/8A	45	60	318,8	319,5	316,4	313,7	303,2	287,0	265,2	238,3	207,8		
TDB35 09/6A3B	45	60	330,4	330,4	326,3	322,8	309,3	288,8	261,8	229,8			
TDB35 09/7A2B	45	60	339,8	340,1	336,1	332,8	319,9	300,2	274,0	242,6			
TDB35 09/8A1B	45	60	349,2	349,8	346,0	342,8	330,5	311,6	286,2	255,3	220,9		
TDB35 09/9A	55	74	358,6	359,4	355,9	352,9	341,1	322,9	298,3	268,1	233,8		
TDB35 10/7A3B	55	74	370,2	370,4	365,8	362,0	347,2	324,7	295,0	259,6			
TDB35 10/8A2B	55	74	379,6	380,0	375,7	372,0	357,8	336,1	307,1	272,3			
TDB35 10/9A1B	55	74	389,1	389,7	385,6	382,1	368,4	347,4	319,3	285,1	246,9		
TDB35 10/10A	55	74	398,5	399,4	395,4	392,1	379,0	358,8	331,5	297,9	259,8		
TDB35 11/8A3B	55	74	410,1	410,3	405,4	401,2	385,1	360,6	328,1	289,3			
TDB35 11/9A2B	55	74	419,5	420,0	415,2	411,2	395,7	371,9	340,3	302,1			
TDB35 11/10A1B	55	74	428,9	429,6	425,1	421,3	406,3	383,3	352,5	314,9	272,8		
TDB35 11/11A	75	101	438,3	439,3	435,0	431,3	416,9	394,7	364,6	327,7	285,7		
TDB35 12/9A3B	55	74	449,9	450,2	444,9	440,4	423,0	396,4	361,3	319,1			
TDB35 12/10A2B	75	101	459,3	459,9	454,8	450,4	433,6	407,8	373,4	331,9			
TDB35 12/11A1B	75	101	468,8	469,6	464,7	460,5	444,2	419,2	385,6	344,7	298,8		
TDB35 12/12A	75	101	478,2	479,2	474,5	470,5	454,8	430,6	397,8	357,5	311,7		

Performances in compliance with ISO 9906 - Annex A.

tdb35-2p50-en_a_th

TDB58 SERIES HYDRAULIC PERFORMANCE TABLE AT 50 Hz, 2 POLES

PUMP TYPE	RATED POWER		Q = DELIVERY										
			l/min 0	383,3	583,3	750	916,7	1000	1083,3	1166,7	1250	1333,3	1400
	kW	HP	m ³ /h 0	23	35	45	55	60	65	70	75	80	84
H = TOTAL HEAD METRES COLUMN OF WATER													
TDB58 01/1C	7,5	10	34,0	32,5	29,4	25,8	21,5	19,1	16,7				
TDB58 01/1B	7,5	10	43,4	42,5	40,0	36,9	32,7	30,3	27,7	24,9	21,9		
TDB58 01/1A	11	15	54,6	53,9	51,9	48,9	44,6	42,1	39,3	36,3	33,2	30,0	27,4
TDB58 02/2C	15	20	68,0	65,0	58,8	51,7	43,0	38,3	33,4				
TDB58 02/1B1C	15	20	77,4	75,0	69,5	62,7	54,2	49,4	44,3	39,0			
TDB58 02/2B	18,5	25	86,8	84,9	80,1	73,7	65,4	60,6	55,3	49,7	43,8		
TDB58 02/1A1B	18,5	25	97,9	96,4	91,9	85,8	77,3	72,3	66,9	61,1	55,1	48,8	
TDB58 02/2A	22	30	109,1	107,8	103,8	97,8	89,2	84,1	78,5	72,5	66,3	59,9	54,9
TDB58 03/2B1C	22	30	120,8	117,4	109,5	99,6	86,9	79,7	72,0				
TDB58 03/3B	30	40	130,1	127,4	120,1	110,6	98,1	90,9	83,0	74,6			
TDB58 03/1A2B	30	40	141,3	138,8	132,0	122,6	110,0	102,6	94,6	86,0	77,0		
TDB58 03/2A1B	30	40	152,5	150,3	143,8	134,6	122,0	114,4	106,2	97,4	88,2	78,8	
TDB58 03/3A	37	50	163,7	161,7	155,7	146,7	133,9	126,2	117,8	108,8	99,5	89,9	82,3
TDB58 04/4B	30	40	173,5	169,8	160,1	147,5	130,8	121,1	110,6				
TDB58 04/1A3B	37	50	184,7	181,3	172,0	159,5	142,7	132,9	122,2	110,8			
TDB58 04/2A2B	37	50	195,9	192,7	183,9	171,5	154,7	144,7	133,8	122,3	110,1		
TDB58 04/3A1B	45	60	207,1	204,2	195,7	183,5	166,6	156,5	145,4	133,7	121,4	108,8	
TDB58 04/4A	45	60	218,2	215,6	207,6	195,5	178,5	168,2	157,0	145,1	132,6	119,9	109,8
TDB58 05/1A4B	45	60	228,1	223,7	212,0	196,4	175,5	163,2	149,9	135,7			
TDB58 05/2A3B	45	60	239,3	235,2	223,9	208,4	187,4	175,0	161,5	147,1			
TDB58 05/3A2B	55	74	250,4	246,6	235,8	220,4	199,3	186,7	173,1	158,5	143,3		
TDB58 05/4A1B	55	74	261,6	258,1	247,6	232,4	211,2	198,5	184,7	169,9	154,5	138,8	
TDB58 05/5A	55	74	272,8	269,5	259,5	244,4	223,1	210,3	196,3	181,4	165,8	149,9	137,2
TDB58 06/2A4B	55	74	282,6	277,6	263,9	245,3	220,1	205,3	189,2	172,0			
TDB58 06/3A3B	55	74	293,8	289,1	275,8	257,3	232,0	217,0	200,8	183,4	165,2		
TDB58 06/4A2B	75	101	305,0	300,5	287,7	269,3	243,9	228,8	212,4	194,8	176,4		
TDB58 06/5A1B	75	101	316,2	312,0	299,5	281,3	255,8	240,6	224,0	206,2	187,7	168,7	
TDB58 06/6A	75	101	327,3	323,4	311,4	293,3	267,7	252,4	235,6	217,6	198,9	179,8	164,7
TDB58 07/3A4B	75	101	337,2	331,5	315,8	294,2	264,7	247,3	228,4	208,2	187,1		
TDB58 07/4A3B	75	101	348,4	343,0	327,7	306,2	276,6	259,1	240,0	219,7	198,4		
TDB58 07/5A2B	75	101	359,5	354,4	339,6	318,2	288,5	270,9	251,6	231,1	209,6	187,6	
TDB58 07/6A1B	75	101	370,7	365,9	351,4	330,2	300,4	282,6	263,2	242,5	220,8	198,7	
TDB58 07/7A	75	101	381,9	377,3	363,3	342,2	312,3	294,4	274,8	253,9	232,1	209,8	192,1
TDB58 08/4A4B	75	101	391,7	385,4	367,7	343,0	309,3	289,4	267,7	244,5			
TDB58 08/5A3B	90	121	402,9	396,9	379,6	355,1	321,2	301,2	279,3	255,9	231,5		
TDB58 08/6A2B	90	121	414,1	408,3	391,5	367,1	333,1	312,9	290,9	267,3	242,7		
TDB58 08/7A1B	90	121	425,3	419,8	403,3	379,1	345,1	324,7	302,5	278,8	254,0	228,7	
TDB58 08/8A	90	121	436,5	431,2	415,2	391,1	357,0	336,5	314,1	290,2	265,2	239,8	219,6
TDB58 09/5A4B	90	121	446,3	439,3	419,6	391,9	353,9	331,4	306,9	280,8			
TDB58 09/6A3B	90	121	457,5	450,8	431,5	403,9	365,9	343,2	318,5	292,2	264,7		
TDB58 09/7A2B	90	121	468,7	462,2	443,4	416,0	377,8	355,0	330,1	303,6	275,9		

Performances in compliance with ISO 9906 - Annex A.

tdb58-2p50-en_a_th

TDB78 SERIES HYDRAULIC PERFORMANCE TABLE AT 50 Hz, 2 POLES

PUMP TYPE	RATED POWER		Q = DELIVERY										
			l/min 0	500	833,3	1000	1166,7	1333,3	1416,7	1500	1583,3	1700	1850
	kW	HP	m ³ /h 0	30	50	60	70	80	85	90	95	102	111
H = TOTAL HEAD METRES COLUMN OF WATER													
TDB78 01/1C	7,5	10	33,8	32,5	29,0	25,9	21,8	16,5					
TDB78 01/1B	11	15	44,4	43,5	40,9	38,5	35,2	31,2	28,9	26,3	23,7		
TDB78 01/1A	15	20	59,6	57,8	54,9	52,7	50,0	46,8	44,9	42,9	40,7	37,3	32,4
TDB78 02/1B1C	18,5	25	78,2	76,1	69,9	64,4	57,0	47,7	42,3				
TDB78 02/2B	22	30	88,8	87,1	81,8	76,9	70,5	62,4	57,7	52,7			
TDB78 02/1A1B	30	40	104,0	101,4	95,7	91,2	85,3	78,0	73,8	69,3	64,4	56,9	
TDB78 02/2A	37	50	119,1	115,6	109,7	105,4	100,1	93,6	89,9	85,8	81,4	74,7	64,8
TDB78 03/3B	37	50	133,2	130,6	122,6	115,4	105,7	93,6	86,6	79,0	71,0		
TDB78 03/1A2B	37	50	148,4	144,9	136,6	129,6	120,5	109,2	102,7	95,6	88,0		
TDB78 03/2A1B	45	60	163,5	159,2	150,6	143,9	135,3	124,8	118,7	112,2	105,1	94,3	
TDB78 03/3A	55	74	178,7	173,4	164,6	158,1	150,1	140,4	134,8	128,7	122,2	112,0	97,3
TDB78 04/1A3B	55	74	192,8	188,4	177,5	168,1	155,8	140,4	131,5	122,0	111,7		
TDB78 04/2A2B	55	74	207,9	202,7	191,5	182,3	170,5	156,0	147,6	138,5	128,7	113,9	
TDB78 04/3A1B	75	101	223,1	217,0	205,4	196,6	185,3	171,6	163,7	155,1	145,8	131,6	
TDB78 04/4A	75	101	238,2	231,2	219,4	210,8	200,1	187,2	179,7	171,7	162,9	149,3	129,7
TDB78 05/2A3B	75	101	252,3	246,2	232,3	220,8	205,8	187,2	176,5	164,9	152,4		
TDB78 05/3A2B	75	101	267,5	260,5	246,3	235,0	220,6	202,7	192,5	181,4	169,5	151,2	
TDB78 05/4A1B	75	101	282,6	274,8	260,3	249,3	235,4	218,3	208,6	198,0	186,5	168,9	
TDB78 05/5A	90	121	297,8	289,1	274,3	263,5	250,2	233,9	224,7	214,6	203,6	186,7	162,1
TDB78 06/3A3B	90	121	311,9	304,1	287,2	273,5	255,8	233,9	221,4	207,8	193,1		
TDB78 06/4A2B	90	121	327,0	318,3	301,2	287,7	270,6	249,5	237,5	224,4	210,2	188,6	
TDB78 06/5A1B	90	121	342,2	332,6	315,1	302,0	285,4	265,1	253,5	240,9	227,2	206,3	

Performances in compliance with ISO 9906 - Annex A.

tdb78-2p50-en_a_th

TDB-TDV120 SERIES HYDRAULIC PERFORMANCE TABLE AT 50 Hz, 2 POLES

PUMP TYPE	RATED POWER		Q = DELIVERY											
			l/min 0	833,3	1083,3	1333,3	1666,7	2000	2333,3	2500	2666,7	2833,3	3066,7	
			m ³ /h 0	50	65	80	100	120	140	150	160	170	184	
kW		HP		H = TOTAL HEAD METRES COLUMN OF WATER										
TDB120 01/1C	22	30	56,7	55,6	54,1	51,6	46,5	39,1	29,0					
TDB120 01/1B	30	40	69,5	68,5	67,1	64,9	60,4	53,9	45,6	40,8	35,7			
TDB120 01/1A	37	50	85,3	84,3	82,6	80,3	76,0	70,3	63,1	59,0	54,4	49,6	42,1	
TDB120 02/2C	45	60	113,4	111,2	108,2	103,3	93,1	78,1	58,1					
TDB120 02/1B1C	55	74	126,2	124,1	121,2	116,5	106,9	93,0	74,7	63,8				
TDB120 02/2B	55	74	139,1	137,0	134,3	129,8	120,8	107,9	91,2	81,6	71,3			
TDB120 02/1A1B	75	101	154,8	152,7	149,7	145,2	136,4	124,2	108,7	99,8	90,1	79,8		
TDB120 02/2A	75	101	170,6	168,5	165,2	160,5	151,9	140,5	126,2	117,9	108,9	99,1	84,2	
TDB120 03/1B2C	75	101	182,9	179,7	175,3	168,2	153,4	132,1	103,7					
TDB120 03/2B1C	75	101	195,8	192,6	188,4	181,5	167,3	146,9	120,3	104,7				
TDB120 03/3B	90	121	208,6	205,4	201,4	194,8	181,2	161,8	136,8	122,5				
TDB120 03/1A2B	90	121	224,4	221,2	216,9	210,1	196,7	178,1	154,3	140,6	125,8			
TDV120 03/2A1B	110	148	240,2	237,0	232,4	225,5	212,3	194,5	171,8	158,7	144,6	129,3		
TDV120 03/3A	110	148	255,9	252,8	247,8	240,8	227,9	210,8	189,3	176,9	163,3	148,7	126,3	
TDV120 04/4B	110	148	278,1	273,9	268,5	259,7	241,5	215,7	182,4	163,3				
TDV120 04/1A3B	132	177	293,9	289,7	284,0	275,0	257,1	232,1	199,9	181,4				
TDV120 04/2A2B	132	177	309,7	305,5	299,5	290,4	272,7	248,4	217,4	199,6	180,2			
TDV120 04/3A1B	160	215	325,5	321,2	315,0	305,7	288,3	264,7	234,9	217,7	199,0	178,9		
TDV120 04/4A	160	215	341,3	337,0	330,5	321,1	303,9	281,1	252,4	235,8	217,8	198,2	168,4	
TDV120 05/1A4B	160	215	363,4	358,2	351,2	339,9	317,5	286,0	245,5	222,2				
TDV120 05/2A3B	160	215	379,2	373,9	366,6	355,3	333,1	302,3	263,0	240,4				
TDV120 05/3A2B	160	215	395,0	389,7	382,1	370,6	348,7	318,7	280,5	258,5	234,7			
TDV120 05/4A1B	200	268	410,8	405,5	397,6	386,0	364,3	335,0	298,0	276,7	253,4	228,4		
TDV120 05/5A	200	268	426,6	421,3	413,1	401,3	379,8	351,3	315,5	294,8	272,2	247,8	210,5	
TDV120 06/2A4B	200	268	448,8	442,4	433,8	420,2	393,5	356,3	308,6	281,2				
TDV120 06/3A3B	200	268	464,5	458,2	449,2	435,6	409,1	372,6	326,1	299,3	270,3			
TDV120 06/4A2B	200	268	480,3	474,0	464,7	450,9	424,6	388,9	343,6	317,5	289,1			
TDV120 06/5A1B	200	268	496,1	489,8	480,2	466,3	440,2	405,3	361,1	335,6	307,9	278,0		
TDV120 06/6A	200	268	511,9	505,5	495,7	481,6	455,8	421,6	378,6	353,8	326,7	297,4		

Performances in compliance with ISO 9906 - Annex A.

tdb-tdv120-2p50-en_a_th

TDB-TDV170 SERIES HYDRAULIC PERFORMANCE TABLE AT 50 Hz, 2 POLES

PUMP TYPE	RATED POWER		Q = DELIVERY										
			l/min 0	1250	1666,7	2000	2333,3	2666,7	3000	3333,3	3583,3	3833,3	4033,3
			m ³ /h 0	75	100	120	140	160	180	200	215	230	242
kW		HP		H = TOTAL HEAD METRES COLUMN OF WATER									
TDB170 01/1C	30	40	55,6	52,8	49,8	46,6	42,3	36,8	29,8				
TDB170 01/1B	37	50	67,8	66,1	63,8	61,0	57,1	52,2	46,2	39,1	33,2		
TDB170 01/1A	45/55	60/74	89,8	85,8	82,5	79,3	75,8	71,7	66,9	61,2	56,1	50,2	44,7
TDB170 02/2C	55	74	111,2	105,6	99,7	93,2	84,6	73,6	59,5				
TDB170 02/1B1C	55	74	123,4	118,9	113,7	107,5	99,4	89,0	75,9				
TDB170 02/2B	75	101	135,6	132,3	127,6	121,9	114,2	104,4	92,4	78,3	66,3		
TDB170 02/1A1B	90	121	157,6	151,9	146,3	140,3	132,9	123,8	113,1	100,3	89,3	76,8	
TDV170 02/2A	110	148	179,5	171,6	164,9	158,7	151,5	143,3	133,8	122,3	112,2	100,3	89,4
TDV170 03/2B1C	110	148	191,2	185,1	177,5	168,5	156,5	141,1	122,1	99,1			
TDV170 03/3B	110	148	203,3	198,4	191,5	182,9	171,3	156,5	138,5	117,4	99,5		
TDV170 03/1A2B	110	148	225,3	218,1	210,1	201,2	190,0	176,0	159,2	139,4	122,4		
TDV170 03/2A1B	132	177	247,3	237,7	228,8	219,6	208,6	195,5	179,9	161,5	145,3	127,0	
TDV170 03/3A	160	215	269,3	257,4	247,4	238,0	227,3	215,0	200,6	183,5	168,3	150,5	134,1
TDV170 04/1A3B	160	215	293,1	284,2	273,9	262,2	247,1	228,2	205,4	178,5	155,6		
TDV170 04/2A2B	160	215	315,1	303,9	292,6	280,6	265,7	247,7	226,1	200,6	178,5		
TDV170 04/3A1B	200	268	337,1	323,5	311,2	299,0	284,4	267,2	246,8	222,6	201,4	177,2	
TDV170 04/4A	200	268	359,1	343,2	329,9	317,3	303,1	286,7	267,5	244,7	224,4	200,6	178,7
TDV170 05/2A3B	200	268	382,9	370,0	356,4	341,5	322,8	299,9	272,3	239,7			
TDV170 05/3A2B	200	268	404,9	389,7	375,1	359,9	341,5	319,4	293,0	261,7			

Performances in compliance with ISO 9906 - Annex A.

tdb-tdv170-2p50-en_a_th

TDV220 SERIES HYDRAULIC PERFORMANCE TABLE AT 50 Hz, 2 POLES

PUMP TYPE	RATED POWER		Q = DELIVERY											
			l/min 0	1666,7	2000	2333,3	2666,7	3000	3333,3	3716,7	4166,7	4633,3	5000	
			m ³ /h 0	100	120	140	160	180	200	223	250	278	300	
kW		HP		H = TOTAL HEAD METRES COLUMN OF WATER										
TDV220 01/1D	45	60	66,5	61,0	58,2	55,0	51,2	47,0	42,4	36,5				
TDV220 01/1C	55	74	79,3	74,5	72,1	69,3	66,1	62,4	58,2	52,7	45,1			
TDV220 01/1B	75	101	94,9	90,4	88,1	85,6	82,6	79,3	75,6	70,6	63,6	54,5		
TDV220 01/1A	90	121	120,0	112,8	110,1	107,3	104,3	101,0	97,4	92,7	85,8	76,6	67,4	
TDV220 02/1C1D	90	121	145,8	135,5	130,4	124,3	117,3	109,4	100,6					
TDV220 02/2C	90	121	158,6	149,0	144,3	138,7	132,2	124,8	116,4					
TDV220 02/1B1C	110	148	174,2	164,9	160,3	154,9	148,7	141,7	133,8	123,3				
TDV220 02/2B	132	177	189,8	180,8	176,3	171,1	165,2	158,6	151,2	141,2	127,1			
TDV220 02/1A1B	160	215	214,9	203,2	198,3	192,9	186,9	180,4	173,0	163,3	149,4	131,1		
TDV220 02/2A	160	215	239,9	225,6	220,3	214,6	208,6	202,1	194,9	185,3	171,6	153,3	134,7	
TDV220 03/1B2C	160	215	253,5	239,4	232,4	224,2	214,8	204,1	192,0	175,9				
TDV220 03/2B1C	160	215	269,1	255,3	248,4	240,5	231,4	221,1	209,4	193,9				
TDV220 03/3B	200	268	284,7	271,2	264,4	256,7	247,9	238,0	226,8	211,8	190,7			
TDV220 03/1A2B	200	268	309,8	293,6	286,4	278,4	269,5	259,7	248,6	233,9	212,9	185,5		
TDV220 03/2A1B	250	335	334,8	316,0	308,4	300,2	291,2	281,4	270,5	255,9	235,2	207,7		
TDV220 03/3A	250	335	359,9	338,3	330,4	322,0	312,9	303,1	292,3	278,0	257,4	229,9	202,1	
TDV220 04/4B	250	335	379,6	361,7	352,6	342,2	330,5	317,3	302,3	282,4				
TDV220 04/1A3B	250	335	404,7	384,0	374,6	364,0	352,2	339,0	324,2	304,5	276,5			
TDV220 04/2A2B	315	422	429,7	406,4	396,6	385,7	373,9	360,7	346,0	326,5	298,8			
TDV220 04/3A1B	315	422	454,8	428,8	418,6	407,5	395,5	382,5	367,9	348,6	321,0	284,3		
TDV220 04/4A	315	422	479,9	451,1	440,6	429,3	417,2	404,2	389,7	370,7	343,3	306,5	269,4	
TDV220 05/1A4B	355	476	499,6	474,4	462,7	449,5	434,8	418,3	399,8	375,1				
TDV220 05/2A3B	355	476	524,6	496,8	484,7	471,3	456,5	440,1	421,6	397,2	362,3			
TDV220 05/3A2B	355	476	549,7	519,2	506,7	493,1	478,2	461,8	443,5	419,2	384,6			

Performances in compliance with ISO 9906 - Annex A.

tdv220-2p50-en_a_th

TDV280 SERIES HYDRAULIC PERFORMANCE TABLE AT 50 Hz, 2 POLES

PUMP TYPE	RATED POWER		Q = DELIVERY											
			l/min 0	2166,7	2833,3	3333,3	3750	4166,7	4583,3	5000	5416,7	5666,7	6000	
			m ³ /h 0	130	170	200	225	250	275	300	325	340	360	
kW		HP		H = TOTAL HEAD METRES COLUMN OF WATER										
TDV280 01/1D	45	60	65,0	56,9	51,1	46,0	41,2	36,0						
TDV280 01/1C	55	74	77,1	70,0	65,2	60,9	56,7	52,0	46,6	40,6				
TDV280 01/1B	75	101	92,0	85,1	81,0	77,3	73,7	69,7	65,1	59,8	53,7			
TDV280 01/1A	90	121	112,4	107,5	103,3	99,5	95,9	91,7	87,1	81,7	75,5	71,4	65,2	
TDV280 02/1C1D	90	121	142,0	126,9	116,4	106,9	97,9	88,0						
TDV280 02/2C	110	148	154,1	140,1	130,5	121,7	113,4	103,9	93,3					
TDV280 02/1B1C	110	148	169,1	155,1	146,2	138,2	130,4	121,6	111,7	100,4				
TDV280 02/2B	132	177	184,1	170,2	162,0	154,6	147,5	139,4	130,1	119,6	107,4			
TDV280 02/1A1B	160	215	204,4	192,6	184,3	176,8	169,6	161,4	152,1	141,5	129,2	121,0		
TDV280 02/2A	200	268	224,8	215,0	206,6	199,0	191,7	183,5	174,1	163,4	151,1	142,7	130,4	
TDV280 03/2B1C	200	268	261,1	240,3	227,2	215,4	204,1	191,3	176,8	160,2				
TDV280 03/3B	200	268	276,1	255,3	243,0	231,9	221,2	209,0	195,2	179,3	161,1			
TDV280 03/1A2B	250	335	296,5	277,7	265,3	254,1	243,3	231,1	217,2	201,2	182,9	170,6		
TDV280 03/2A1B	250	335	316,8	300,1	287,6	276,3	265,5	253,2	239,2	223,2	204,8	192,4		
TDV280 03/3A	315	422	337,2	322,5	309,9	298,5	287,6	275,2	261,2	245,1	226,6	214,1	195,7	
TDV280 04/4B	315	422	368,1	340,4	324,0	309,1	294,9	278,7	260,2	239,1				
TDV280 04/1A3B	315	422	388,5	362,8	346,3	331,4	317,0	300,8	282,2	261,0	236,6			
TDV280 04/2A2B	315	422	408,8	385,2	368,6	353,6	339,2	322,8	304,2	282,9	258,5	242,0		
TDV280 04/3A1B	355	476	429,2	407,6	390,9	375,8	361,3	344,9	326,2	304,9	280,3	263,7		
TDV280 04/4A	355	476	449,6	430,0	413,3	398,0	383,5	367,0	348,2	326,8	302,1	285,5	260,9	
TDV280 05/1A4B	355	476	480,5	447,9	427,3	408,6	390,8	370,5	347,3	320,8				
TDV280 05/2A3B	355	476	500,9	470,3	449,6	430,9	412,9	392,5	369,3	342,7				

Performances in compliance with ISO 9906 - Annex A.

tdv280-2p50-en_a_th

**TDB-TDV SERIES
HYDRAULIC PERFORMANCE RANGE AT 50 Hz, 4 POLES**

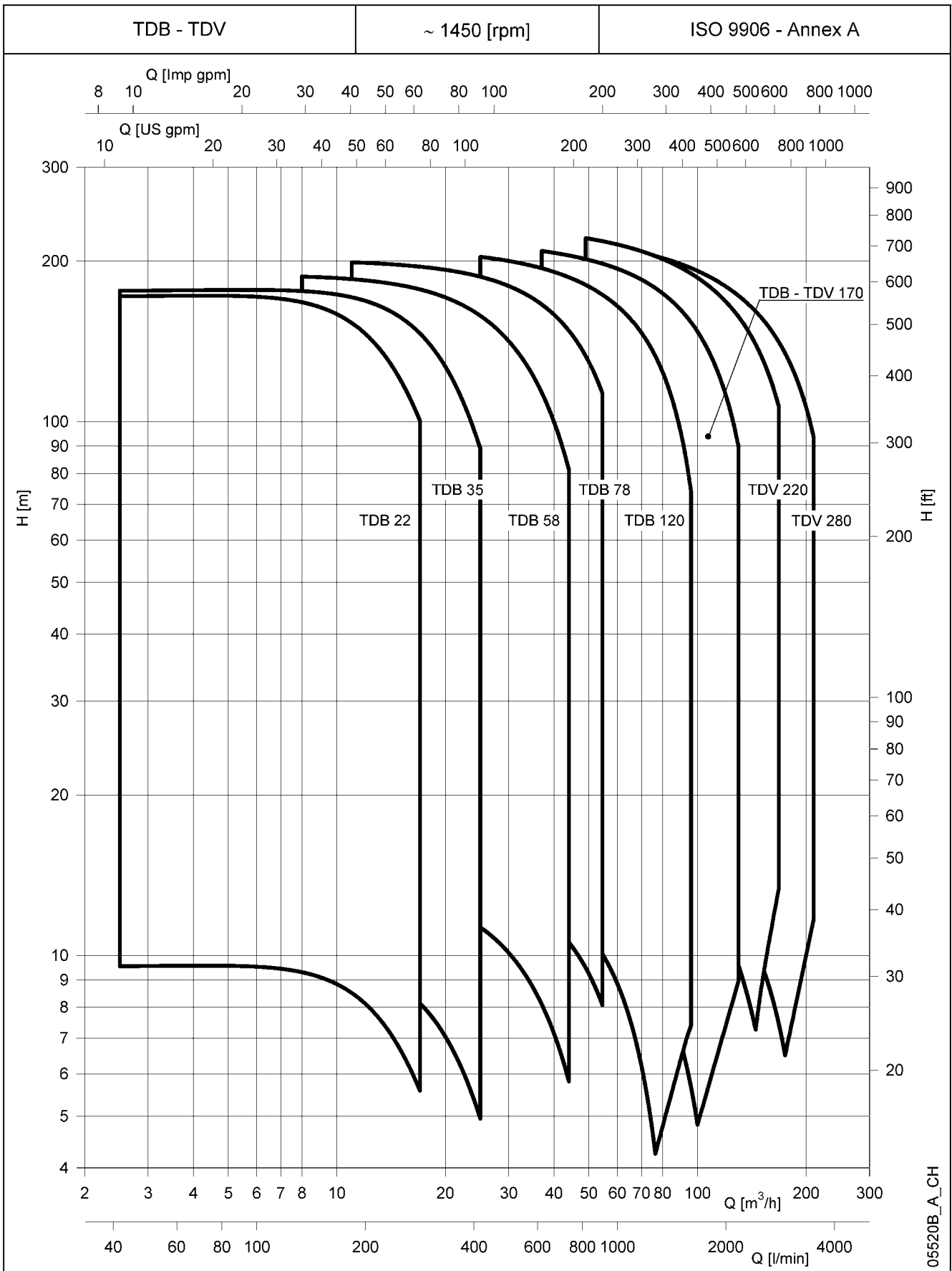

05520B_A_CH

These performances are valid for liquids with density $\rho = 1,0 \text{ Kg/dm}^3$ and kinematic viscosity $\nu = 1 \text{ mm}^2/\text{sec}$.

TDB22 SERIES HYDRAULIC PERFORMANCE TABLE AT 50 Hz, 4 POLES

PUMP TYPE	RATED POWER		Q = DELIVERY										
			l/min 0	41,7	66,7	83,3	100	133,3	166,7	200	233,3	266,7	283,3
	kW	HP	m ³ /h 0	2,5	4	5	6	8	10	12	14	16	17
H = TOTAL HEAD METRES COLUMN OF WATER													
TDB22 01/1A..4	1,1	1,5	9,6	9,6	9,6	9,6	9,5	9,3	8,8	8,1	7,2	6,1	5,6
TDB22 02/2A..4	1,1	1,5	19,2	19,1	19,2	19,1	19,1	18,6	17,7	16,2	14,4	12,2	11,2
TDB22 03/3A..4	1,5	2	28,9	28,7	28,7	28,7	28,6	27,9	26,5	24,4	21,6	18,4	16,7
TDB22 04/4A..4	2,2	3	38,5	38,2	38,3	38,3	38,1	37,2	35,4	32,5	28,7	24,5	22,3
TDB22 05/5A..4	3	4	48,1	47,8	47,9	47,9	47,7	46,6	44,2	40,6	35,9	30,6	27,9
TDB22 06/6A..4	3	4	57,7	57,3	57,5	57,4	57,2	55,9	53,1	48,7	43,1	36,7	33,5
TDB22 07/7A..4	4	5,4	67,4	66,9	67,0	67,0	66,7	65,2	61,9	56,9	50,3	42,8	39,1
TDB22 08/8A..4	5,5	7,4	77,0	76,5	76,6	76,6	76,3	74,5	70,8	65,0	57,5	49,0	44,7
TDB22 09/9A..4	5,5	7,4	86,6	86,0	86,2	86,2	85,8	83,8	79,6	73,1	64,7	55,1	50,2
TDB22 10/10A..4	5,5	7,4	96,2	95,6	95,8	95,7	95,3	93,1	88,5	81,2	71,9	61,2	55,8
TDB22 11/11A..4	7,5	10	105,9	105,1	105,3	105,3	104,9	102,4	97,3	89,4	79,0	67,3	61,4
TDB22 12/12A..4	7,5	10	115,5	114,7	114,9	114,9	114,4	111,7	106,1	97,5	86,2	73,4	67,0
TDB22 13/13A..4	7,5	10	125,1	124,2	124,5	124,4	124,0	121,1	115,0	105,6	93,4	79,6	72,6
TDB22 14/14A..4	7,5	10	134,7	133,8	134,1	134,0	133,5	130,4	123,8	113,7	100,6	85,7	78,1
TDB22 15/15A..4	11	15	144,3	143,3	143,7	143,6	143,0	139,7	132,7	121,9	107,8	91,8	83,7
TDB22 16/16A..4	11	15	154,0	152,9	153,2	153,2	152,6	149,0	141,5	130,0	115,0	97,9	89,3
TDB22 17/17A..4	11	15	163,6	162,5	162,8	162,7	162,1	158,3	150,4	138,1	122,2	104,0	94,9
TDB22 18/18A..4	11	15	173,2	172,0	172,4	172,3	171,6	167,6	159,2	146,2	129,3	110,2	100,5

Performances in compliance with ISO 9906 - Annex A.

tdb22-4p50-en_a_th

TDB35 SERIES HYDRAULIC PERFORMANCE TABLE AT 50 Hz, 4 POLES

PUMP TYPE	RATED POWER		Q = DELIVERY										
			l/min 0	41,7	66,7	100	150	200	250	300	333,3	366,7	416,7
	kW	HP	m ³ /h 0	2,5	4	6	9	12	15	18	20	22	25
H = TOTAL HEAD METRES COLUMN OF WATER													
TDB35 01/1A..4	1,1	1,5	9,8	9,8	9,8	9,8	9,7	9,4	8,7	7,8	7,0	6,2	4,9
TDB35 02/2A..4	1,5	2	19,6	19,6	19,6	19,6	19,4	18,7	17,5	15,6	14,1	12,4	9,9
TDB35 03/3A..4	2,2	3	29,4	29,4	29,4	29,5	29,1	28,1	26,2	23,4	21,1	18,7	14,8
TDB35 04/4A..4	3	4	39,2	39,1	39,2	39,3	38,9	37,5	34,9	31,2	28,2	24,9	19,8
TDB35 05/5A..4	4	5,4	49,0	48,9	49,0	49,1	48,6	46,8	43,6	39,0	35,2	31,1	24,7
TDB35 06/6A..4	4	5,4	58,8	58,7	58,8	58,9	58,3	56,2	52,4	46,8	42,3	37,3	29,7
TDB35 07/7A..4	5,5	7,4	68,6	68,5	68,6	68,7	68,0	65,6	61,1	54,6	49,3	43,6	34,6
TDB35 08/8A..4	5,5	7,4	78,4	78,3	78,5	78,6	77,7	74,9	69,8	62,4	56,4	49,8	39,6
TDB35 09/9A..4	7,5	10	88,1	88,1	88,3	88,4	87,4	84,3	78,6	70,2	63,4	56,0	44,5
TDB35 10/10A..4	7,5	10	97,9	97,8	98,1	98,2	97,1	93,7	87,3	78,0	70,5	62,2	49,5
TDB35 11/11A..4	7,5	10	107,7	107,6	107,9	108,0	106,8	103,0	96,0	85,8	77,5	68,5	54,4
TDB35 12/12A..4	11	15	117,5	117,4	117,7	117,8	116,6	112,4	104,7	93,6	84,6	74,7	59,4
TDB35 13/13A..4	11	15	127,3	127,2	127,5	127,6	126,3	121,8	113,5	101,4	91,6	80,9	64,3
TDB35 14/14A..4	11	15	137,1	137,0	137,3	137,5	136,0	131,1	122,2	109,2	98,7	87,1	69,3
TDB35 15/15A..4	11	15	146,9	146,8	147,1	147,3	145,7	140,5	130,9	117,0	105,7	93,3	74,2
TDB35 16/16A..4	11	15	156,7	156,6	156,9	157,1	155,4	149,9	139,6	124,8	112,8	99,6	79,2
TDB35 17/17A..4	15	20	166,5	166,3	166,7	166,9	165,1	159,2	148,4	132,6	119,8	105,8	84,1
TDB35 18/18A..4	15	20	176,3	176,1	176,5	176,7	174,8	168,6	157,1	140,4	126,9	112,0	89,1

Performances in compliance with ISO 9906 - Annex A.

tdb35-4p50-en_a_th

TDB58 SERIES HYDRAULIC PERFORMANCE TABLE AT 50 Hz, 4 POLES

PUMP TYPE	RATED POWER		Q = DELIVERY										
			l/min 0	133,3	166,7	208,3	250	333,3	416,7	500	583,3	666,7	733,3
	kW	HP	m ³ /h 0	8	10	12,5	15	20	25	30	35	40	44
H = TOTAL HEAD METRES COLUMN OF WATER													
TDB58 01/1A..4	2,2	3	13,4	13,4	13,3	13,1	12,9	12,2	11,3	10,1	8,7	7,1	5,8
TDB58 02/2A..4	3	4	26,8	26,7	26,6	26,2	25,8	24,4	22,6	20,2	17,4	14,3	11,6
TDB58 03/3A..4	4	5,4	40,2	40,1	39,9	39,4	38,7	36,7	33,9	30,3	26,1	21,4	17,4
TDB58 04/4A..4	5,5	7,4	53,5	53,5	53,1	52,5	51,5	48,9	45,2	40,5	34,9	28,6	23,2
TDB58 05/5A..4	7,5	10	66,9	66,9	66,4	65,6	64,4	61,1	56,5	50,6	43,6	35,7	29,1
TDB58 06/6A..4	11	15	80,3	80,2	79,7	78,7	77,3	73,3	67,8	60,7	52,3	42,9	34,9
TDB58 07/7A..4	11	15	93,7	93,6	93,0	91,8	90,2	85,6	79,1	70,8	61,0	50,0	40,7
TDB58 08/8A..4	11	15	107,1	107,0	106,3	104,9	103,1	97,8	90,4	80,9	69,7	57,2	46,5
TDB58 09/9A..4	15	20	120,5	120,4	119,6	118,1	116,0	110,0	101,6	91,0	78,4	64,3	52,3
TDB58 10/10A..4	15	20	133,8	133,7	132,8	131,2	128,9	122,2	112,9	101,1	87,1	71,5	58,1
TDB58 11/11A..4	15	20	147,2	147,1	146,1	144,3	141,7	134,5	124,2	111,3	95,9	78,6	63,9
TDB58 12/12A..4	18,5	25	160,6	160,5	159,4	157,4	154,6	146,7	135,5	121,4	104,6	85,7	69,7
TDB58 13/13A..4	18,5	25	174,0	173,9	172,7	170,5	167,5	158,9	146,8	131,5	113,3	92,9	75,5
TDB58 14/14A..4	22	30	187,4	187,2	186,0	183,6	180,4	171,1	158,1	141,6	122,0	100,0	81,4

Performances in compliance with ISO 9906 - Annex A.

tdb58-4p50-en_a_th

TDB78 SERIES HYDRAULIC PERFORMANCE TABLE AT 50 Hz, 4 POLES

PUMP TYPE	RATED POWER		Q = DELIVERY										
			l/min 0	183,3	250	333,3	416,7	500	583,3	666,7	750	833,3	908,3
	kW	HP	m ³ /h 0	11	15	20	25	30	35	40	45	50	54,5
H = TOTAL HEAD METRES COLUMN OF WATER													
TDB78 01/1A..4	2,2	3	14,4	14,2	14,1	13,8	13,4	12,8	12,2	11,4	10,4	9,2	8,1
TDB78 02/2A..4	4	5,4	28,9	28,4	28,1	27,5	26,7	25,7	24,3	22,7	20,8	18,5	16,2
TDB78 03/3A..4	7,5	10	43,3	42,7	42,2	41,3	40,1	38,5	36,5	34,1	31,1	27,7	24,2
TDB78 04/4A..4	11	15	57,7	56,9	56,2	55,1	53,5	51,3	48,7	45,4	41,5	37,0	32,3
TDB78 05/5A..4	11	15	72,2	71,1	70,3	68,8	66,8	64,2	60,8	56,8	51,9	46,2	40,4
TDB78 06/6A..4	15	20	86,6	85,3	84,4	82,6	80,2	77,0	73,0	68,1	62,3	55,5	48,5
TDB78 07/7A..4	15	20	101,1	99,6	98,4	96,4	93,5	89,8	85,2	79,5	72,7	64,7	56,6
TDB78 08/8A..4	18,5	25	115,5	113,8	112,5	110,1	106,9	102,7	97,3	90,8	83,0	74,0	64,6
TDB78 09/9A..4	18,5	25	129,9	128,0	126,5	123,9	120,3	115,5	109,5	102,2	93,4	83,2	72,7
TDB78 10/10A..4	22	30	144,4	142,2	140,6	137,7	133,6	128,3	121,7	113,5	103,8	92,4	80,8
TDB78 11/11A..4	22	30	158,8	156,5	154,6	151,4	147,0	141,2	133,8	124,9	114,2	101,7	88,9
TDB78 12/12A..4	30	40	173,2	170,7	168,7	165,2	160,4	154,0	146,0	136,2	124,6	110,9	97,0
TDB78 13/13A..4	30	40	187,7	184,9	182,8	179,0	173,7	166,8	158,2	147,6	134,9	120,2	105,0
TDB78 14/14A..4	30	40	202,1	199,1	196,8	192,7	187,1	179,7	170,3	158,9	145,3	129,4	113,1

Performances in compliance with ISO 9906 - Annex A.

tdb78-4p50-en_a_th

TDB120 SERIES HYDRAULIC PERFORMANCE TABLE AT 50 Hz, 4 POLES

PUMP TYPE	RATED POWER		Q = DELIVERY										
			l/min 0	416,7	500	583,3	666,7	833,3	1000	1166,7	1266,7	1450	1600
			m ³ /h 0	25	30	35	40	50	60	70	76	87	96
kW		HP	H = TOTAL HEAD METRES COLUMN OF WATER										
TDB120 01/1C..4	11	15	13,9	13,5	13,3	12,9	12,4	10,9	8,8	6,2	4,4		
TDB120 01/1B..4	11	15	17,2	16,6	16,3	15,9	15,5	14,3	12,6	10,4	8,9	5,5	
TDB120 01/1A..4	11	15	20,9	20,4	20,0	19,6	19,1	17,9	16,5	14,7	13,4	10,5	7,4
TDB120 02/2B..4	11	15	34,3	33,2	32,6	31,9	30,9	28,5	25,2	20,9	17,8	11,1	
TDB120 02/2A..4	11	15	41,8	40,8	40,0	39,2	38,2	35,9	33,0	29,3	26,8	20,9	14,8
TDB120 03/1A2B..4	15	20	55,2	53,6	52,6	51,5	50,1	46,4	41,7	35,5	31,1	21,5	
TDB120 03/3A..4	15	20	62,6	61,1	60,1	58,8	57,3	53,8	49,4	44,0	40,1	31,4	22,2
TDB120 04/2A2B..4	18,5	25	76,1	73,9	72,6	71,0	69,2	64,4	58,1	50,2	44,5	32,0	
TDB120 04/4A..4	18,5	25	83,5	81,5	80,1	78,4	76,4	71,7	65,9	58,7	53,5	41,8	29,6
TDB120 05/3A2B..4	22	30	97,0	94,3	92,7	90,6	88,3	82,3	74,6	64,9	57,9	42,4	
TDB120 05/5A..4	22	30	104,4	101,9	100,1	98,0	95,5	89,7	82,4	73,4	66,9	52,3	37,0
TDB120 06/4A2B..4	30	40	117,8	114,7	112,7	110,2	107,4	100,2	91,1	79,6	71,3	52,9	
TDB120 06/6A..4	30	40	125,3	122,3	120,1	117,6	114,6	107,6	98,9	88,0	80,3	62,7	44,4
TDB120 07/5A2B..4	30	40	138,7	135,1	132,7	129,8	126,5	118,2	107,6	94,2	84,6	63,4	
TDB120 07/7A..4	37	50	146,1	142,7	140,1	137,1	133,7	125,5	115,3	102,7	93,6	73,2	51,8
TDB120 08/6A2B..4	37	50	159,6	155,4	152,7	149,4	145,6	136,1	124,0	108,9	98,0	73,8	
TDB120 08/8A..4	37	50	167,0	163,0	160,2	156,7	152,8	143,4	131,8	117,4	107,0	83,6	59,2
TDB120 09/7A2B..4	45	60	180,5	175,8	172,7	169,0	164,7	154,0	140,5	123,6	111,4	84,3	
TDB120 09/9A..4	45	60	187,9	183,4	180,2	176,3	171,9	161,4	148,3	132,0	120,4	94,1	66,6
TDB120 10/8A2B..4	45	60	201,4	196,2	192,8	188,6	183,8	172,0	157,0	138,2	124,8	94,7	
TDB120 10/10A..4	45	60	208,8	203,8	200,2	195,9	191,0	179,3	164,8	146,7	133,8	104,6	74,0

Performances in compliance with ISO 9906 - Annex A.

tdb120-4p50-en_a_th

TDB-TDV170 SERIES HYDRAULIC PERFORMANCE TABLE AT 50 Hz, 4 POLES

PUMP TYPE	RATED POWER		Q = DELIVERY										
			l/min 0	616,7	666,7	833,3	1000	1166,7	1333,3	1500	1666,7	1916,7	2166,7
			m ³ /h 0	37	40	50	60	70	80	90	100	115	130
kW		HP	H = TOTAL HEAD METRES COLUMN OF WATER										
TDB170 01/1C..4	11	15	13,5	12,8	12,7	12,0	11,1	10,0	8,6	6,8	4,8		
TDB170 01/1B..4	11	15	16,5	16,0	15,9	15,4	14,7	13,7	12,5	11,0	9,2	6,0	
TDB170 01/1A..4	11	15	22,2	20,9	20,7	20,1	19,4	18,5	17,4	16,2	14,8	12,2	9,0
TDB170 02/2B..4	11	15	33,1	32,0	31,7	30,7	29,3	27,4	25,0	22,0	18,4	11,9	
TDB170 02/2A..4	11	15	44,4	41,8	41,5	40,2	38,7	36,9	34,8	32,4	29,5	24,4	17,9
TDB170 03/1A2B..4	15	20	55,3	52,9	52,5	50,8	48,7	45,9	42,4	38,2	33,2	24,1	
TDB170 03/3A..4	18,5	25	66,6	62,7	62,2	60,3	58,1	55,4	52,3	48,6	44,3	36,5	26,9
TDB170 04/2A2B..4	22	30	77,5	73,8	73,2	71,0	68,0	64,4	59,8	54,4	47,9	36,3	
TDB170 04/4A..4	30	40	88,8	83,6	83,0	80,4	77,4	73,9	69,7	64,8	59,1	48,7	35,9
TDB170 05/3A2B..4	30	40	99,7	94,7	94,0	91,1	87,4	82,8	77,2	70,6	62,7	48,5	
TDB170 05/5A..4	30	40	111,0	104,5	103,7	100,6	96,8	92,4	87,1	81,0	73,8	60,9	44,9
TDB170 06/4A2B..4	37	50	121,9	115,6	114,7	111,2	106,8	101,3	94,7	86,8	77,5	60,7	
TDB170 06/6A..4	37	50	133,2	125,4	124,4	120,7	116,2	110,8	104,5	97,2	88,6	73,1	53,8
TDB170 07/5A2B..4	37	50	144,1	136,5	135,4	131,3	126,1	119,8	112,1	103,0	92,2	72,8	
TDB170 07/7A..4	45	60	155,4	146,3	145,2	140,8	135,5	129,3	122,0	113,4	103,4	85,3	62,8
TDB170 08/6A2B..4	45	60	166,2	157,4	156,2	151,4	145,5	138,2	129,5	119,2	107,0	85,0	
TDB170 08/8A..4	55	74	177,5	167,2	165,9	160,9	154,9	147,8	139,4	129,6	118,1	97,5	71,8
TDB170 09/7A2B..4	55	74	188,4	178,3	176,9	171,5	164,8	156,7	146,9	135,4	121,8	97,2	
TDB170 09/9A..4	55	74	199,7	188,1	186,7	181,0	174,2	166,2	156,8	145,8	132,9	109,6	80,8
TDB170 10/8A2B..4	55	74	210,6	199,2	197,7	191,6	184,2	175,2	164,4	151,6	136,5	109,4	
TDV170 10/10A..4	75	101	221,9	209,1	207,4	201,1	193,6	184,7	174,2	162,0	147,7	121,8	89,7

Performances in compliance with ISO 9906 - Annex A.

tdb-tdv170-4p50-en_a_th

TDV220 SERIES HYDRAULIC PERFORMANCE TABLE AT 50 Hz, 4 POLES

PUMP TYPE	RATED POWER		Q = DELIVERY										
			l/min 0	816,7	916,7	1166,7	1416,7	1666,7	1916,7	2166,7	2416,7	2583,3	2800
	kW	HP	m ³ /h 0	49	55	70	85	100	115	130	145	155	168
H = TOTAL HEAD METRES COLUMN OF WATER													
TDV220 01/1C..4	11	15	19,4	18,2	17,9	16,8	15,4	13,7	11,7	9,6	7,3		
TDV220 01/1B..4	11	15	23,4	22,3	21,9	20,9	19,6	18,0	16,1	14,0	11,7	10,0	
TDV220 01/1A..4	11	15	29,3	27,6	27,2	26,1	24,8	23,3	21,6	19,7	17,5	15,8	13,4
TDV220 02/2B..4	15	20	46,8	44,5	43,9	41,8	39,1	35,9	32,2	28,0	23,4	20,0	
TDV220 02/2A..4	22	30	58,6	55,2	54,4	52,2	49,6	46,6	43,2	39,3	34,9	31,6	26,7
TDV220 03/1A2B..4	30	40	76,1	72,1	71,1	67,9	63,9	59,2	53,8	47,7	40,8	35,8	
TDV220 03/3A..4	30	40	87,9	82,8	81,7	78,3	74,4	69,9	64,8	59,0	52,4	47,4	40,1
TDV220 04/2A2B..4	37	50	105,3	99,8	98,3	94,0	88,7	82,5	75,4	67,4	58,3	51,6	
TDV220 04/4A..4	45	60	117,2	110,5	108,9	104,4	99,1	93,2	86,4	78,7	69,8	63,2	53,5
TDV220 05/3A2B..4	45	60	134,6	127,4	125,5	120,0	113,5	105,8	97,0	87,0	75,8	67,4	
TDV220 05/5A..4	55	74	146,5	138,1	136,1	130,5	123,9	116,5	108,0	98,4	87,3	79,0	66,8
TDV220 06/4A2B..4	55	74	163,9	155,0	152,7	146,1	138,3	129,1	118,6	106,7	93,2	83,2	
TDV220 06/6A..4	75	101	175,8	165,7	163,3	156,6	148,7	139,7	129,6	118,0	104,8	94,8	80,2
TDV220 07/5A2B..4	75	101	193,2	182,6	180,0	172,2	163,0	152,4	140,2	126,4	110,7	99,0	
TDV220 07/7A..4	75	101	205,0	193,3	190,5	182,7	173,5	163,0	151,2	137,7	122,2	110,6	93,5
TDV220 08/6A2B..4	75	101	222,5	210,2	207,2	198,3	187,8	175,7	161,8	146,1	128,1	114,8	
TDV220 08/8A..4	90	121	234,3	220,9	217,8	208,8	198,3	186,3	172,8	157,4	139,7	126,4	106,9

Performances in compliance with ISO 9906 - Annex A.

tdv220-4p50-en_a_th

TDV280 SERIES HYDRAULIC PERFORMANCE TABLE AT 50 Hz, 4 POLES

PUMP TYPE	RATED POWER		Q = DELIVERY										
			l/min 0	1066,7	1333,3	1666,7	1916,7	2166,7	2416,7	2666,7	2916,7	3166,7	3500
	kW	HP	m ³ /h 0	64	80	100	115	130	145	160	175	190	210
H = TOTAL HEAD METRES COLUMN OF WATER													
TDV280 01/1C..4	11	15	19,0	17,1	16,1	14,6	13,3	11,9	10,3	8,5	6,5		
TDV280 01/1B..4	11	15	22,8	21,1	20,2	18,9	17,8	16,5	14,9	13,2	11,1	8,8	
TDV280 01/1A..4	11	15	28,2	26,3	25,3	24,0	22,8	21,5	20,1	18,6	16,8	14,8	11,7
TDV280 02/2B..4	18,5	25	45,6	42,1	40,4	37,9	35,6	32,9	29,8	26,3	22,2	17,6	
TDV280 02/2A..4	22	30	56,4	52,6	50,7	48,0	45,6	43,1	40,3	37,1	33,6	29,6	23,4
TDV280 03/1A2B..4	30	40	73,8	68,4	65,8	61,9	58,4	54,5	50,0	44,9	39,0	32,4	
TDV280 03/3A..4	37	50	84,6	78,9	76,0	71,9	68,5	64,6	60,4	55,7	50,4	44,4	35,1
TDV280 04/2A2B..4	45	60	102,0	94,7	91,1	85,8	81,2	76,0	70,1	63,4	55,9	47,2	
TDV280 04/4A..4	45	60	112,8	105,2	101,4	95,9	91,3	86,2	80,5	74,3	67,2	59,2	46,8
TDV280 05/3A2B..4	55	74	130,2	121,0	116,5	109,8	104,0	97,6	90,3	82,0	72,7	62,0	
TDV280 05/5A..4	55	74	141,0	131,5	126,7	119,9	114,1	107,7	100,7	92,8	84,0	74,0	58,5
TDV280 06/4A2B..4	75	101	158,4	147,3	141,8	133,8	126,9	119,1	110,4	100,6	89,5	76,8	
TDV280 06/6A..4	75	101	169,2	157,7	152,1	143,9	136,9	129,3	120,8	111,4	100,8	88,8	70,2
TDV280 07/5A2B..4	75	101	186,6	173,6	167,2	157,8	149,7	140,7	130,5	119,1	106,3	91,6	
TDV280 07/7A..4	90	121	197,4	184,0	177,4	167,9	159,8	150,8	140,9	130,0	117,6	103,7	81,9
TDV280 08/6A2B..4	90	121	214,8	199,9	192,5	181,8	172,5	162,2	150,7	137,7	123,1	106,4	
TDV280 08/8A..4	90	121	225,6	210,3	202,8	191,9	182,6	172,4	161,1	148,5	134,4	118,5	93,6

Performances in compliance with ISO 9906 - Annex A.

tdv280-4p50-en_a_th

TDB22 SERIES OPERATING CHARACTERISTICS AT 50 Hz, 2 POLES

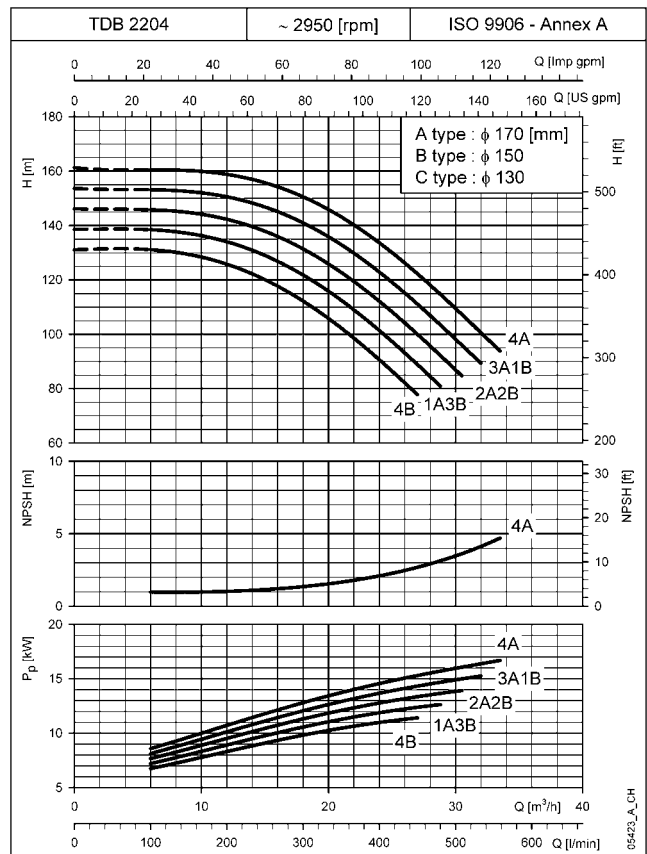
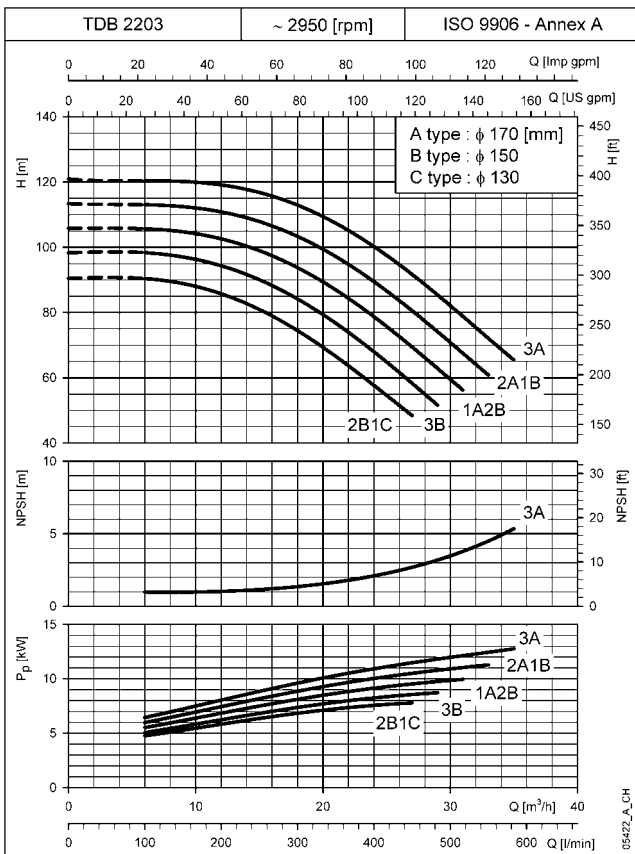
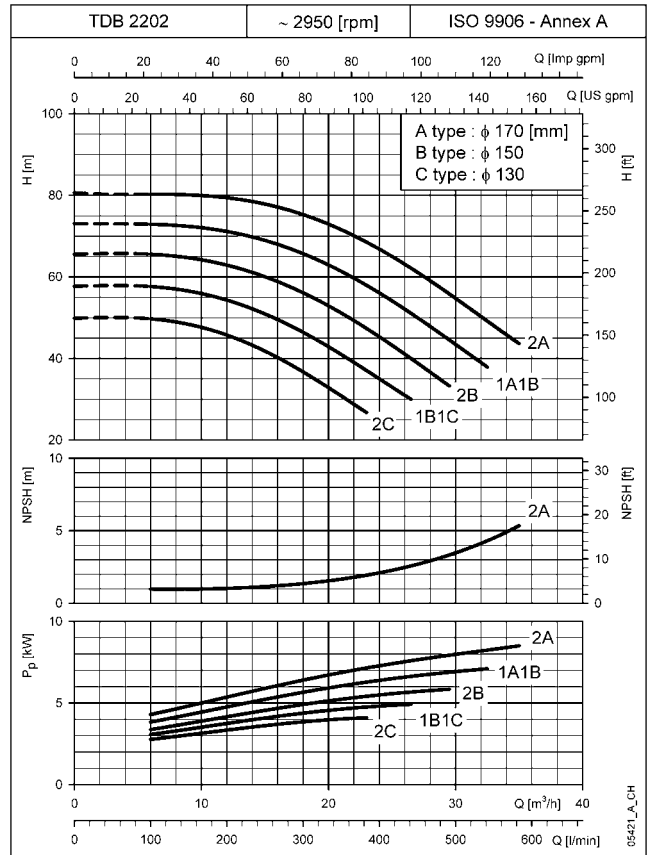
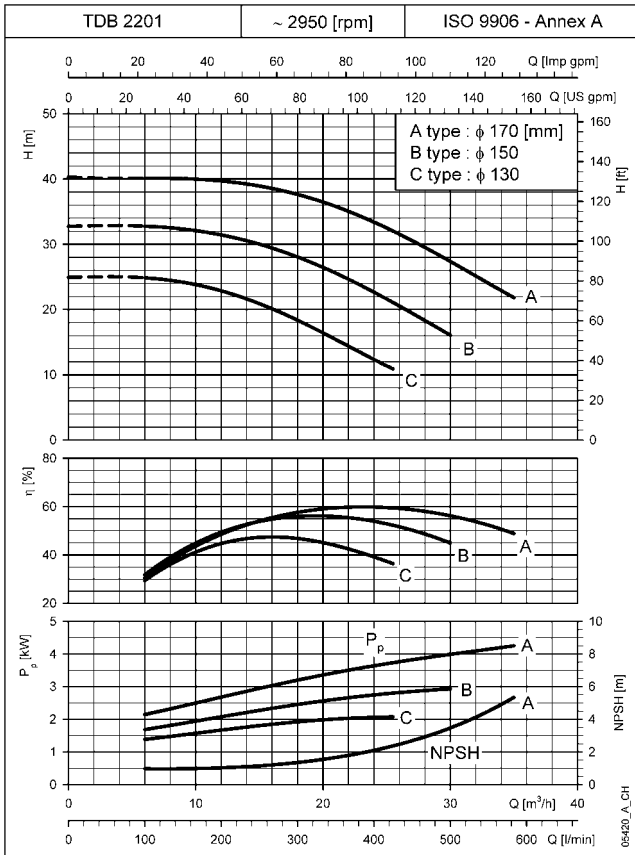

These performances are valid for liquids with density $\rho = 1,0 \text{ Kg/dm}^3$ and kinematic viscosity $\nu = 1 \text{ mm}^2/\text{sec}$.
The NPSH values are laboratory values; for practical use we suggest increasing these values by 0,5 m.

TDB22 SERIES OPERATING CHARACTERISTICS AT 50 Hz, 2 POLES

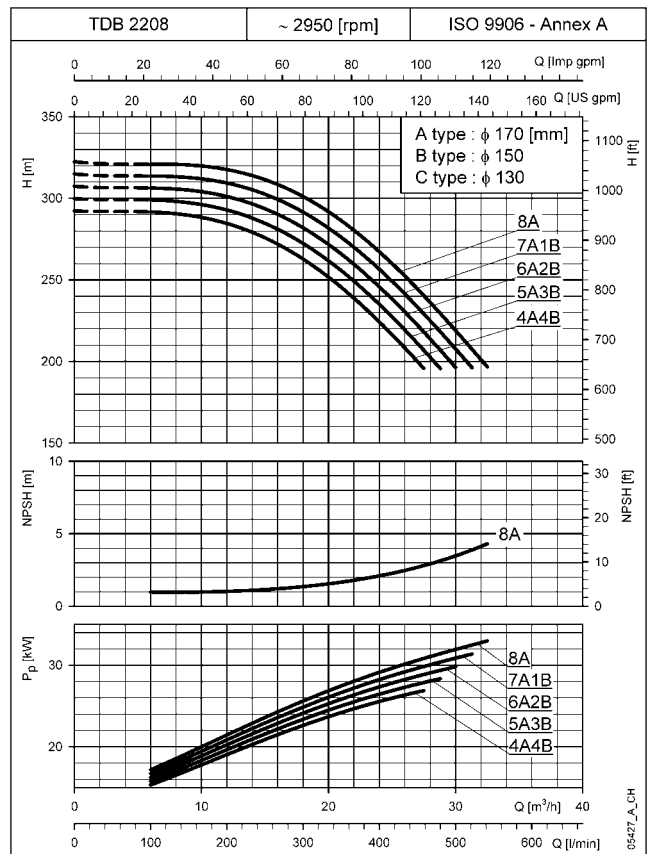
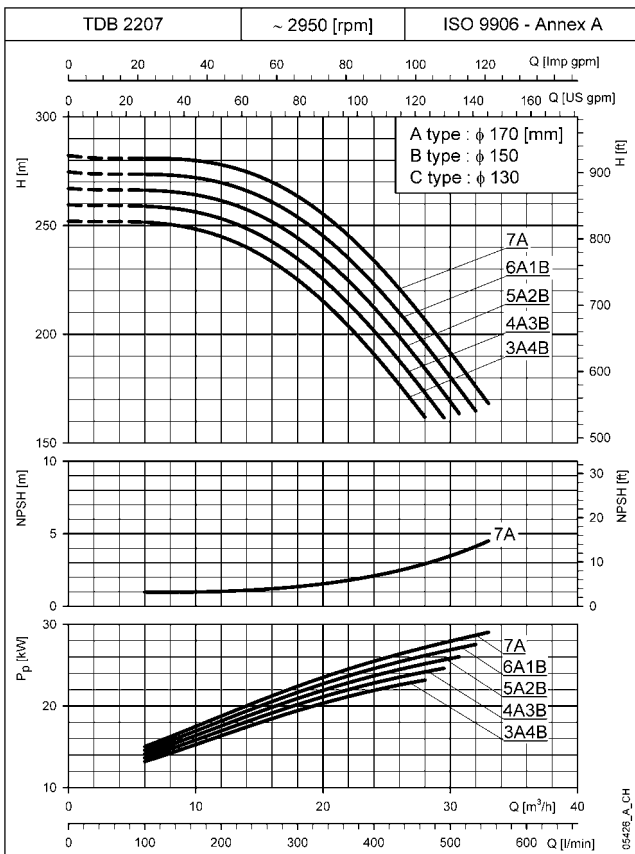
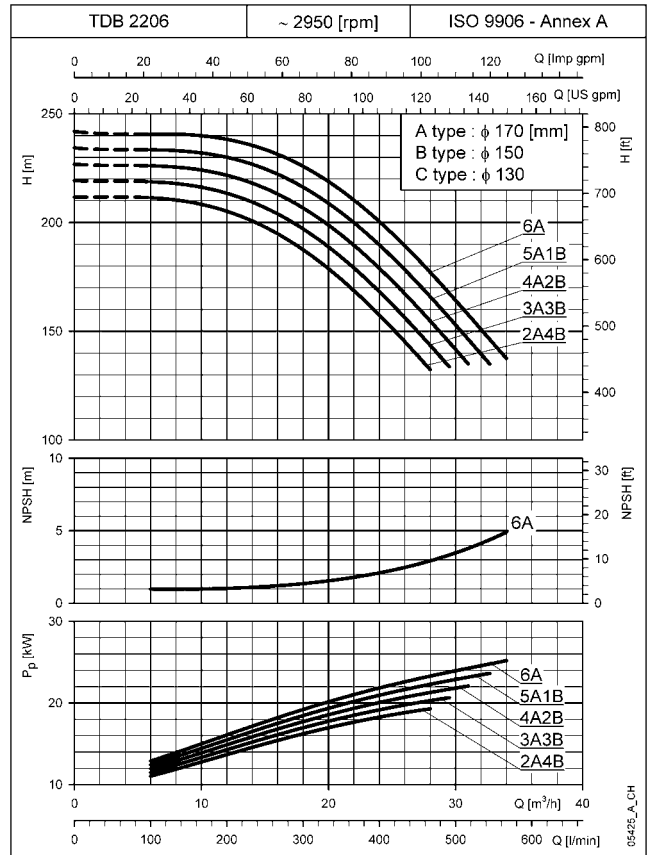
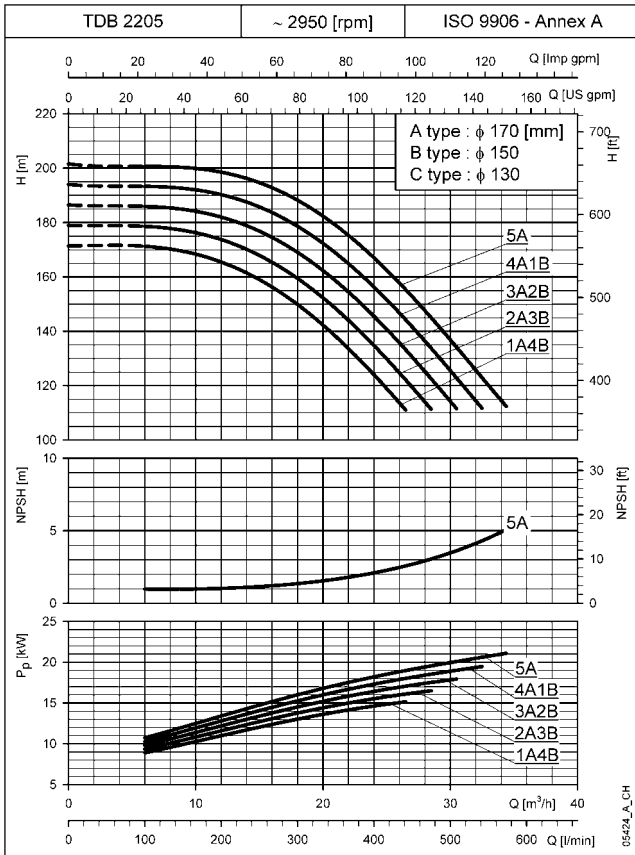

These performances are valid for liquids with density $\rho = 1,0 \text{ Kg/dm}^3$ and kinematic viscosity $\nu = 1 \text{ mm}^2/\text{sec}$.
The NPSH values are laboratory values; for practical use we suggest increasing these values by 0,5 m.

TDB22 SERIES OPERATING CHARACTERISTICS AT 50 Hz, 2 POLES

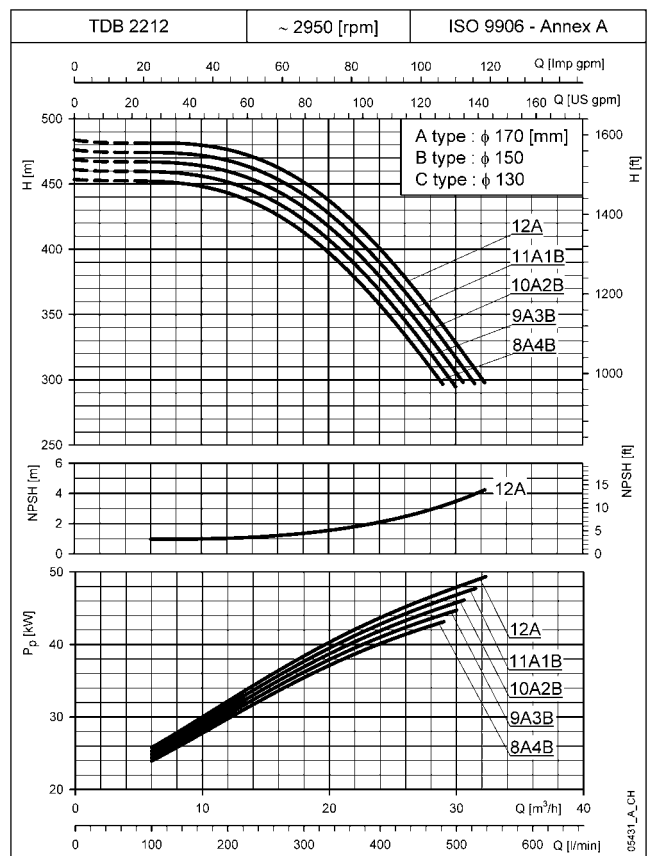
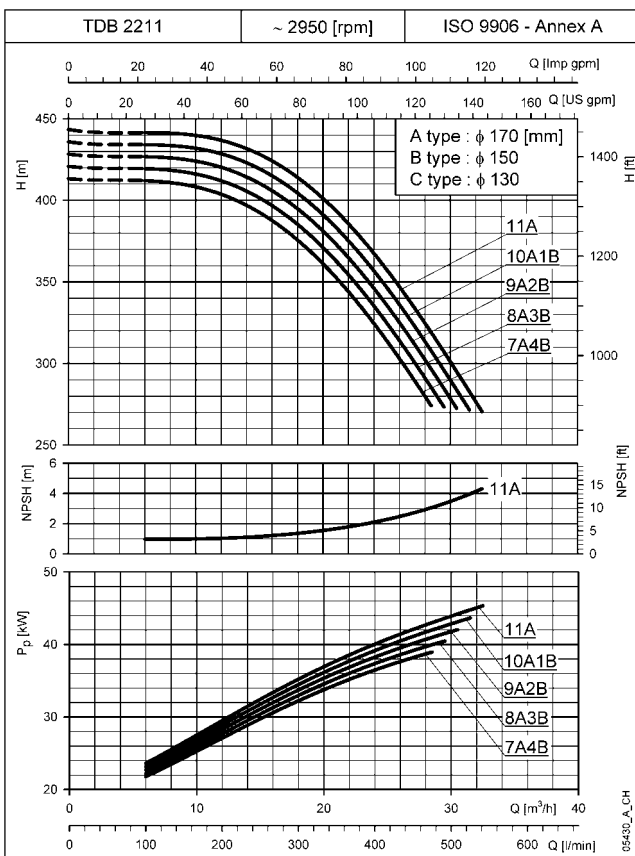
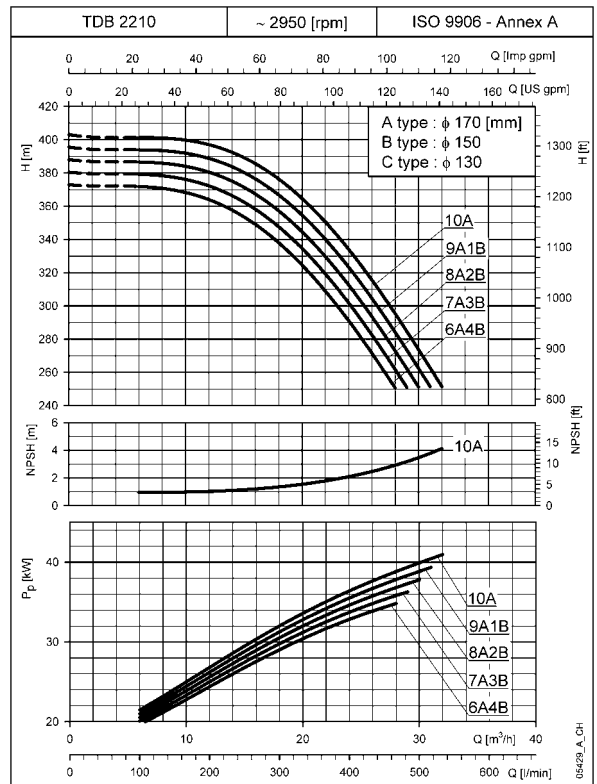
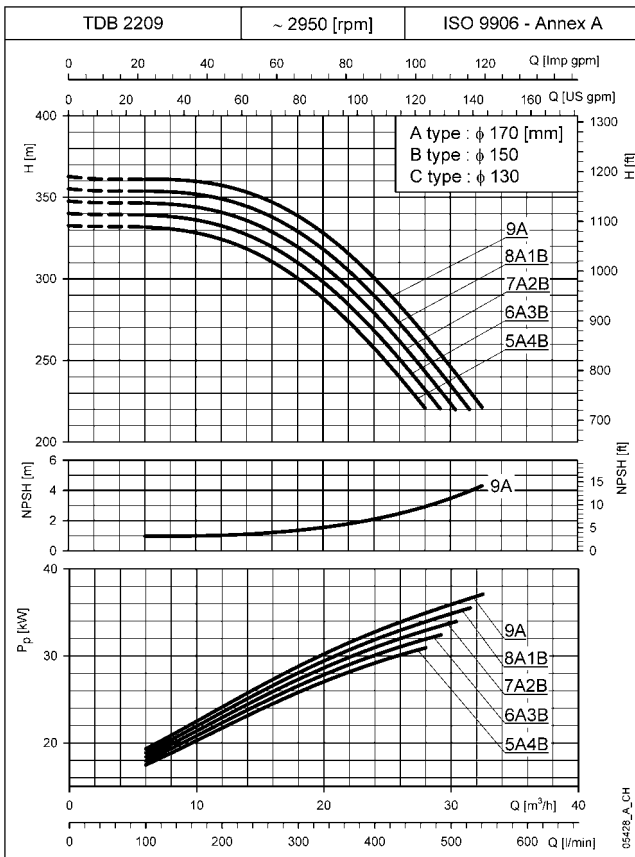

These performances are valid for liquids with density $\rho = 1,0 \text{ Kg/dm}^3$ and kinematic viscosity $\nu = 1 \text{ mm}^2/\text{sec}$.
 The NPSH values are laboratory values; for practical use we suggest increasing these values by 0,5 m.

TDB35 SERIES OPERATING CHARACTERISTICS AT 50 Hz, 2 POLES

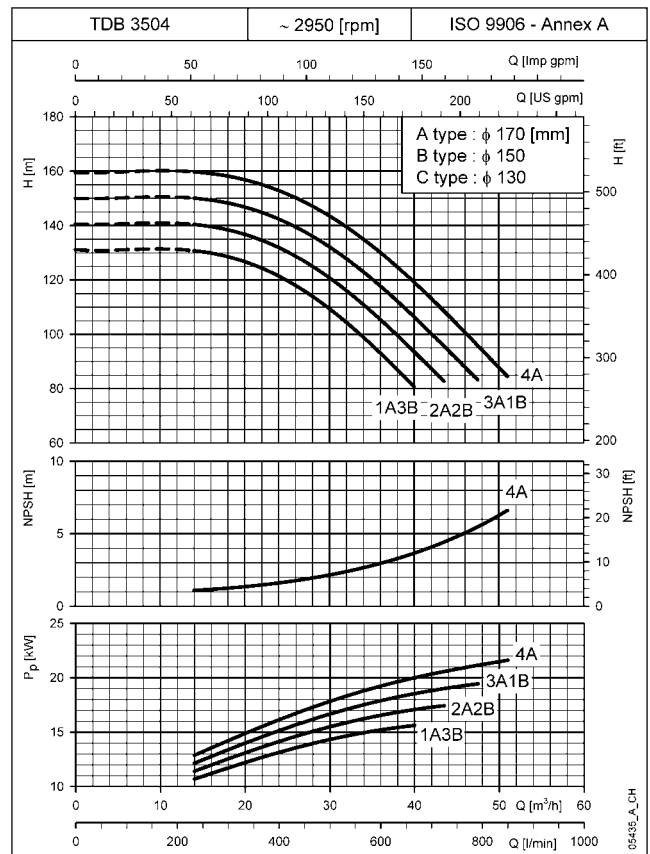
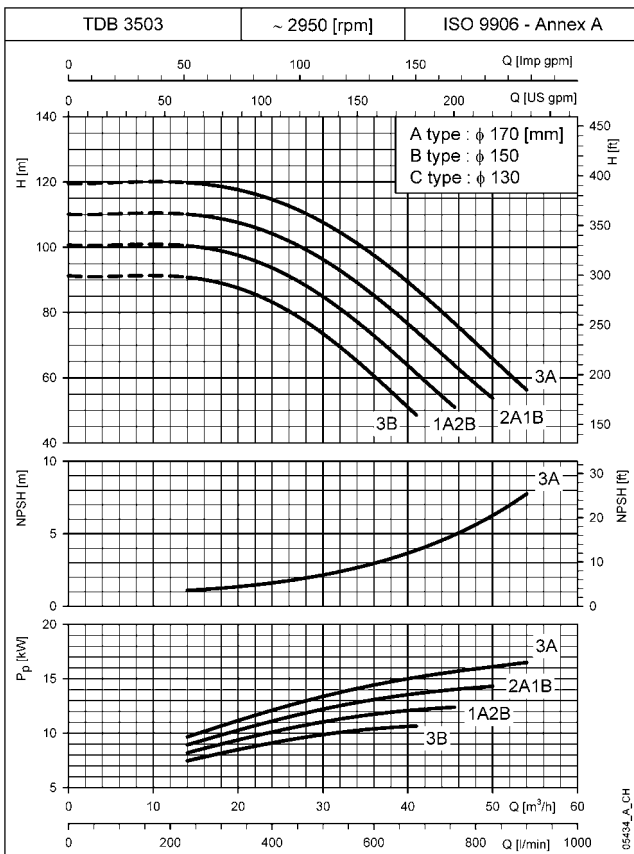
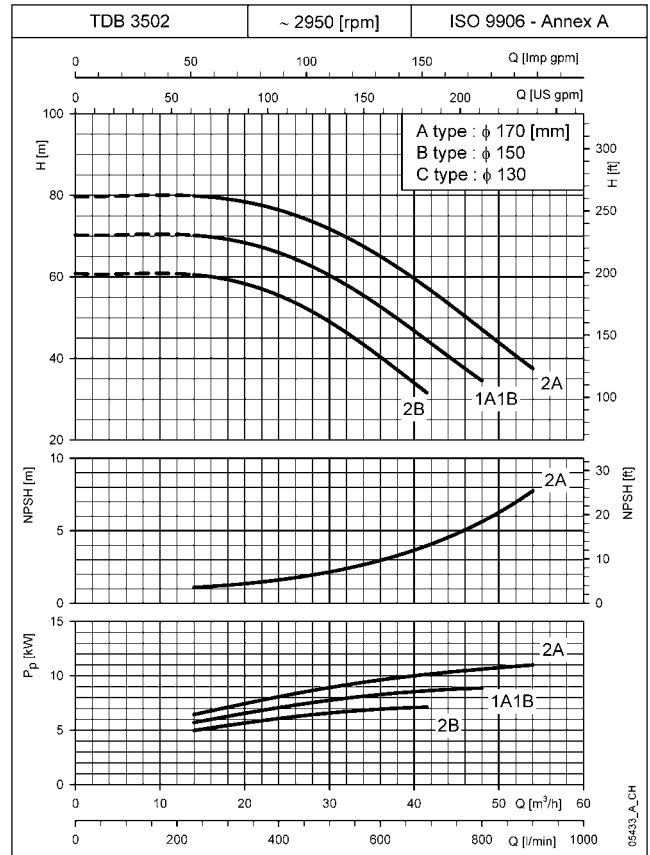
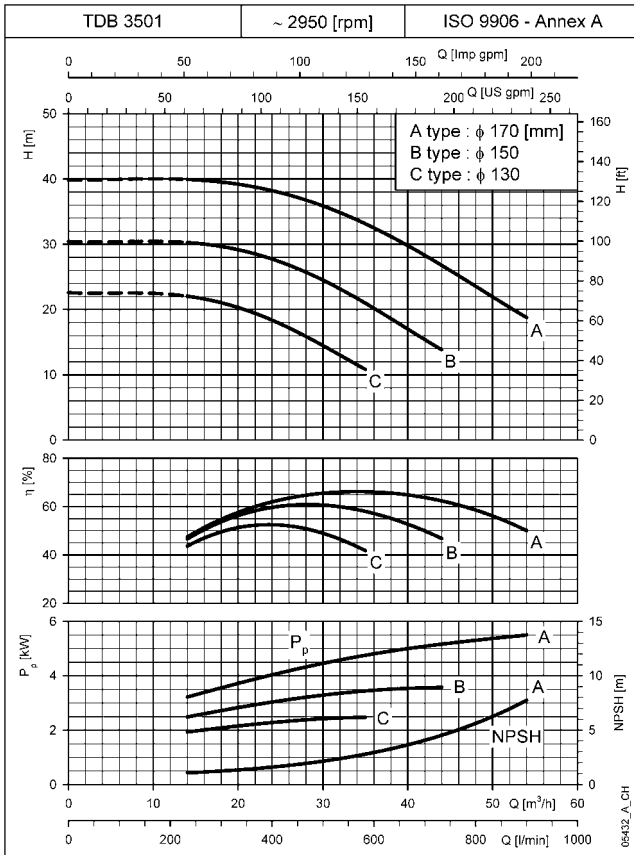

These performances are valid for liquids with density $\rho = 1,0 \text{ Kg/dm}^3$ and kinematic viscosity $\nu = 1 \text{ mm}^2/\text{sec}$.
The NPSH values are laboratory values; for practical use we suggest increasing these values by 0,5 m.

TDB35 SERIES OPERATING CHARACTERISTICS AT 50 Hz, 2 POLES

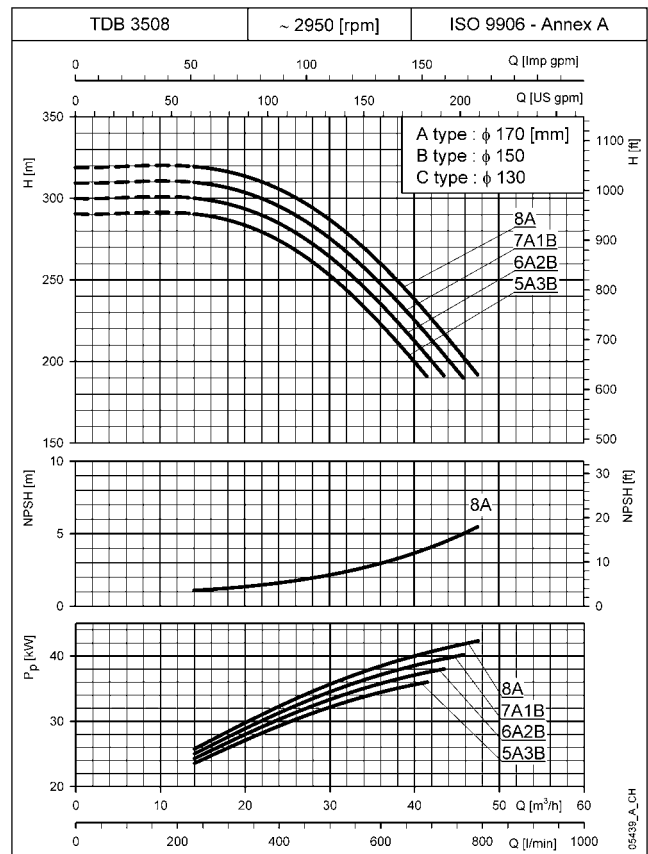
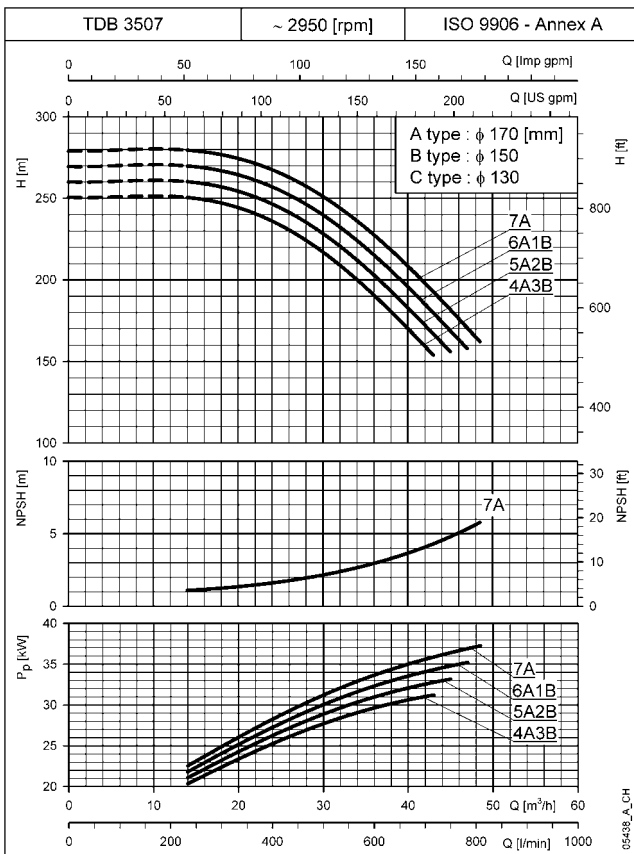
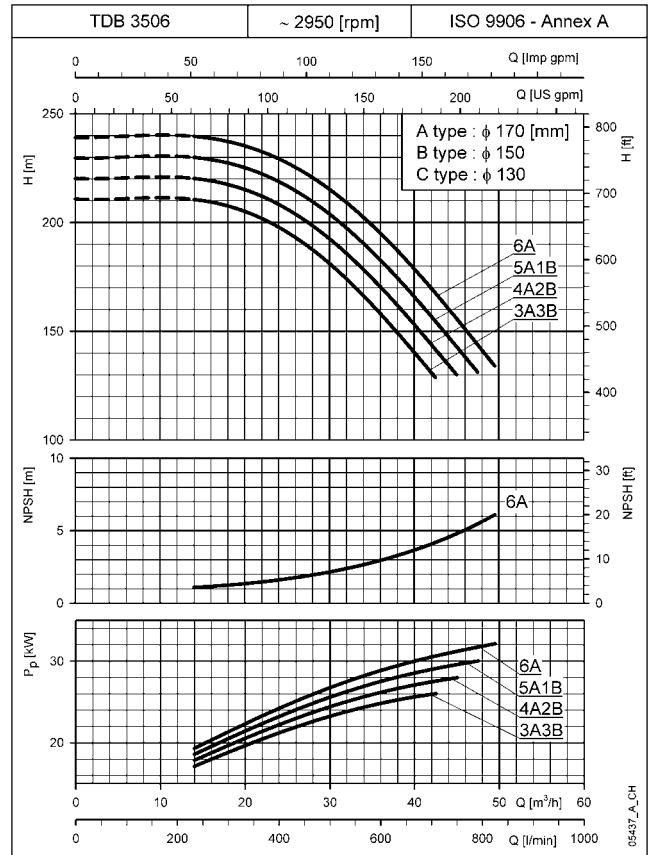
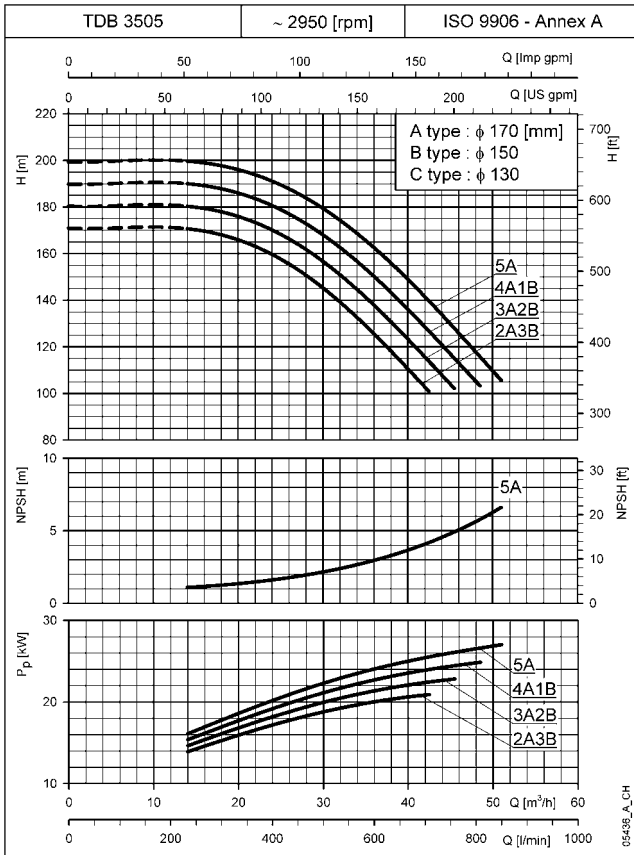

These performances are valid for liquids with density $\rho = 1,0 \text{ Kg/dm}^3$ and kinematic viscosity $\nu = 1 \text{ mm}^2/\text{sec}$.
The NPSH values are laboratory values; for practical use we suggest increasing these values by 0,5 m.

TDB35 SERIES OPERATING CHARACTERISTICS AT 50 Hz, 2 POLES

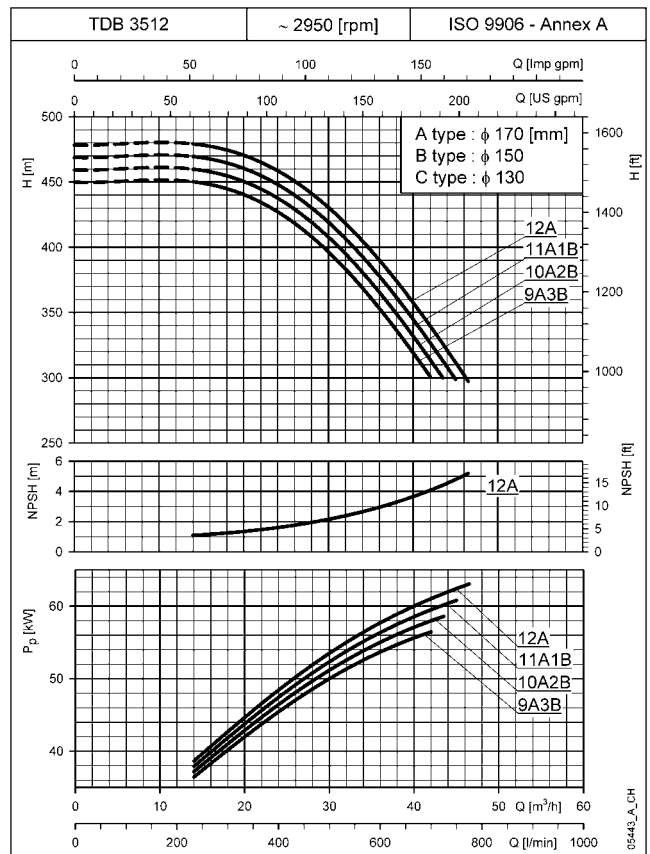
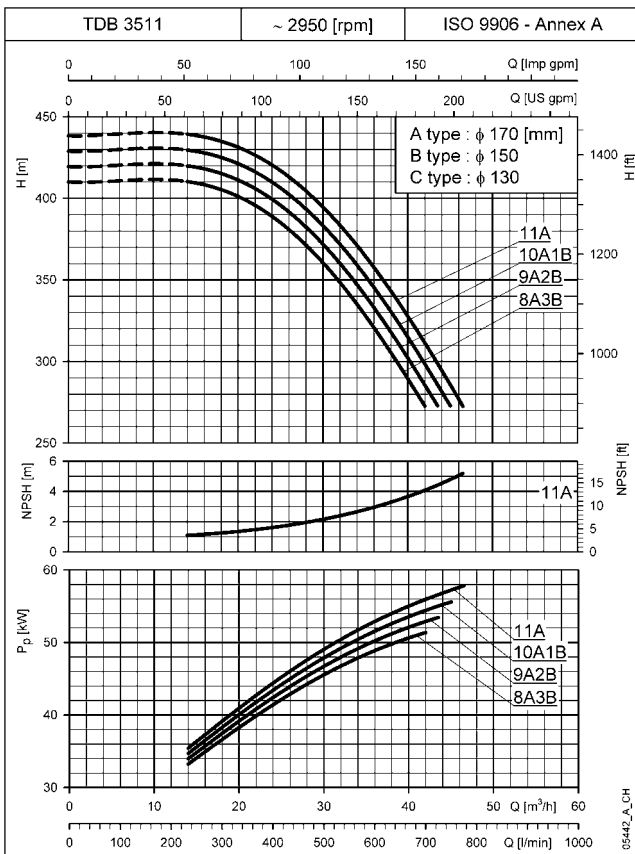
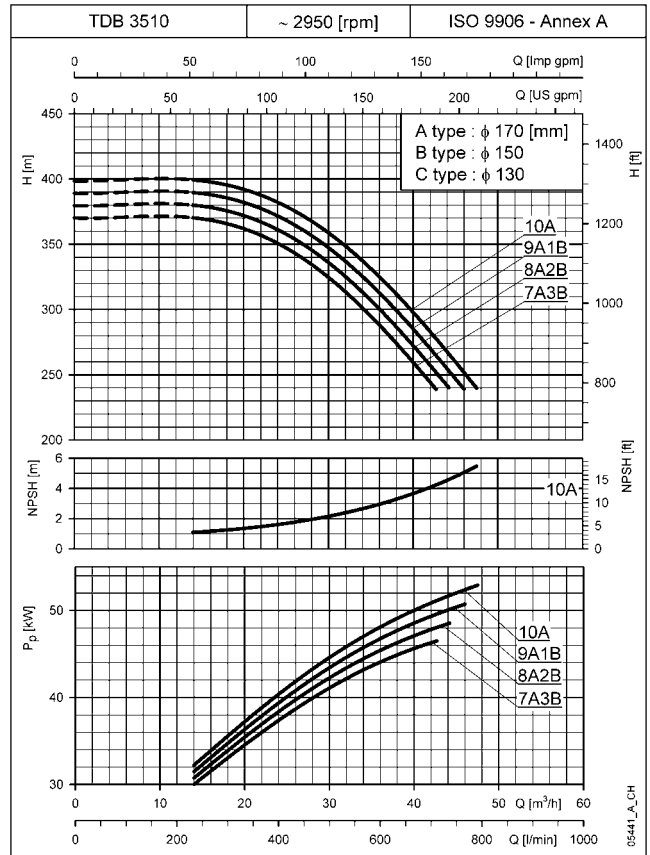
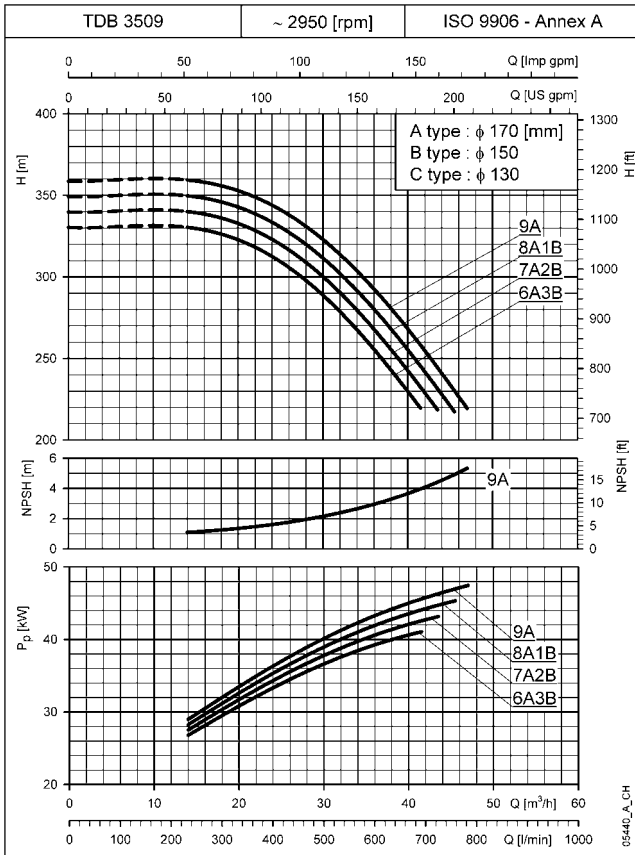

These performances are valid for liquids with density $\rho = 1,0 \text{ Kg/dm}^3$ and kinematic viscosity $\nu = 1 \text{ mm}^2/\text{sec}$.
The NPSH values are laboratory values; for practical use we suggest increasing these values by 0,5 m.

TDB58 SERIES OPERATING CHARACTERISTICS AT 50 Hz, 2 POLES

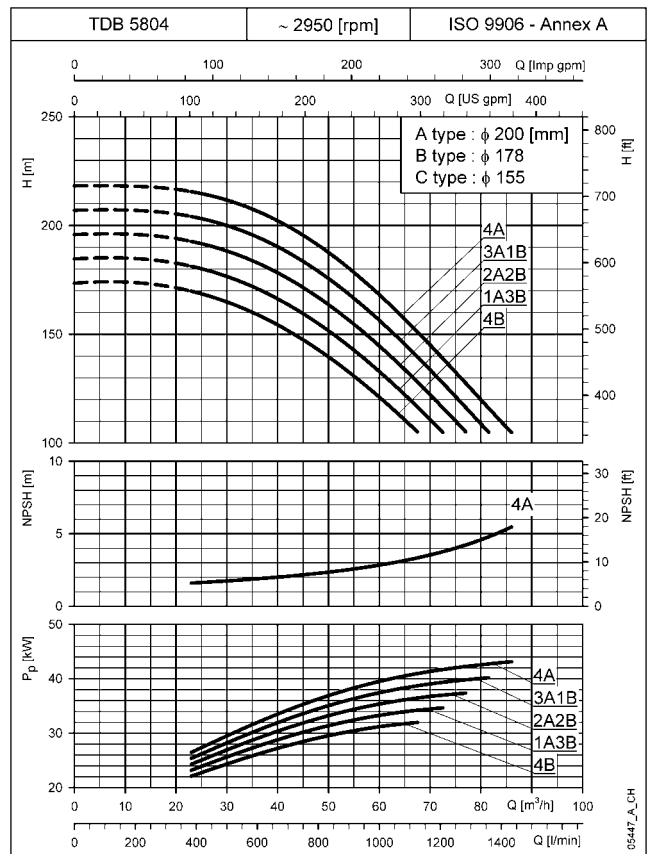
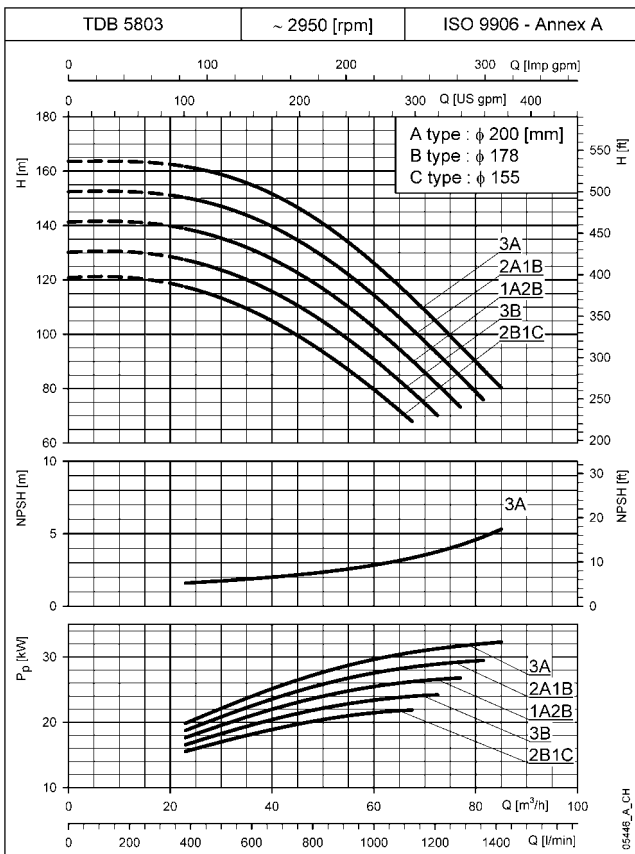
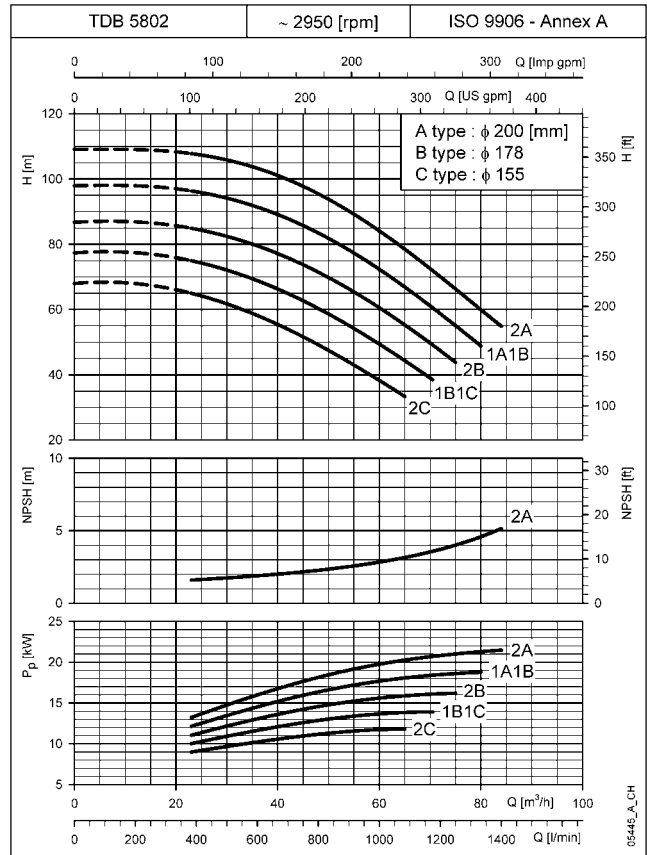
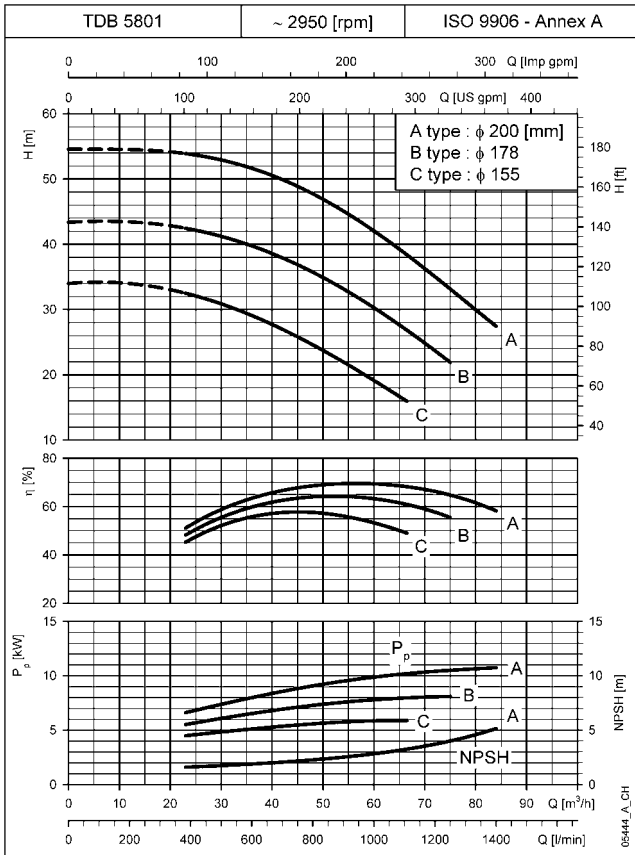

These performances are valid for liquids with density $\rho = 1,0 \text{ Kg/dm}^3$ and kinematic viscosity $\nu = 1 \text{ mm}^2/\text{sec}$.
The NPSH values are laboratory values; for practical use we suggest increasing these values by 0,5 m.

TDB58 SERIES OPERATING CHARACTERISTICS AT 50 Hz, 2 POLES

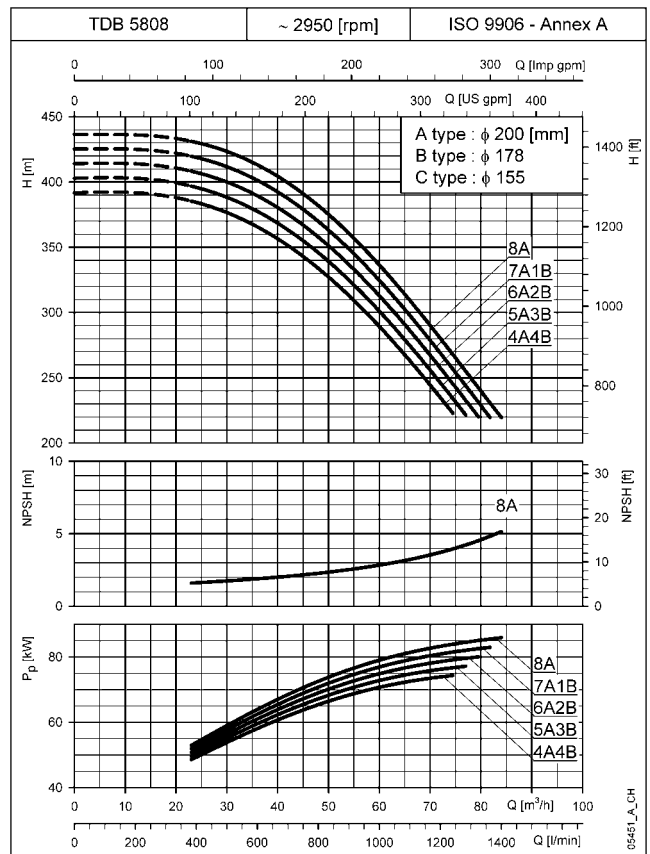
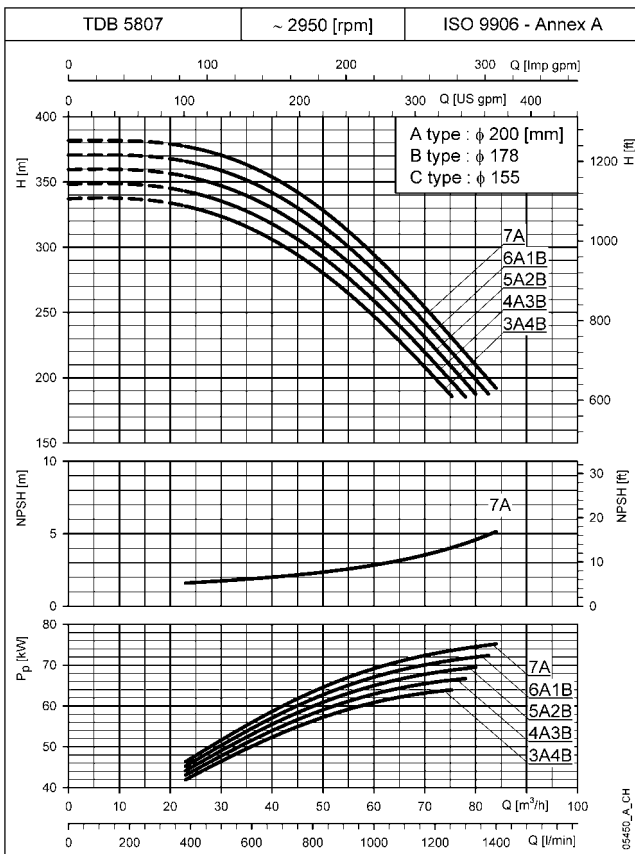
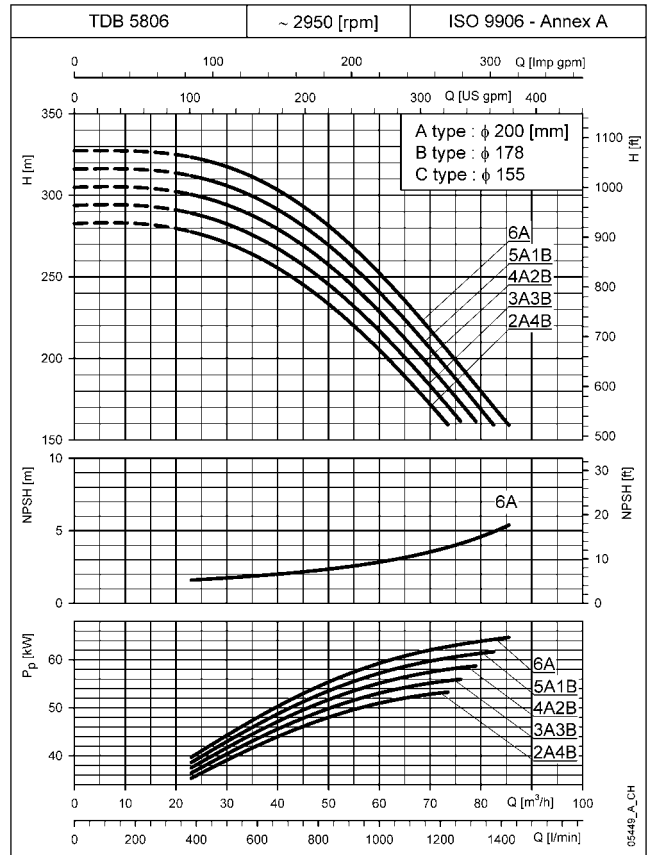
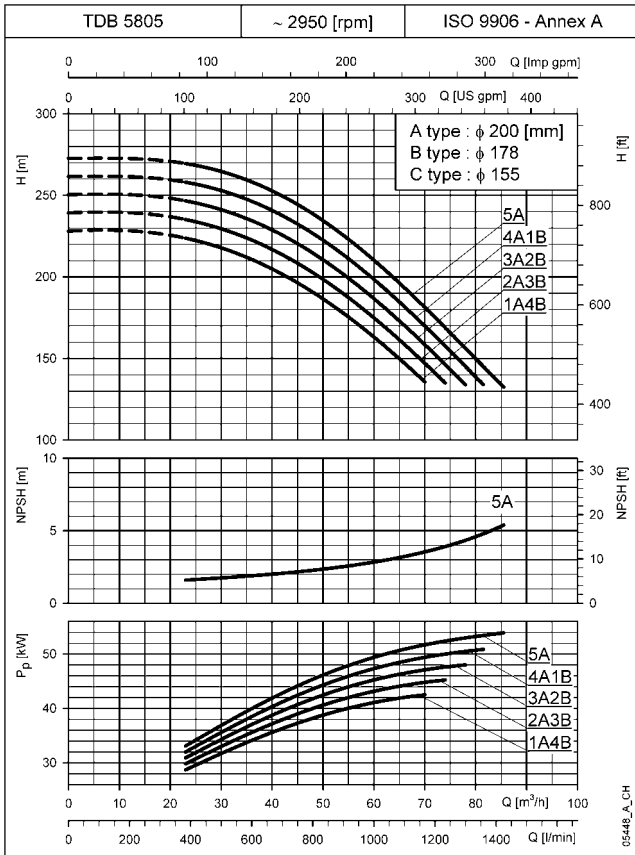

These performances are valid for liquids with density $\rho = 1,0 \text{ Kg/dm}^3$ and kinematic viscosity $\nu = 1 \text{ mm}^2/\text{sec}$.
The NPSH values are laboratory values; for practical use we suggest increasing these values by 0,5 m.

**TDB58 SERIES
OPERATING CHARACTERISTICS AT 50 Hz, 2 POLES**

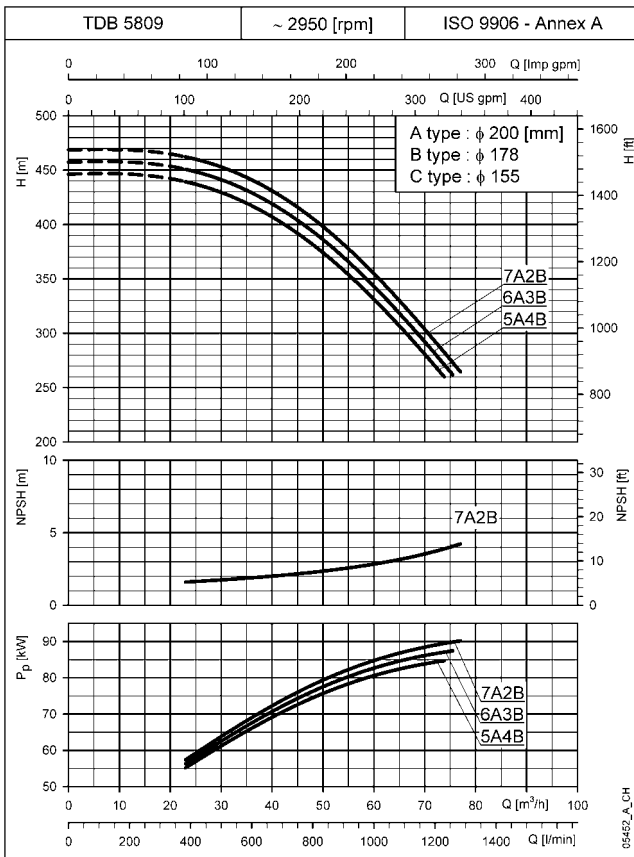

These performances are valid for liquids with density $\rho = 1,0 \text{ Kg/dm}^3$ and kinematic viscosity $\nu = 1 \text{ mm}^2/\text{sec}$.
The NPSH values are laboratory values; for practical use we suggest increasing these values by 0,5 m.

TDB78 SERIES OPERATING CHARACTERISTICS AT 50 Hz, 2 POLES

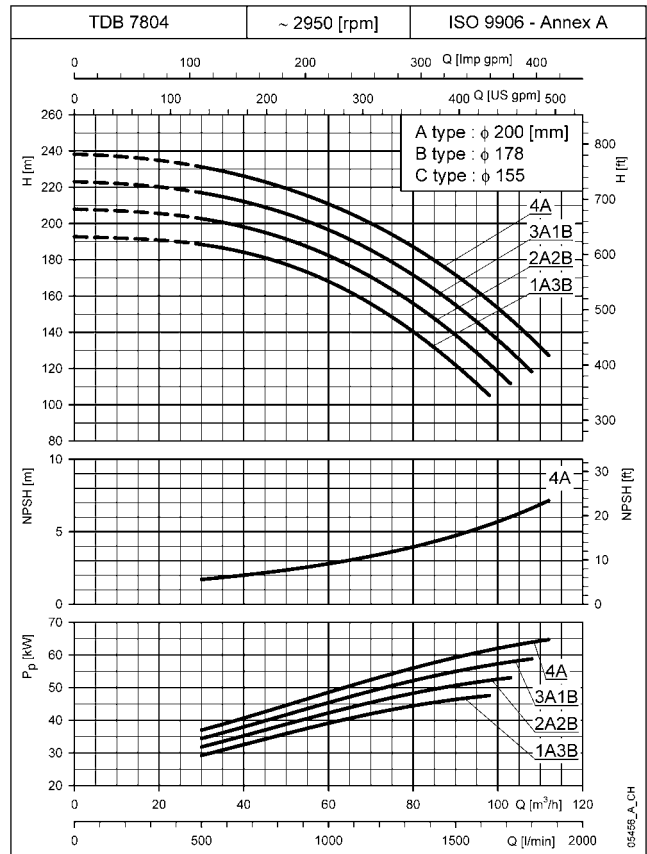
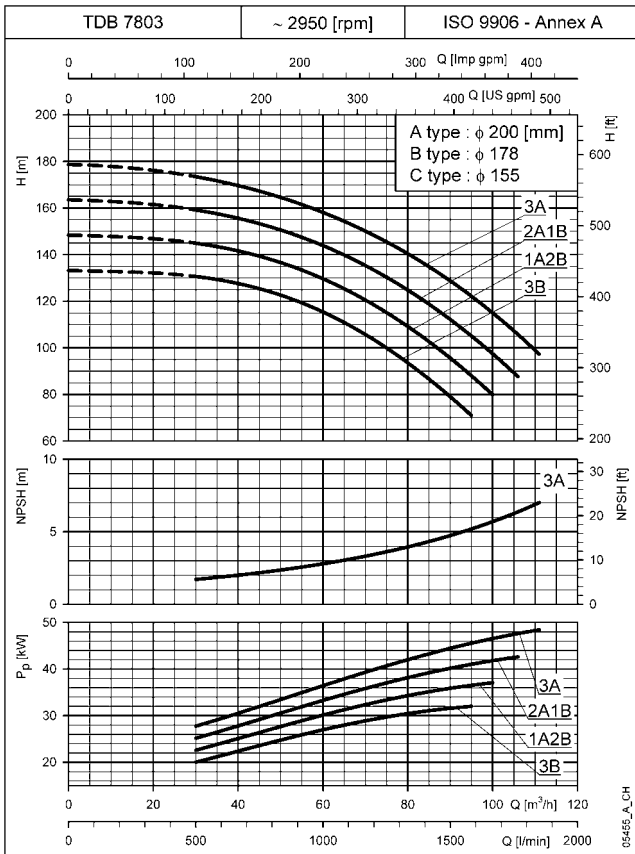
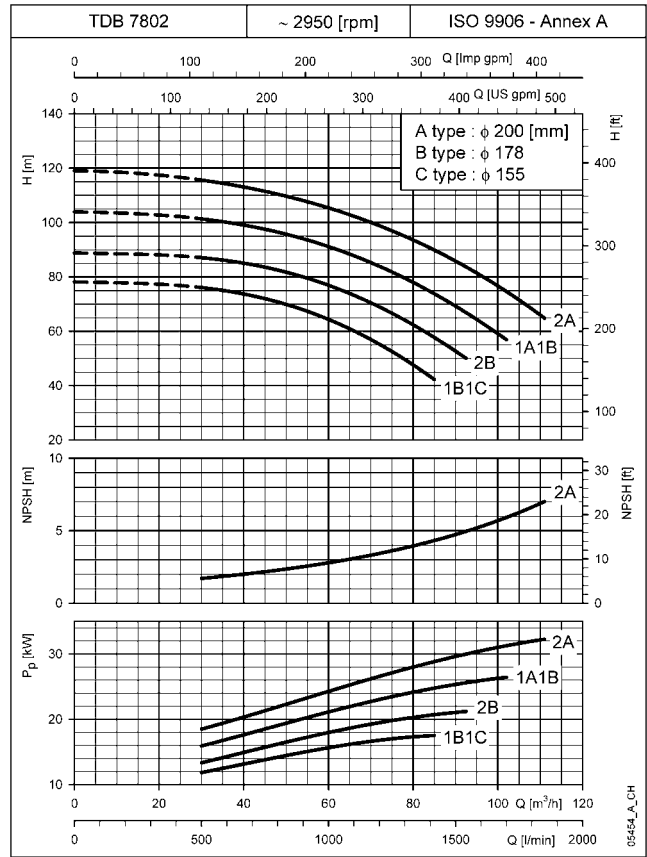
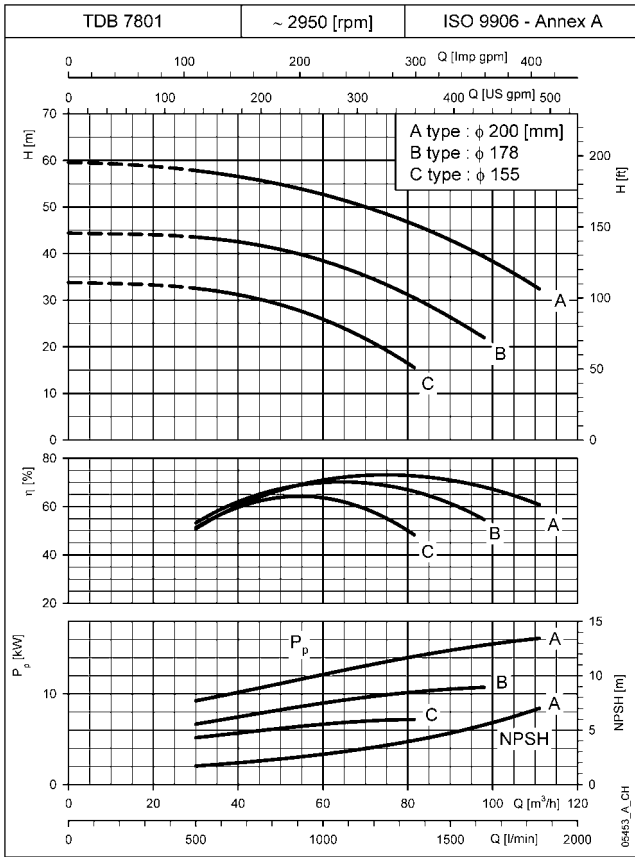

These performances are valid for liquids with density $\rho = 1,0 \text{ Kg/dm}^3$ and kinematic viscosity $\nu = 1 \text{ mm}^2/\text{sec}$.
The NPSH values are laboratory values; for practical use we suggest increasing these values by 0,5 m.

TDB78 SERIES OPERATING CHARACTERISTICS AT 50 Hz, 2 POLES

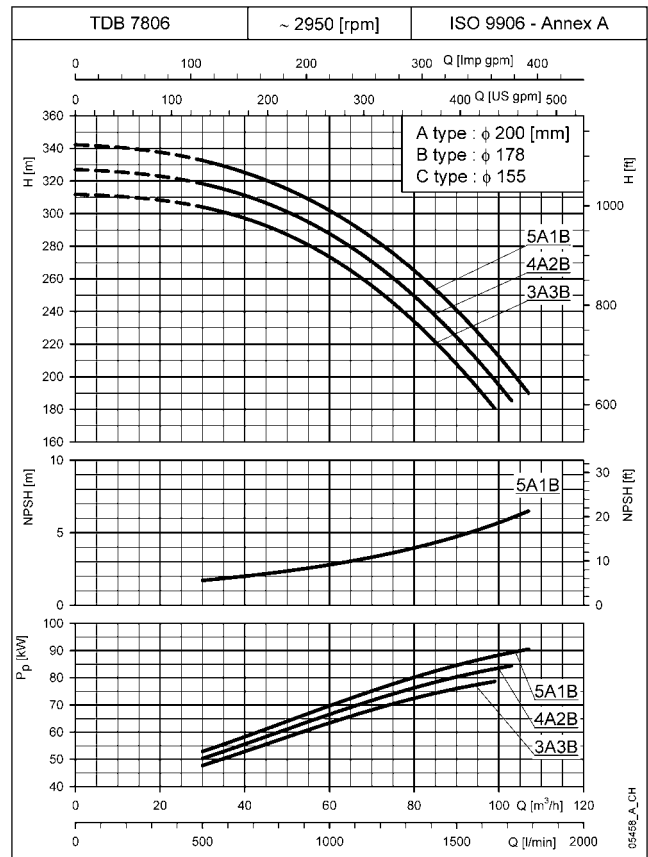
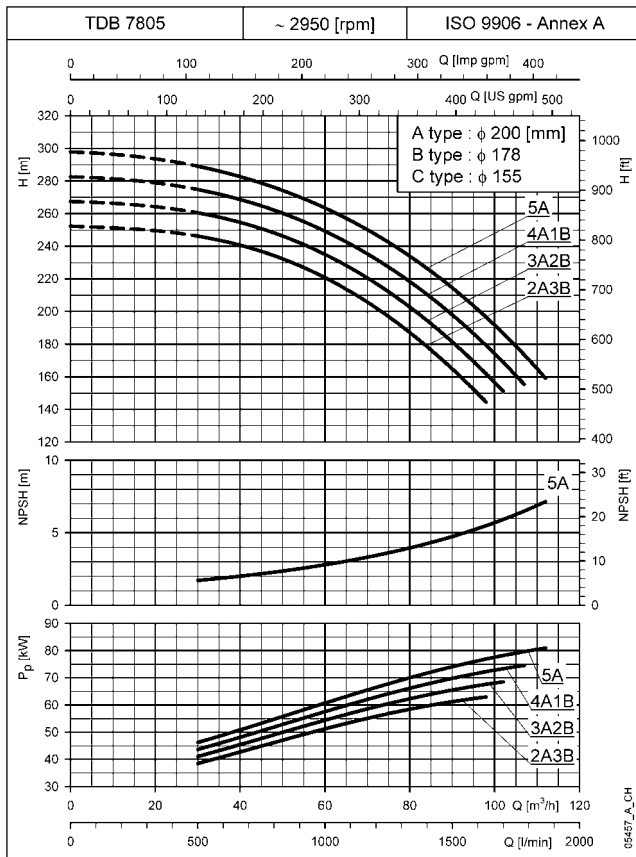

These performances are valid for liquids with density $\rho = 1,0 \text{ Kg/dm}^3$ and kinematic viscosity $\nu = 1 \text{ mm}^2/\text{sec}$.
 The NPSH values are laboratory values; for practical use we suggest increasing these values by 0,5 m.

TDB-TDV120 SERIES OPERATING CHARACTERISTICS AT 50 Hz, 2 POLES

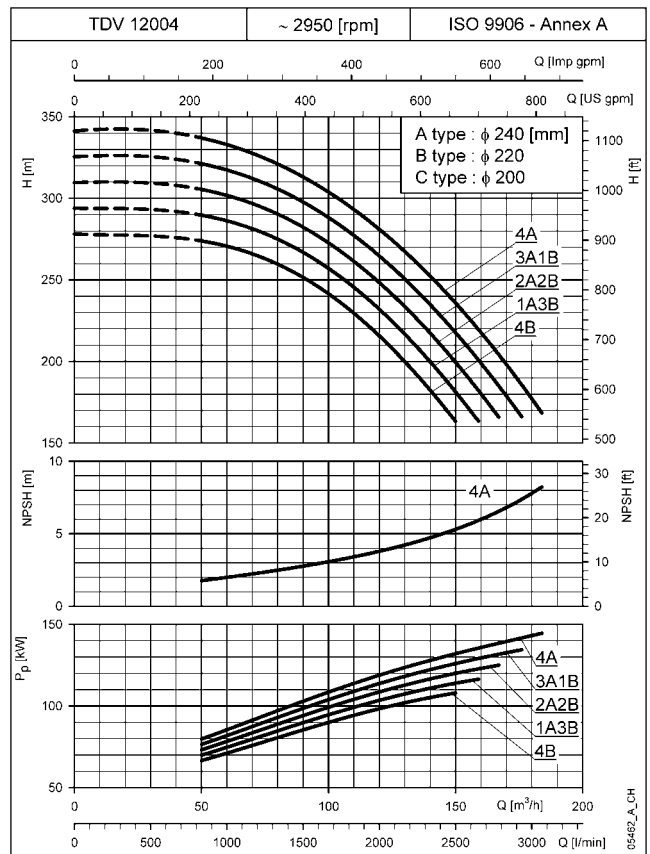
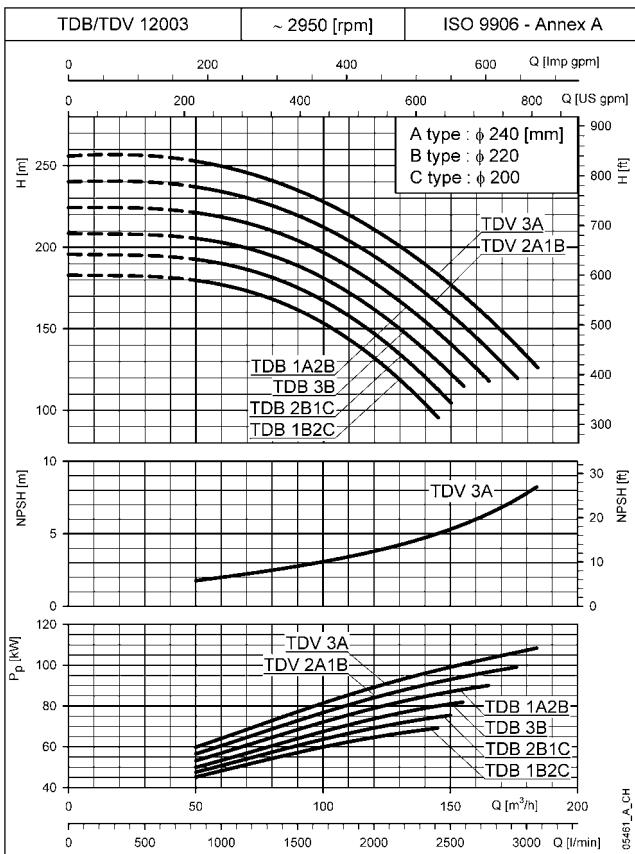
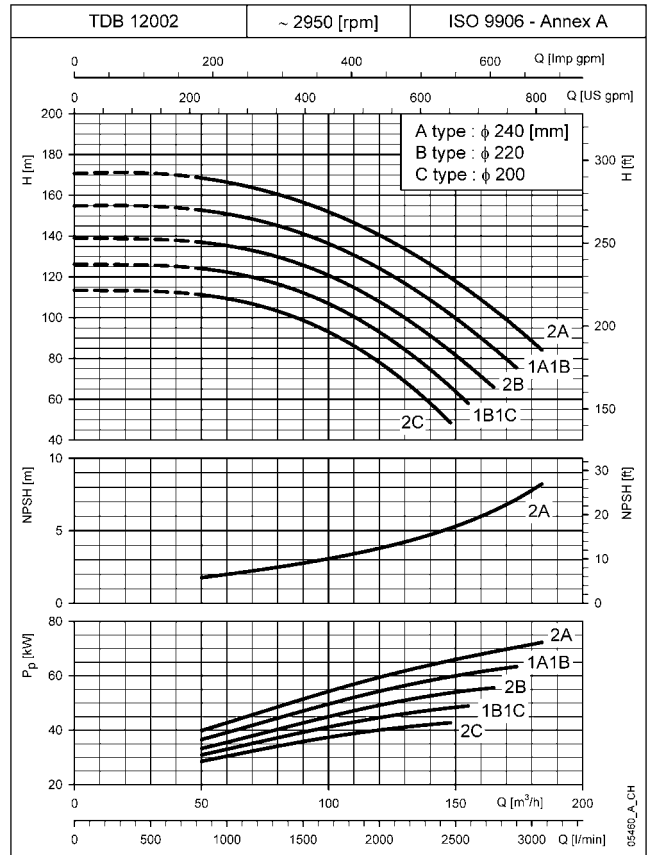
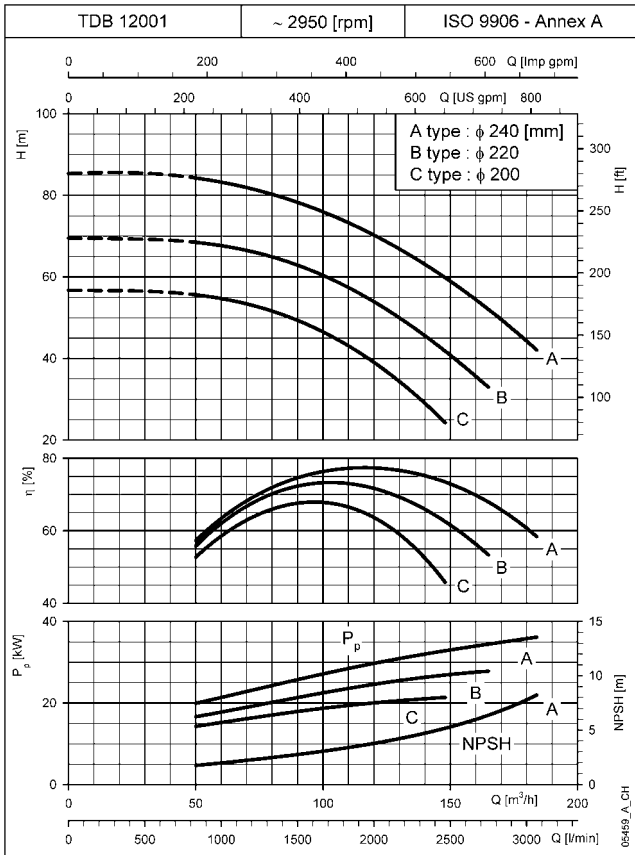

These performances are valid for liquids with density $\rho = 1,0 \text{ Kg/dm}^3$ and kinematic viscosity $\nu = 1 \text{ mm}^2/\text{sec}$.
 The NPSH values are laboratory values; for practical use we suggest increasing these values by 0,5 m.

TDB-TDV120 SERIES OPERATING CHARACTERISTICS AT 50 Hz, 2 POLES

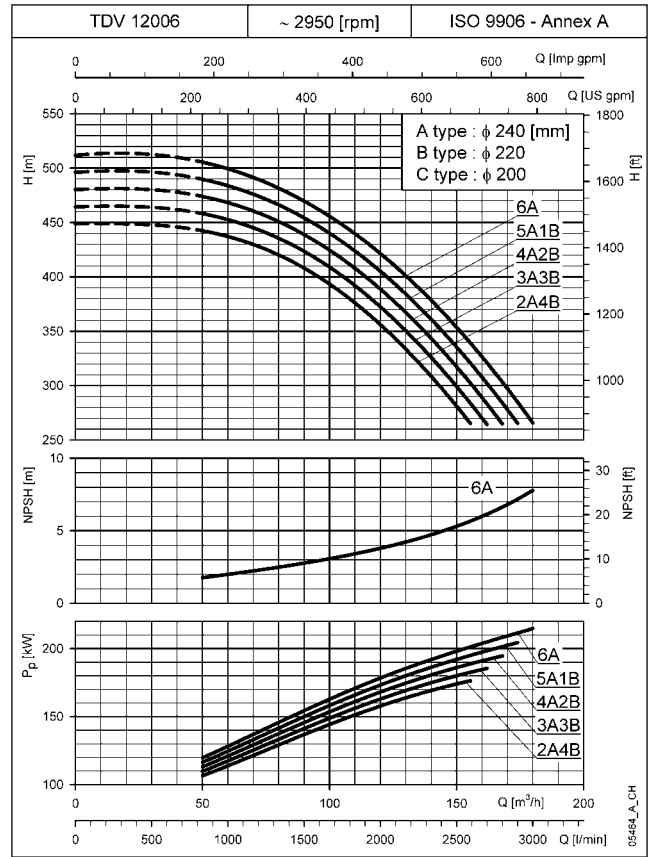
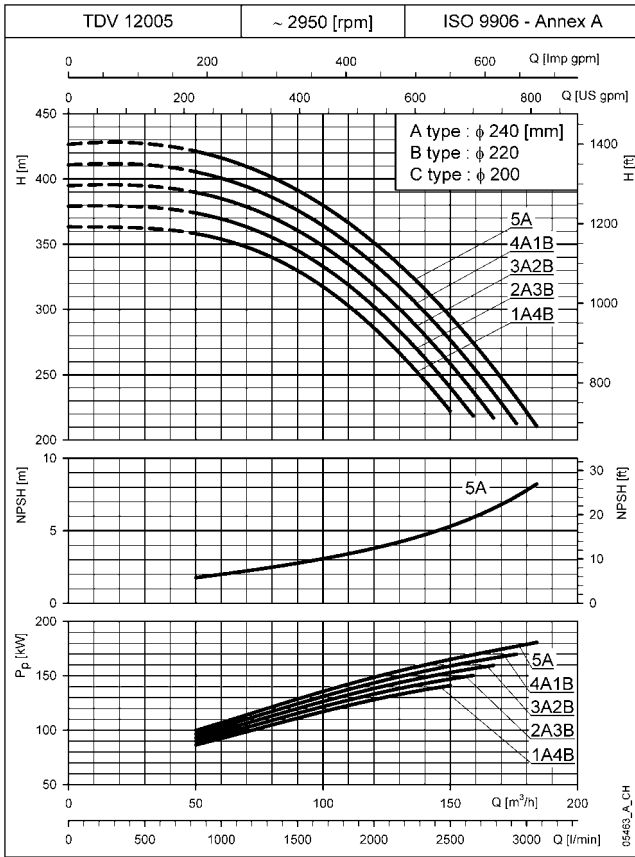

These performances are valid for liquids with density $\rho = 1,0 \text{ Kg/dm}^3$ and kinematic viscosity $\nu = 1 \text{ mm}^2/\text{sec}$.
The NPSH values are laboratory values; for practical use we suggest increasing these values by 0,5 m.

TDB-TDV170 SERIES OPERATING CHARACTERISTICS AT 50 Hz, 2 POLES

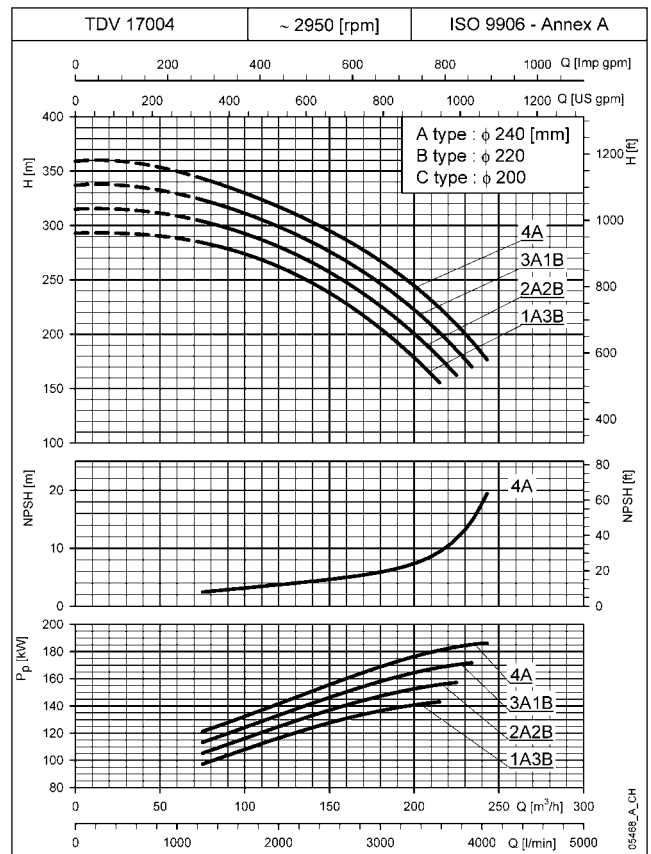
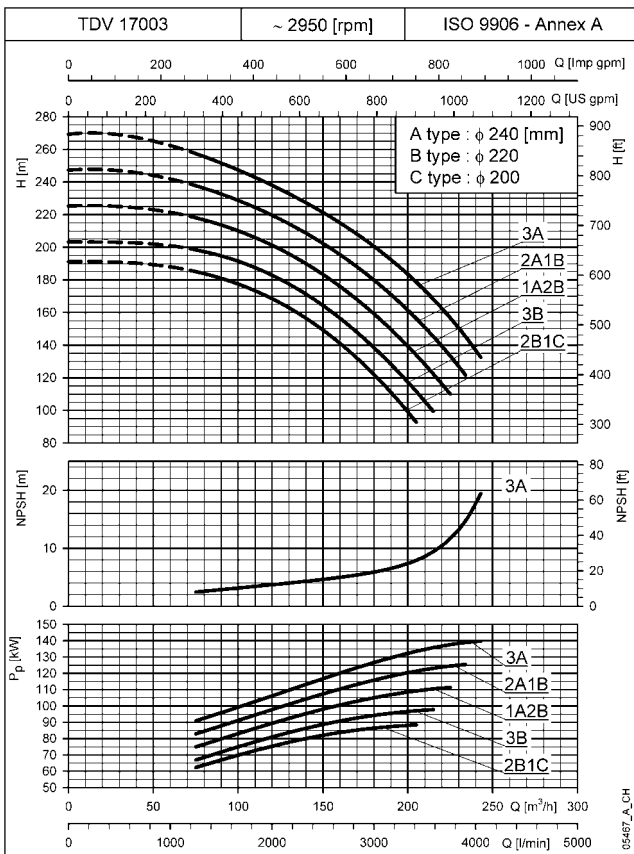
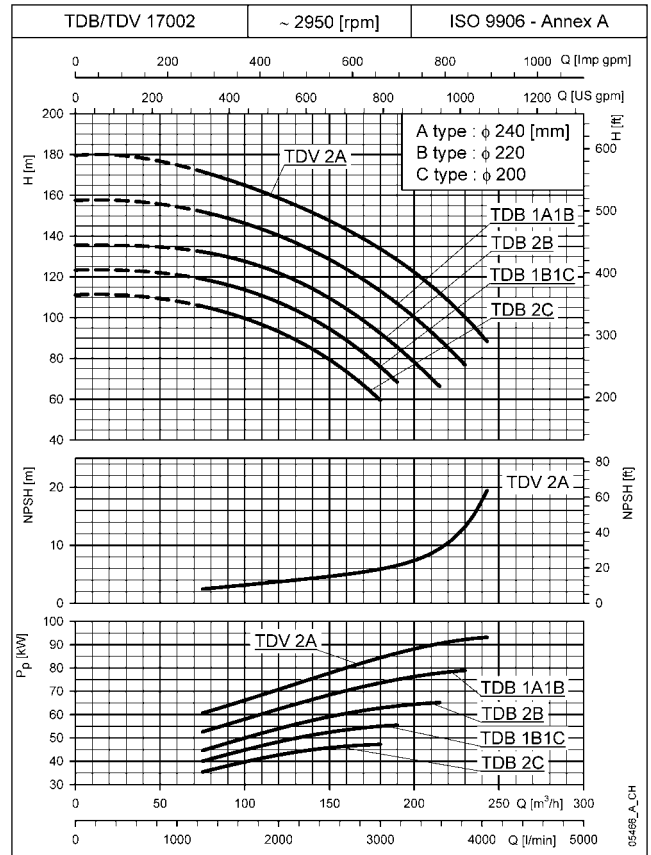
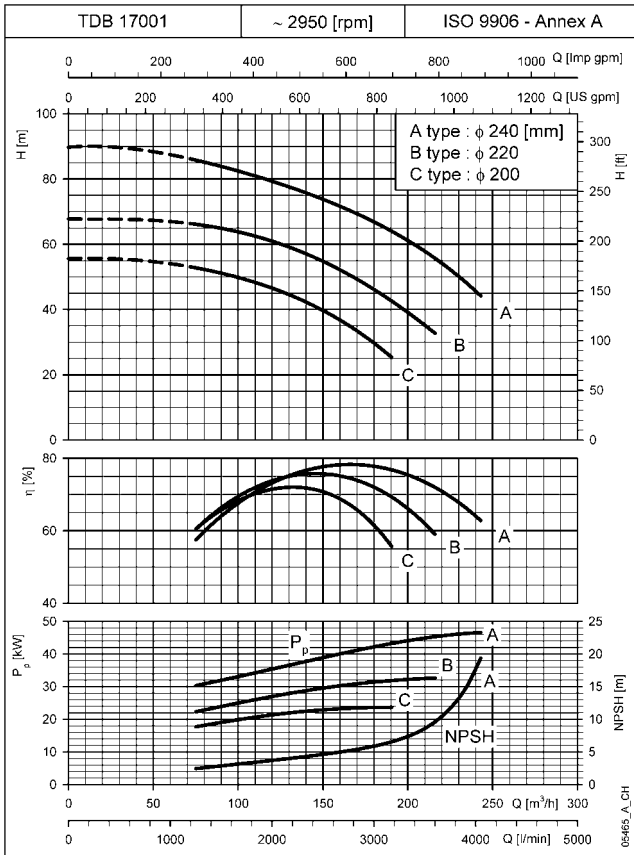

These performances are valid for liquids with density $\rho = 1,0 \text{ Kg/dm}^3$ and kinematic viscosity $\nu = 1 \text{ mm}^2/\text{sec}$.
The NPSH values are laboratory values; for practical use we suggest increasing these values by 0,5 m.

**TDV170 SERIES
OPERATING CHARACTERISTICS AT 50 Hz, 2 POLES**

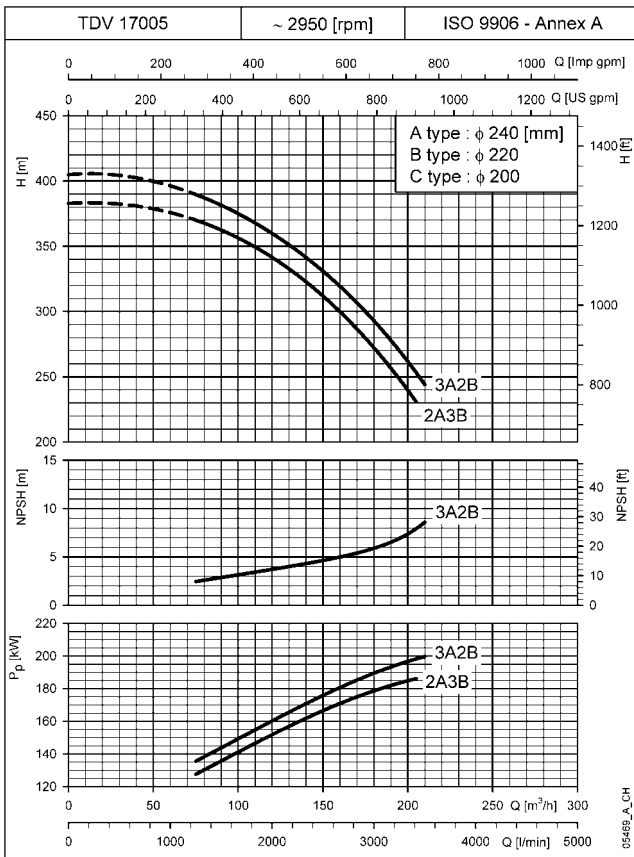

These performances are valid for liquids with density $\rho = 1,0 \text{ Kg/dm}^3$ and kinematic viscosity $\nu = 1 \text{ mm}^2/\text{sec}$.
The NPSH values are laboratory values; for practical use we suggest increasing these values by 0,5 m.

TDV220 SERIES OPERATING CHARACTERISTICS AT 50 Hz, 2 POLES

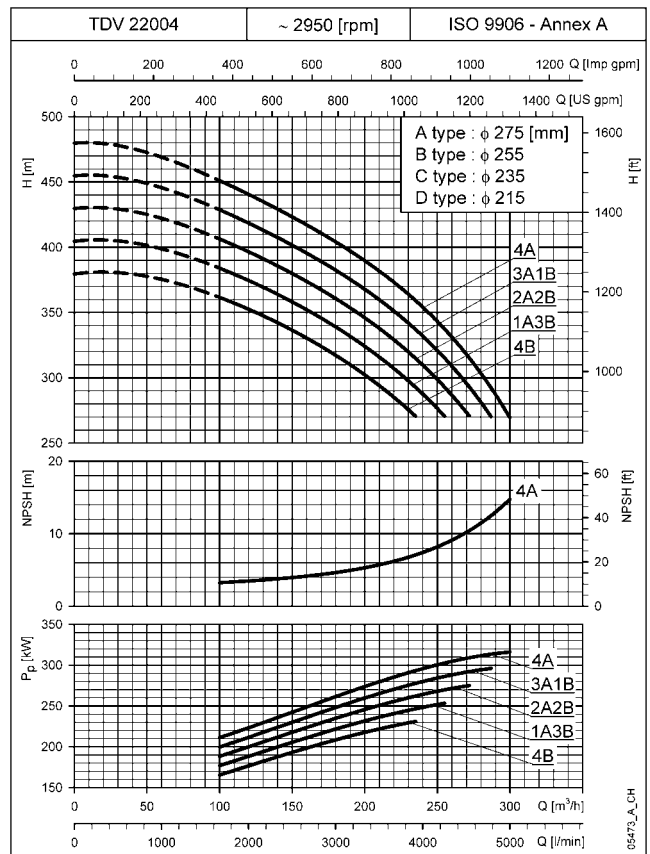
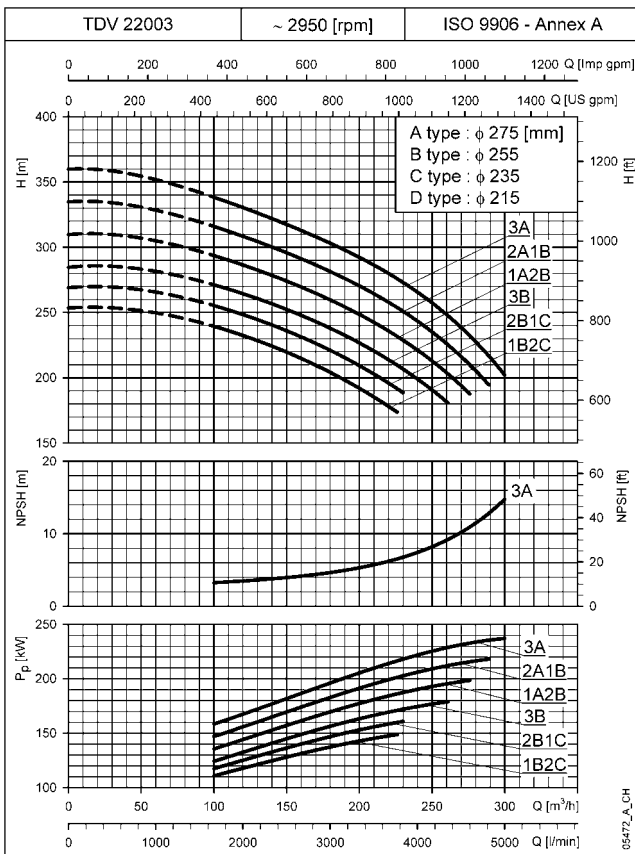
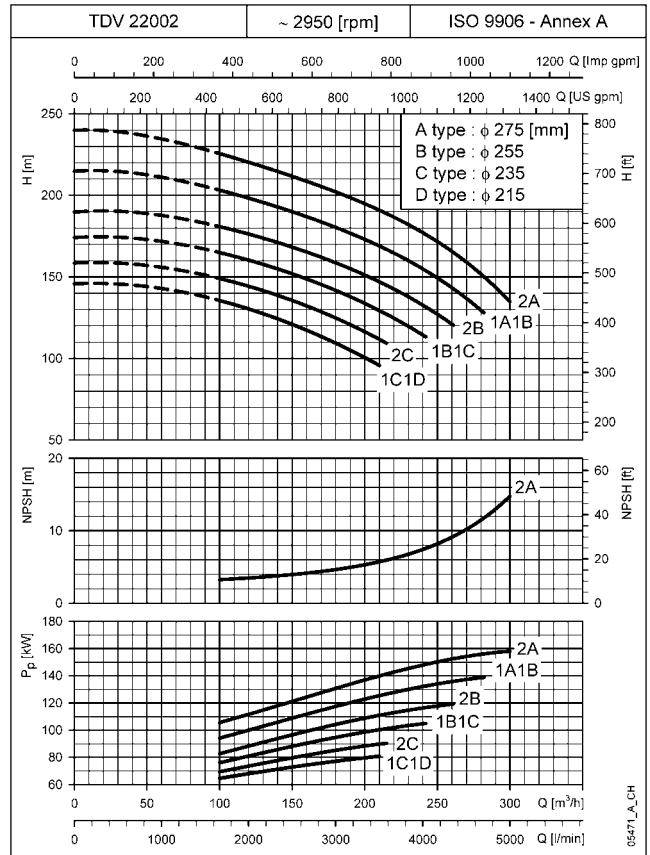
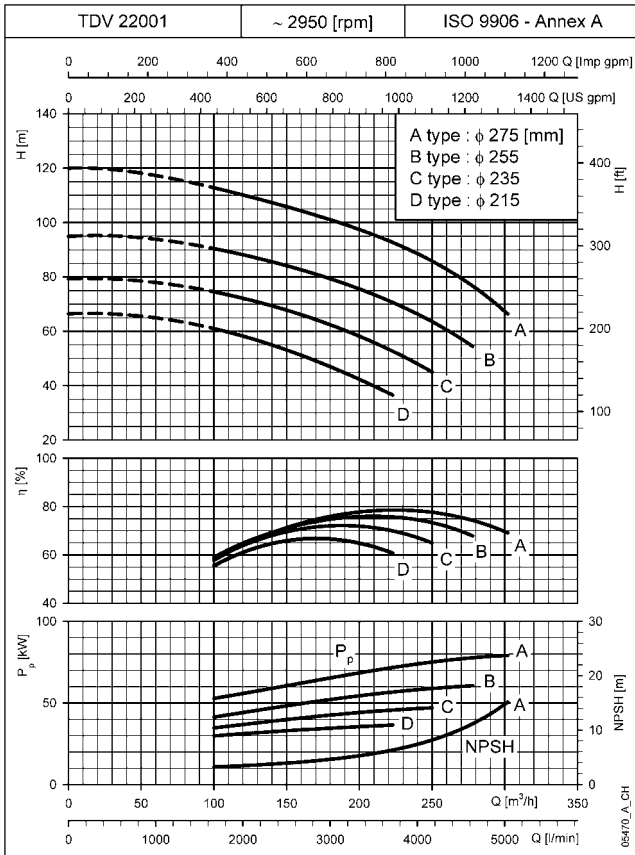

These performances are valid for liquids with density $\rho = 1,0 \text{ Kg/dm}^3$ and kinematic viscosity $\nu = 1 \text{ mm}^2/\text{sec}$.
The NPSH values are laboratory values; for practical use we suggest increasing these values by 0,5 m.

**TDV220 SERIES
OPERATING CHARACTERISTICS AT 50 Hz, 2 POLES**

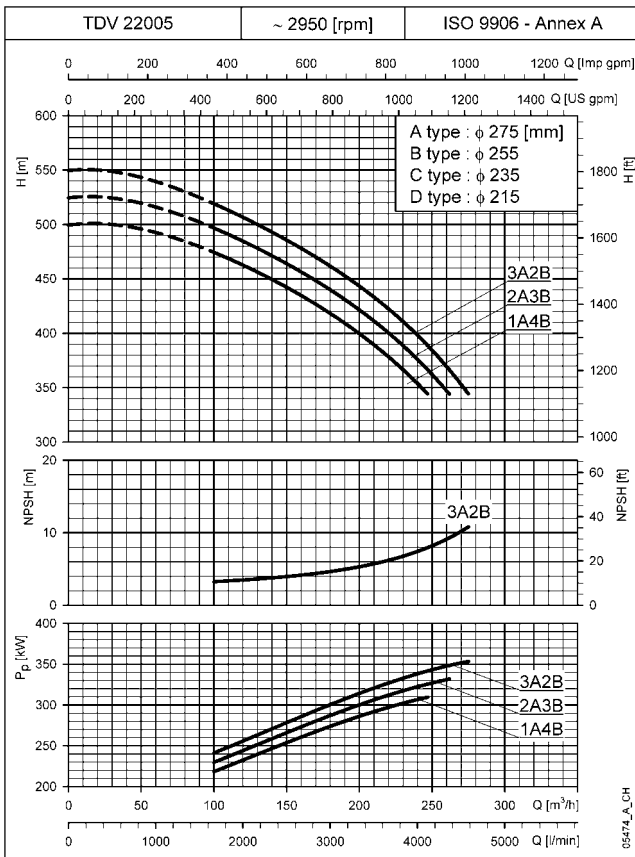

These performances are valid for liquids with density $\rho = 1,0 \text{ Kg/dm}^3$ and kinematic viscosity $\nu = 1 \text{ mm}^2/\text{sec}$.
 The NPSH values are laboratory values; for practical use we suggest increasing these values by 0,5 m.

TDV280 SERIES OPERATING CHARACTERISTICS AT 50 Hz, 2 POLES

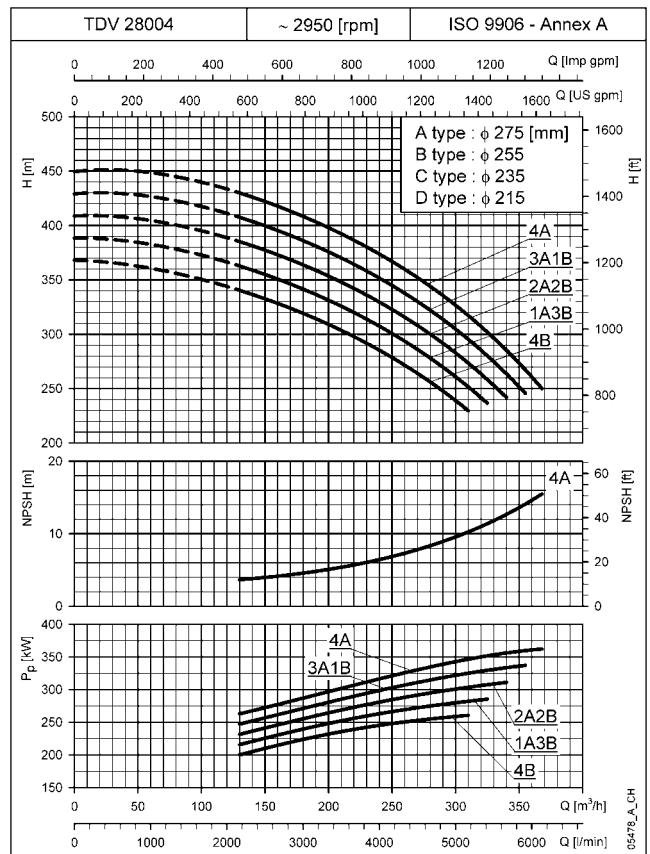
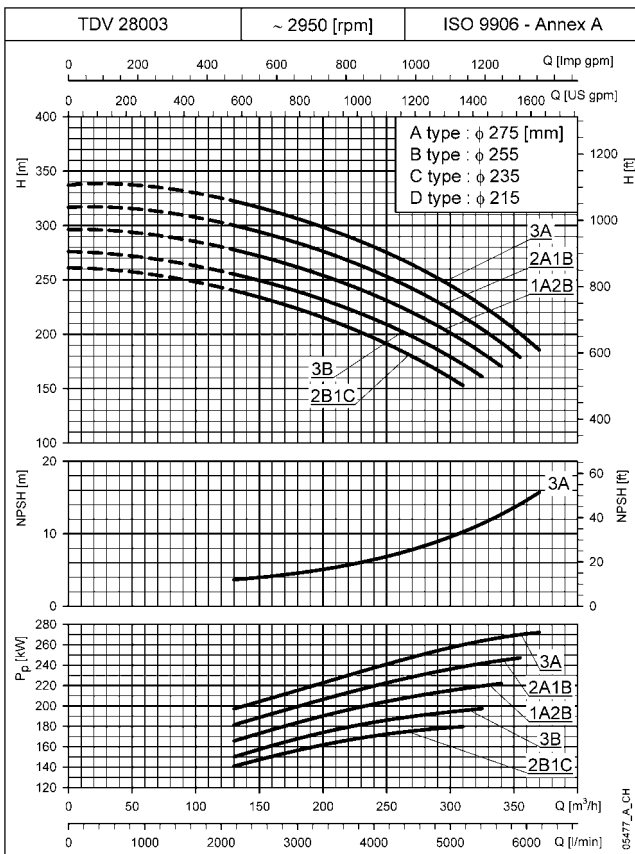
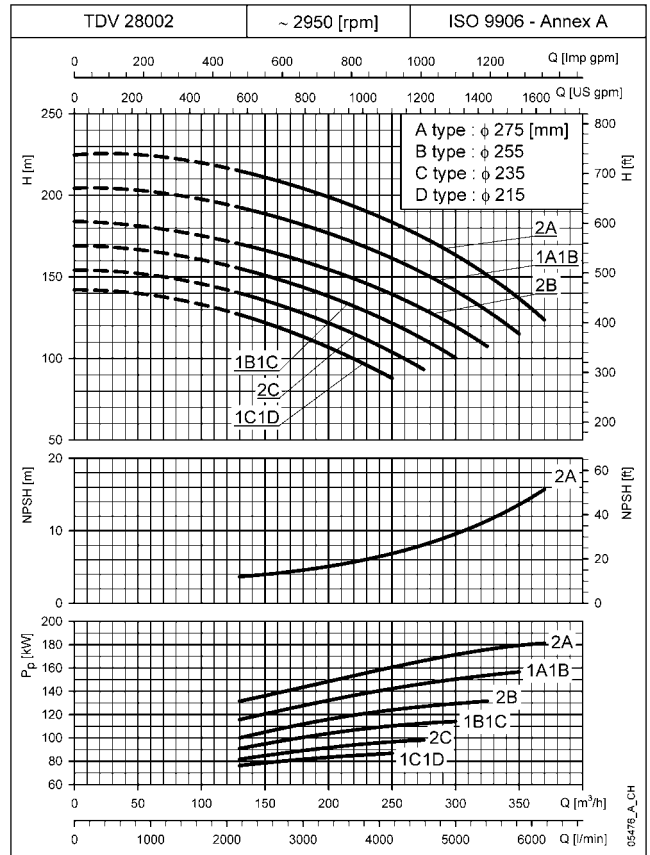
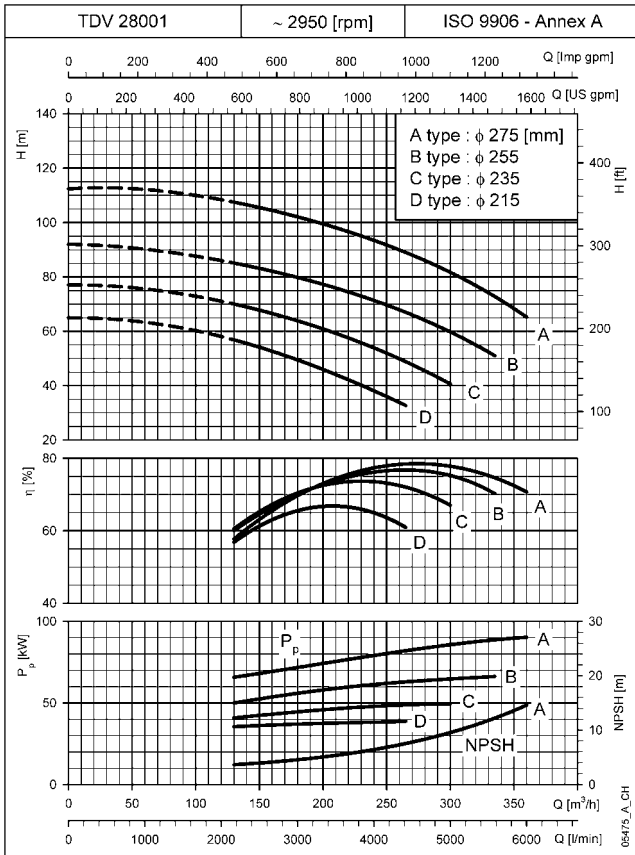

These performances are valid for liquids with density $\rho = 1,0 \text{ Kg/dm}^3$ and kinematic viscosity $\nu = 1 \text{ mm}^2/\text{sec}$.
The NPSH values are laboratory values; for practical use we suggest increasing these values by 0,5 m.

**TDV280 SERIES
OPERATING CHARACTERISTICS AT 50 Hz, 2 POLES**

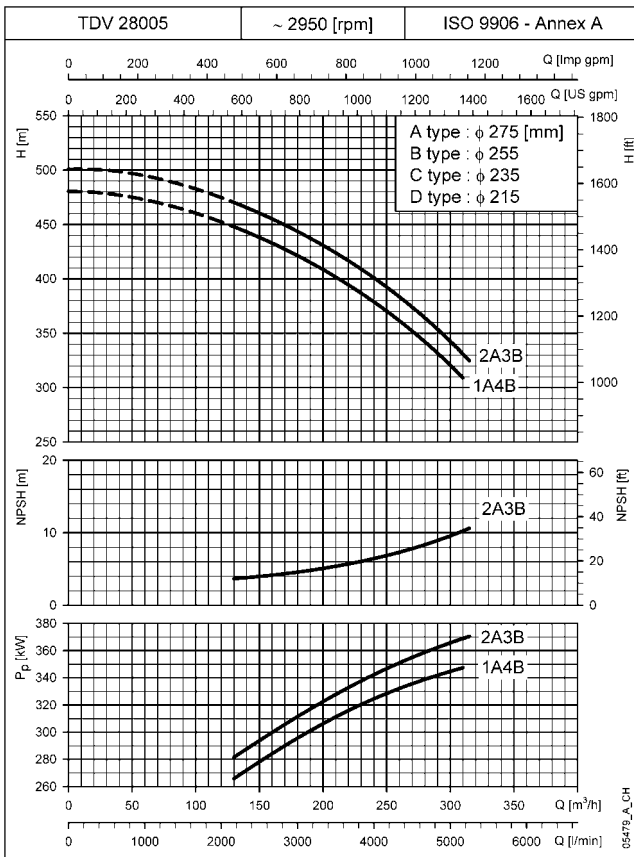

These performances are valid for liquids with density $\rho = 1,0 \text{ Kg/dm}^3$ and kinematic viscosity $\nu = 1 \text{ mm}^2/\text{sec}$.
The NPSH values are laboratory values; for practical use we suggest increasing these values by 0,5 m.

TDB22..4 SERIES OPERATING CHARACTERISTICS AT 50 Hz, 4 POLES

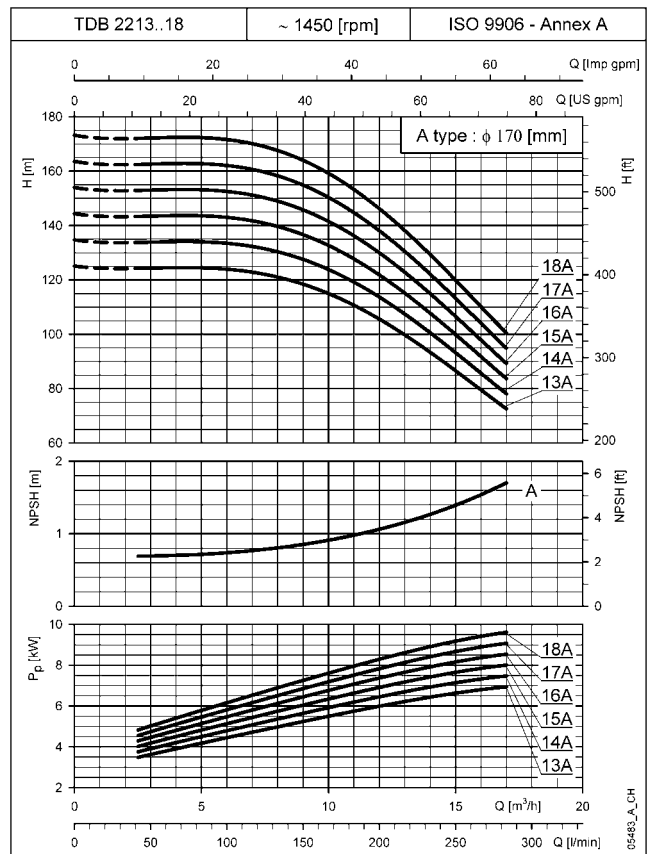
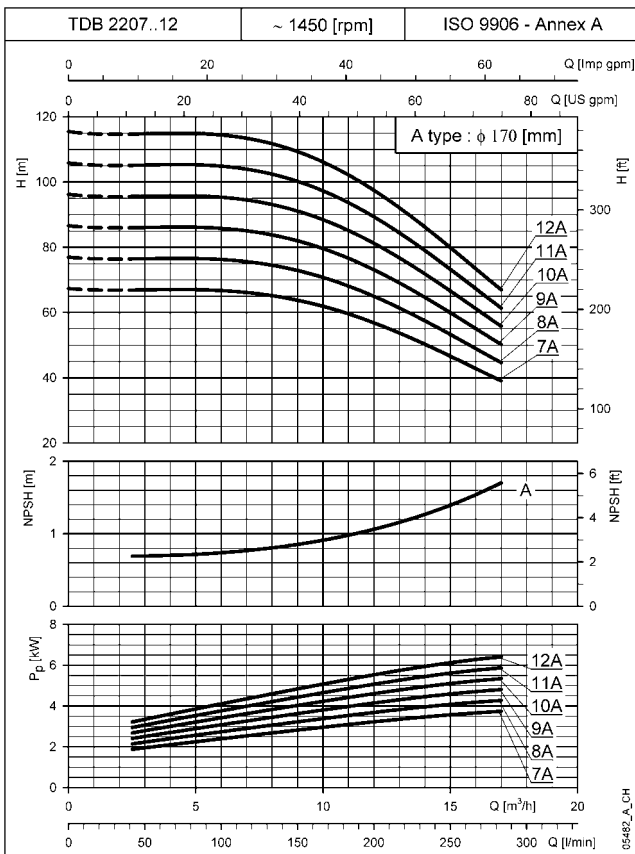
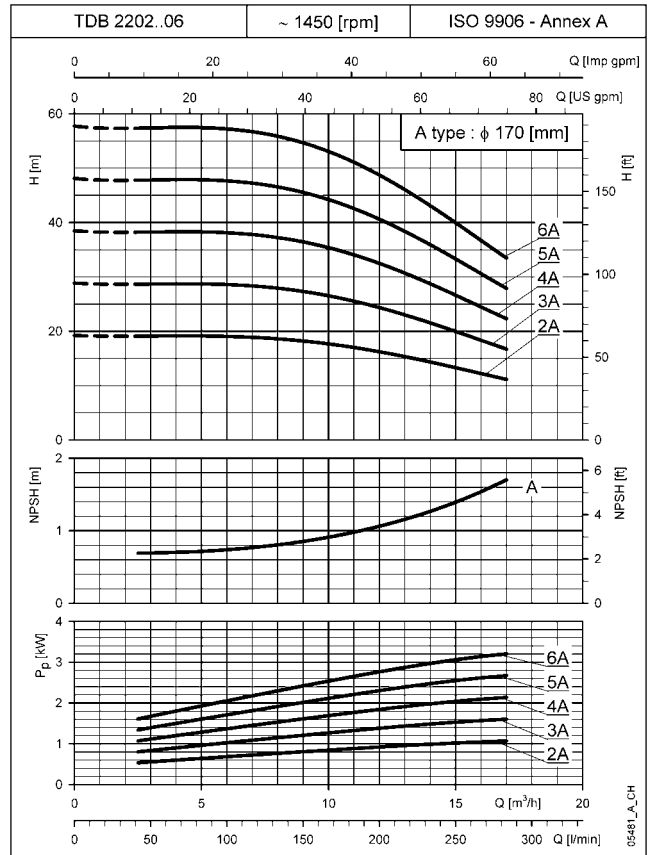
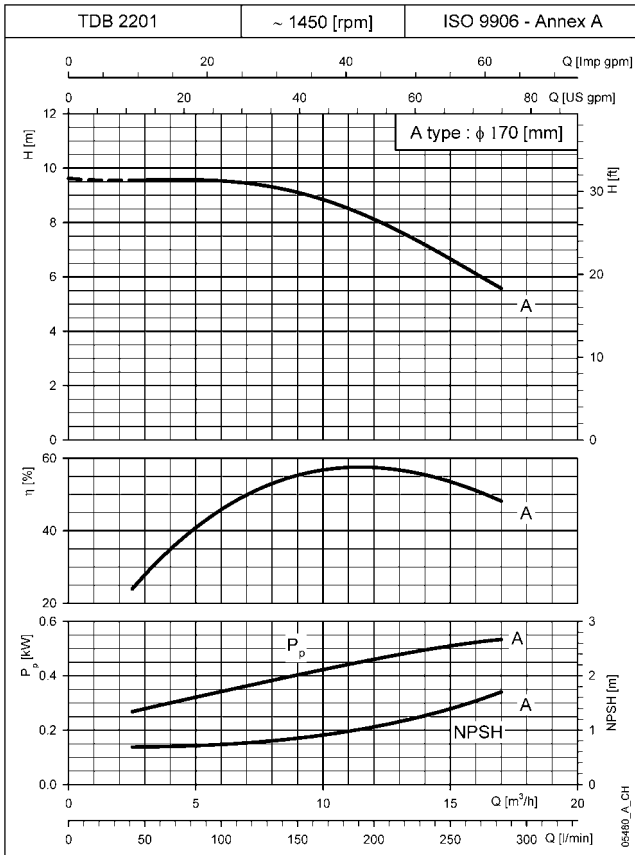

These performances are valid for liquids with density $\rho = 1,0 \text{ Kg/dm}^3$ and kinematic viscosity $\nu = 1 \text{ mm}^2/\text{sec}$.
The NPSH values are laboratory values; for practical use we suggest increasing these values by 0,5 m.

TDB58..4 SERIES OPERATING CHARACTERISTICS AT 50 Hz, 4 POLES

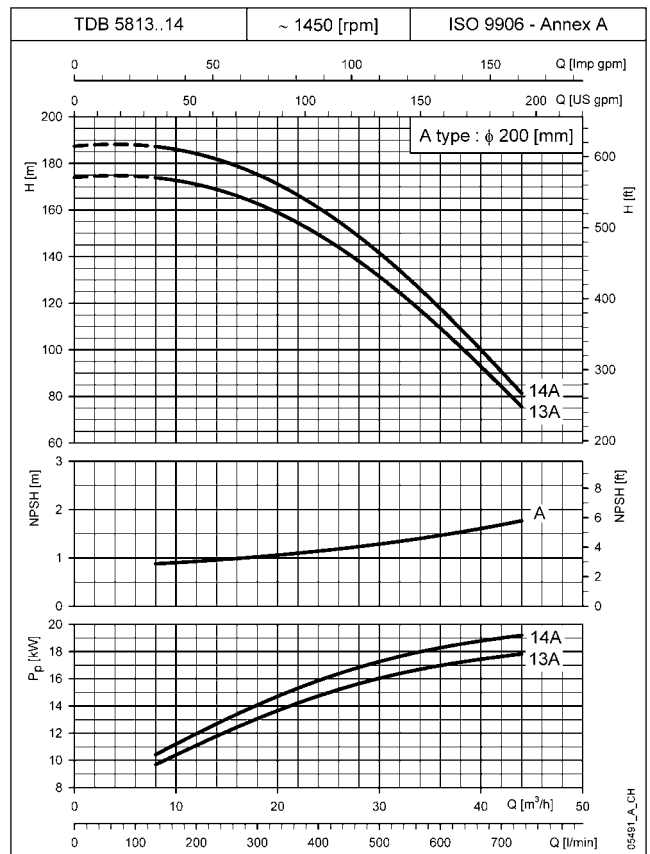
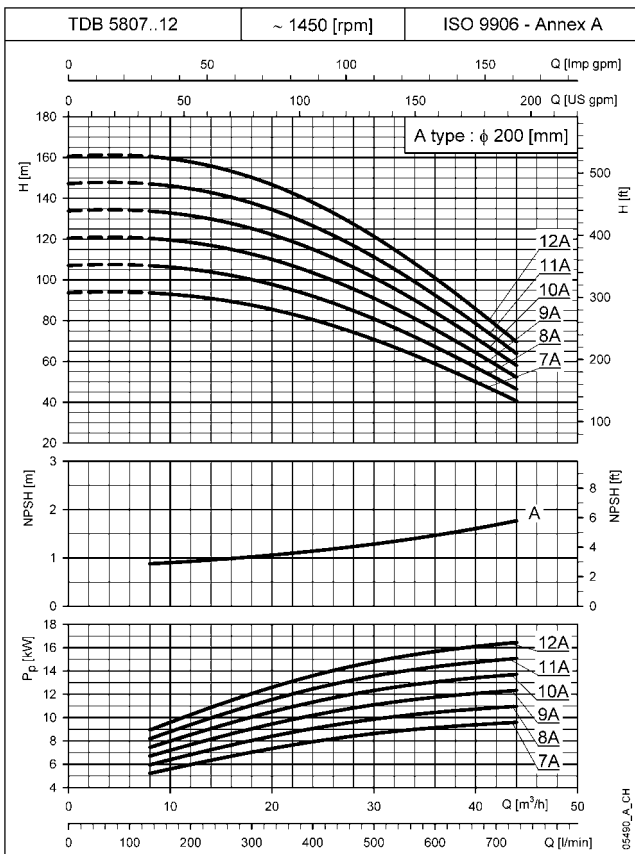
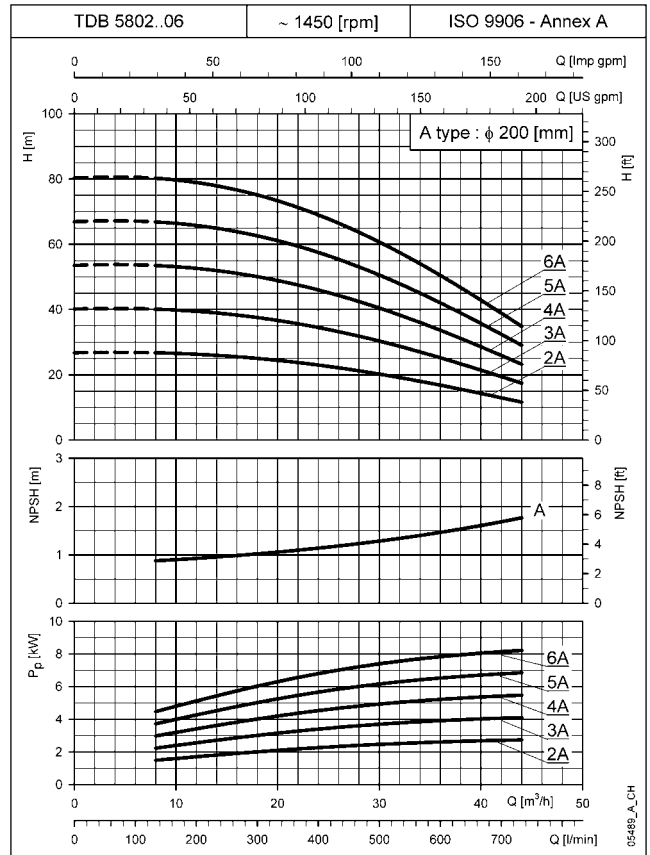
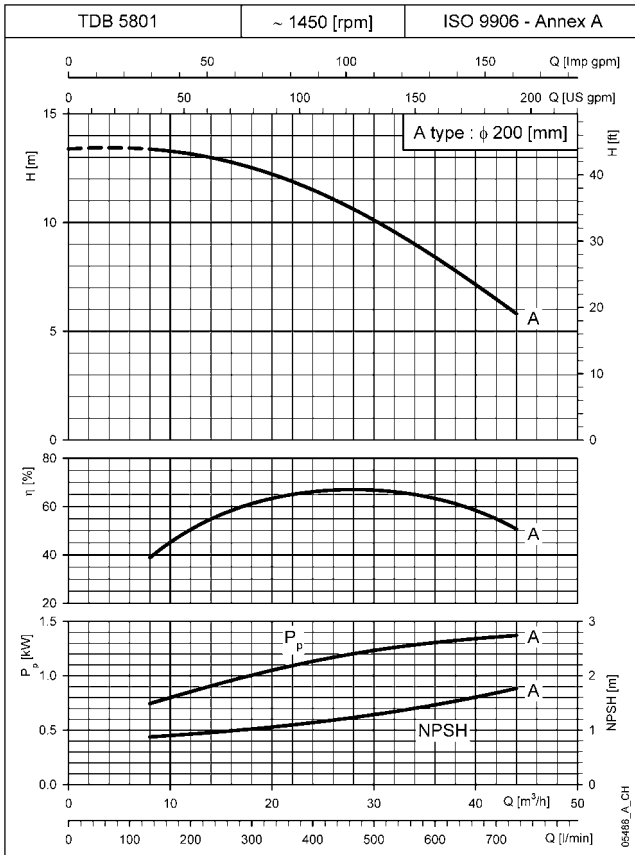

These performances are valid for liquids with density $\rho = 1,0 \text{ Kg/dm}^3$ and kinematic viscosity $\nu = 1 \text{ mm}^2/\text{sec}$.
The NPSH values are laboratory values; for practical use we suggest increasing these values by 0,5 m.

TDB78..4 SERIES OPERATING CHARACTERISTICS AT 50 Hz, 4 POLES

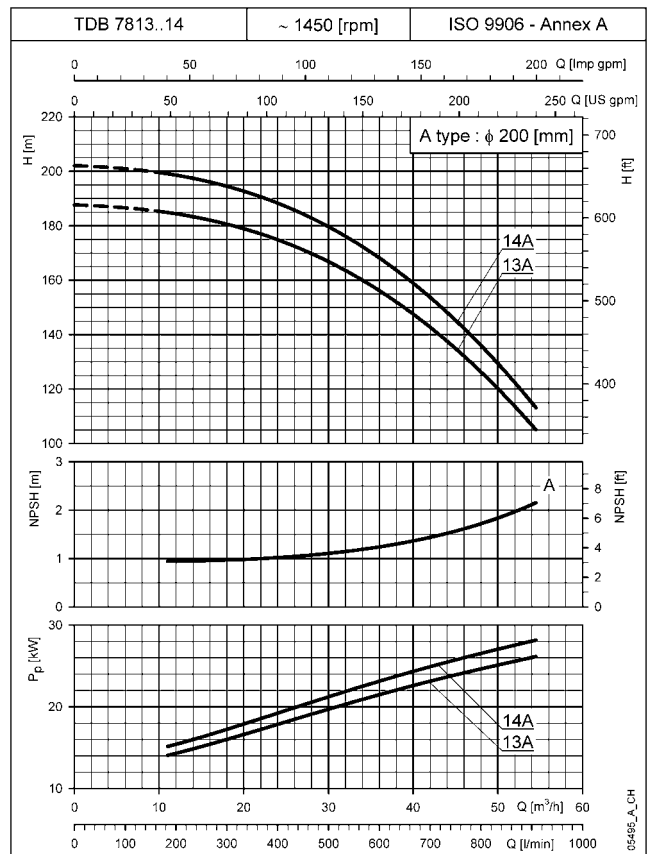
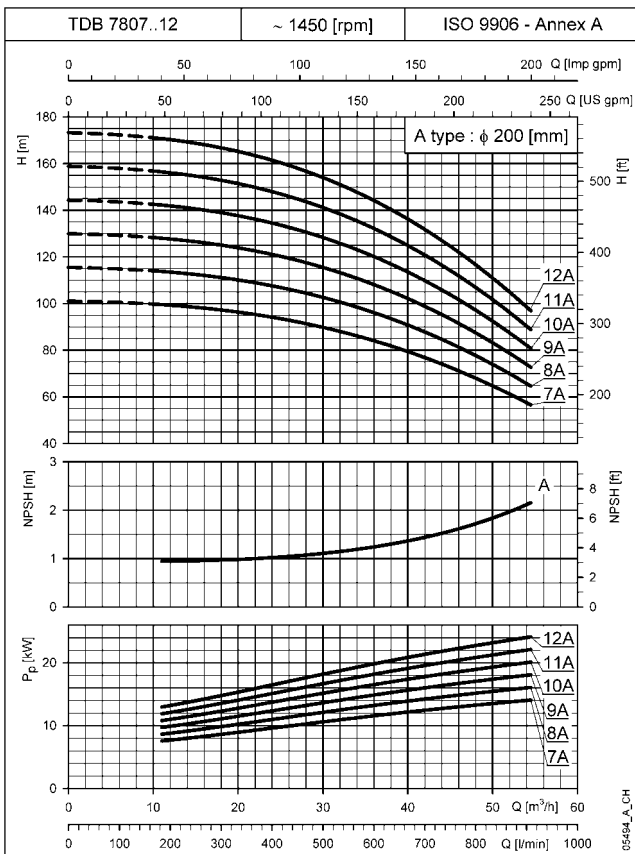
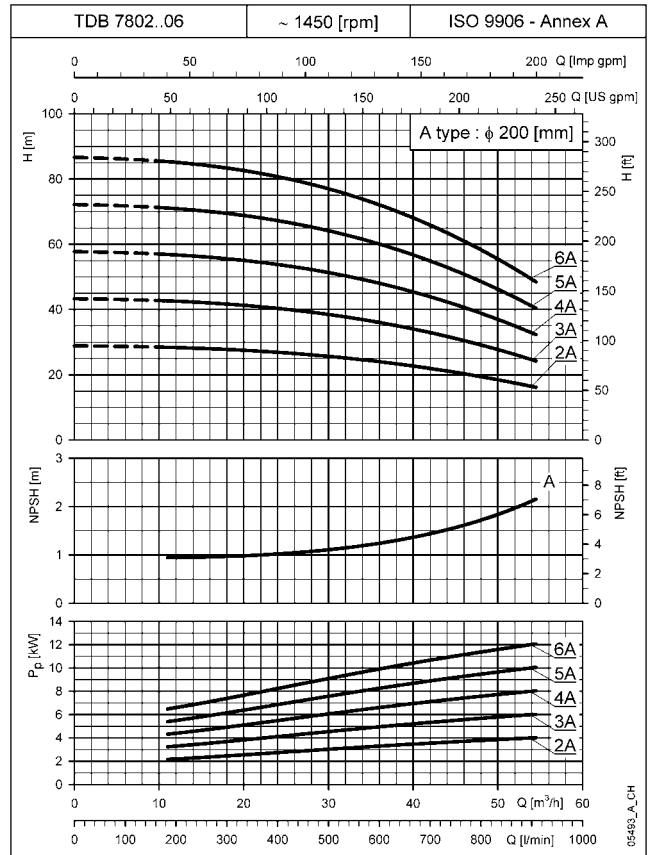
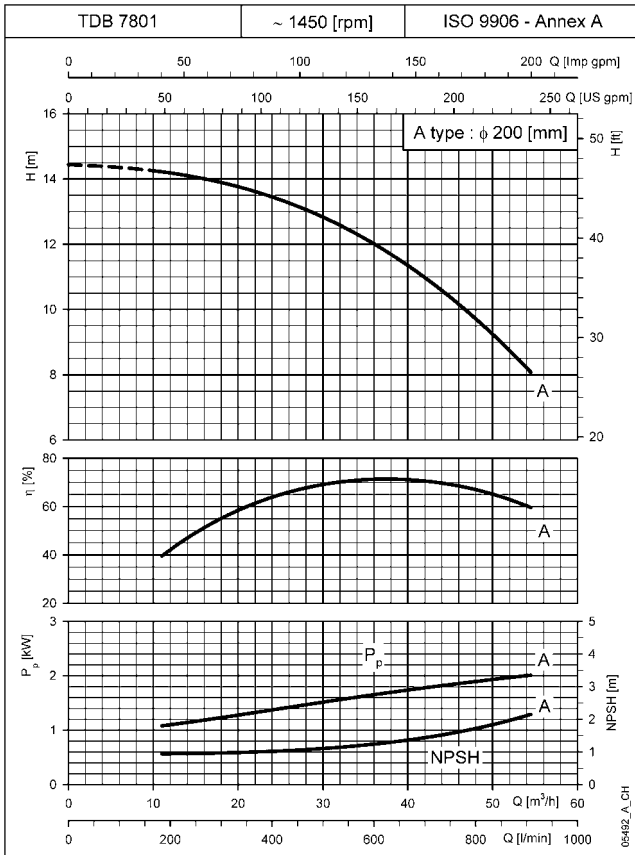

These performances are valid for liquids with density $\rho = 1,0 \text{ Kg/dm}^3$ and kinematic viscosity $\nu = 1 \text{ mm}^2/\text{sec}$.
The NPSH values are laboratory values; for practical use we suggest increasing these values by 0,5 m.

TDB120..4 SERIES OPERATING CHARACTERISTICS AT 50 Hz, 4 POLES

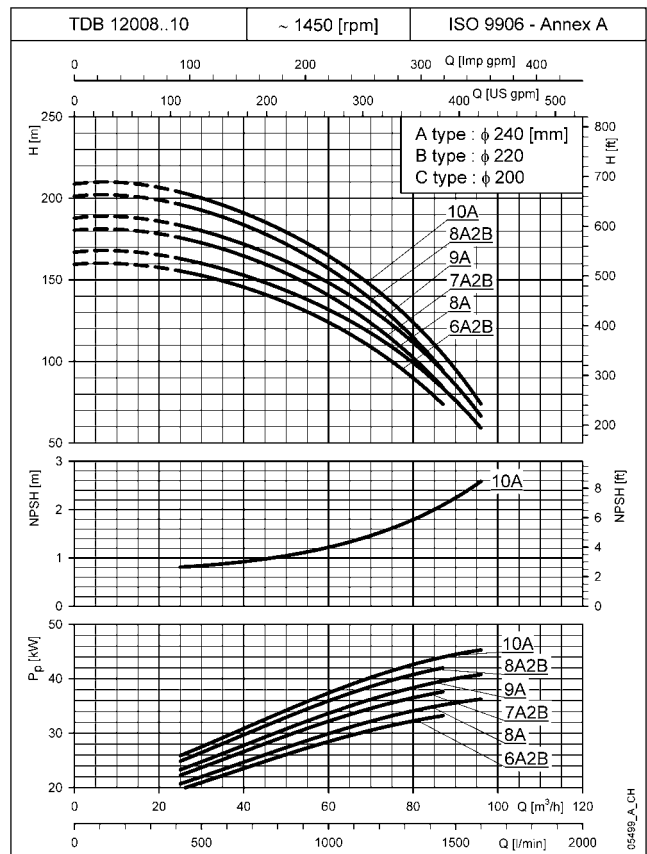
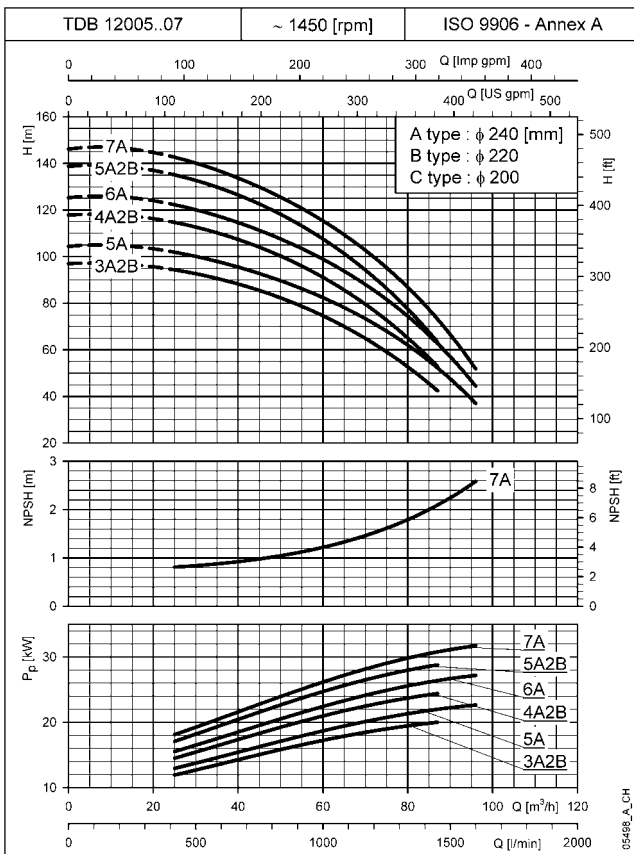
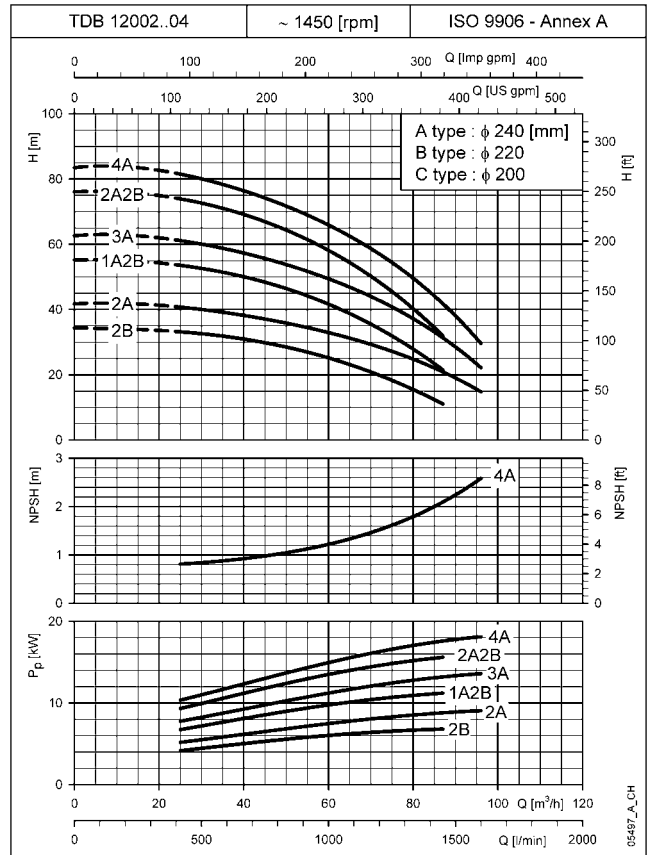
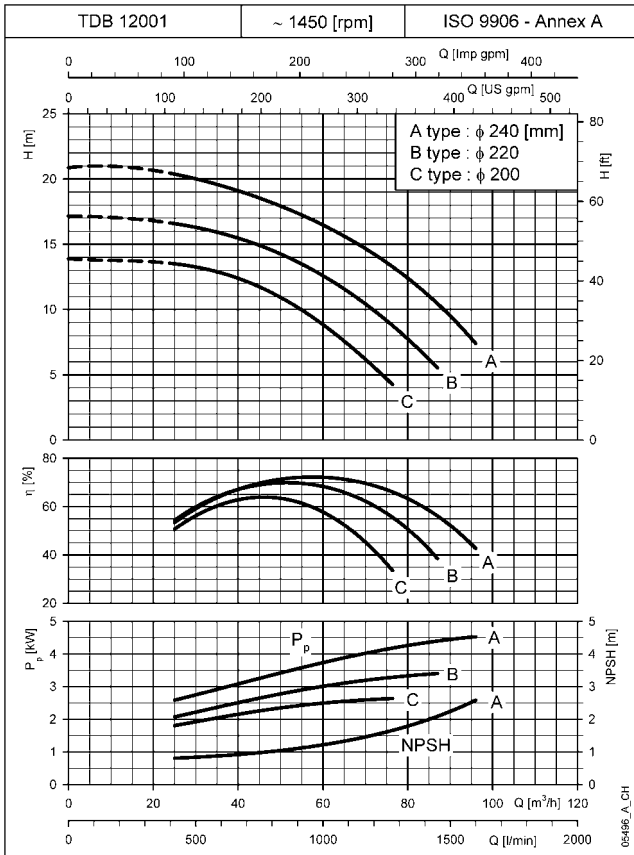

These performances are valid for liquids with density $\rho = 1,0 \text{ Kg/dm}^3$ and kinematic viscosity $\nu = 1 \text{ mm}^2/\text{sec}$.
The NPSH values are laboratory values; for practical use we suggest increasing these values by 0,5 m.

TDB170..4 SERIES OPERATING CHARACTERISTICS AT 50 Hz, 4 POLES

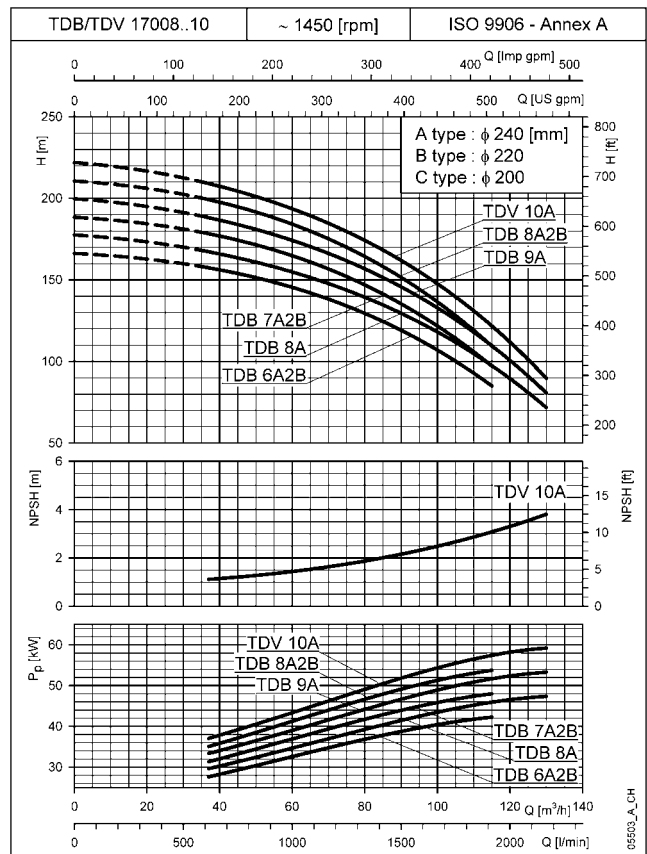
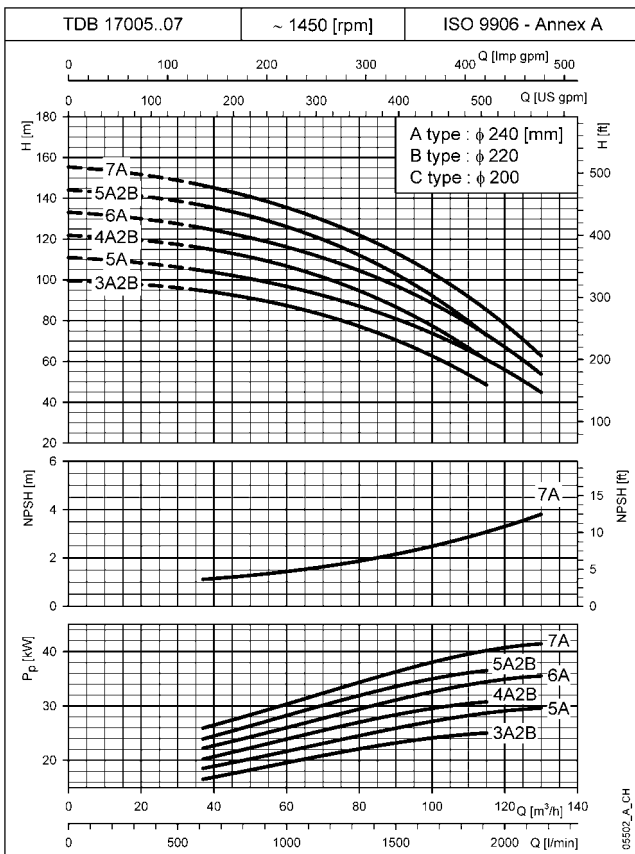
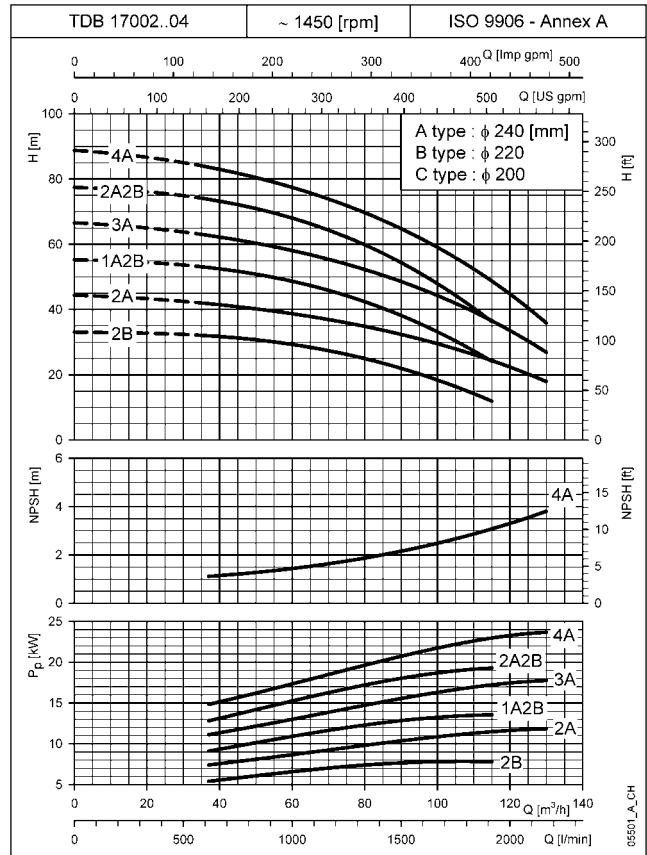
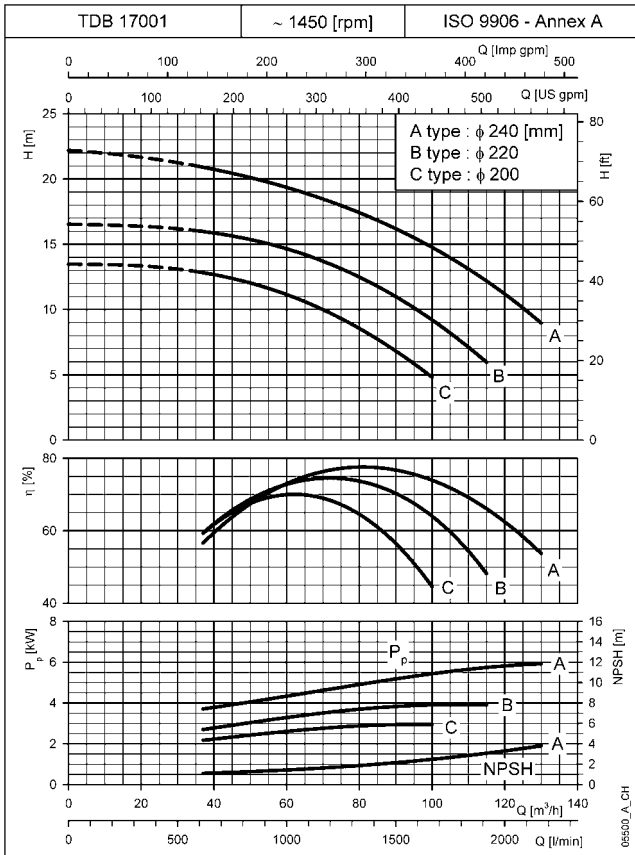

These performances are valid for liquids with density $\rho = 1,0 \text{ Kg/dm}^3$ and kinematic viscosity $\nu = 1 \text{ mm}^2/\text{sec}$.
The NPSH values are laboratory values; for practical use we suggest increasing these values by 0,5 m.

TDB220..4 SERIES OPERATING CHARACTERISTICS AT 50 Hz, 4 POLES

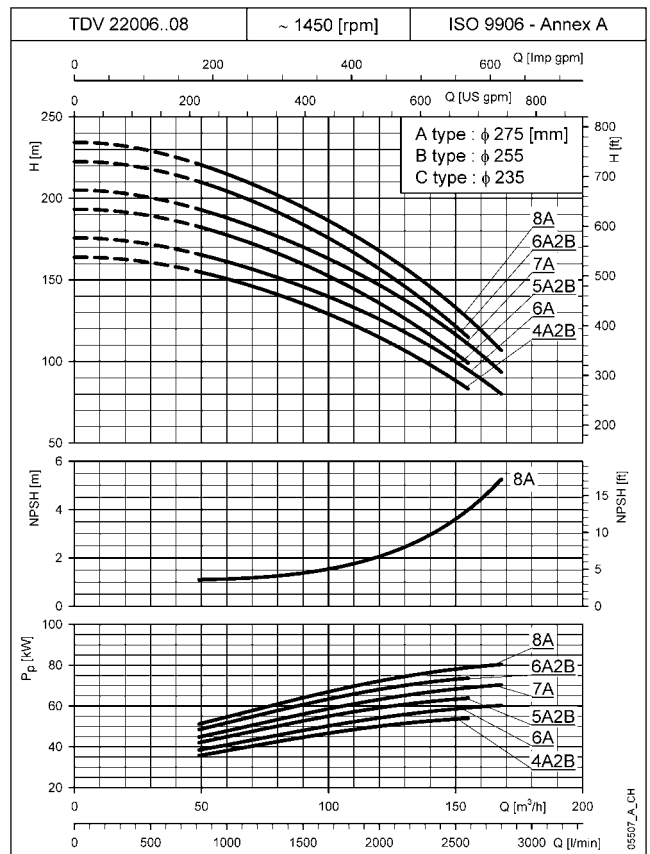
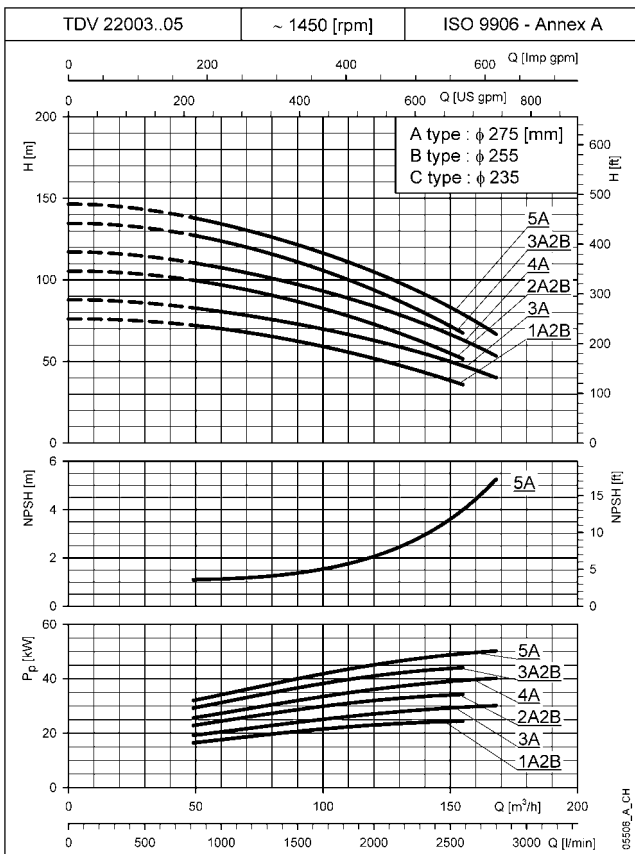
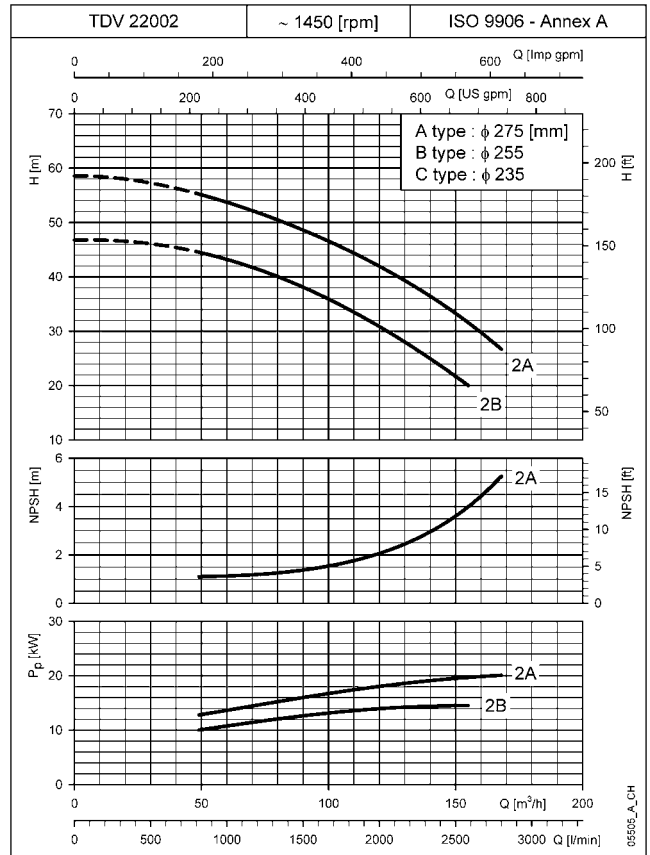
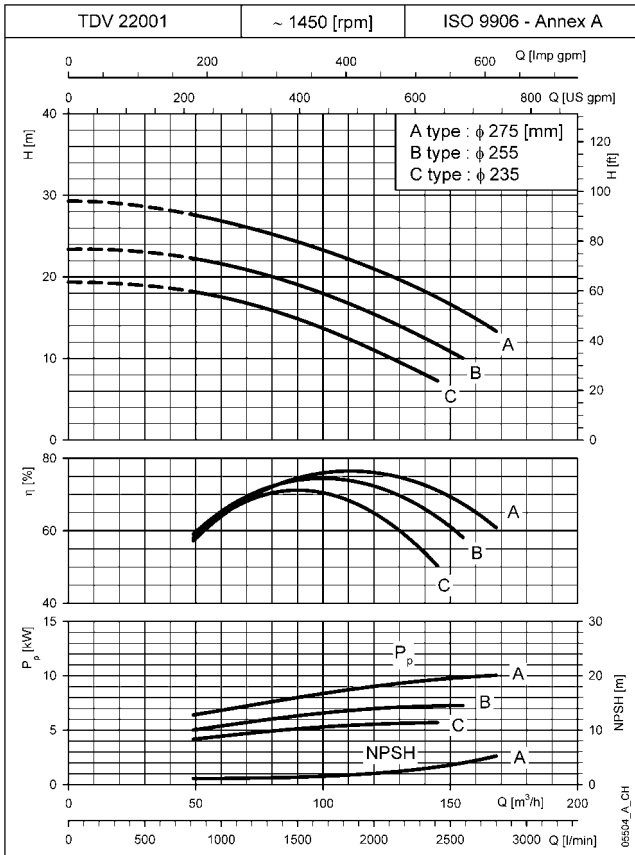

These performances are valid for liquids with density $\rho = 1,0 \text{ Kg/dm}^3$ and kinematic viscosity $\nu = 1 \text{ mm}^2/\text{sec}$.
The NPSH values are laboratory values; for practical use we suggest increasing these values by 0,5 m.

TDB280..4 SERIES OPERATING CHARACTERISTICS AT 50 Hz, 4 POLES

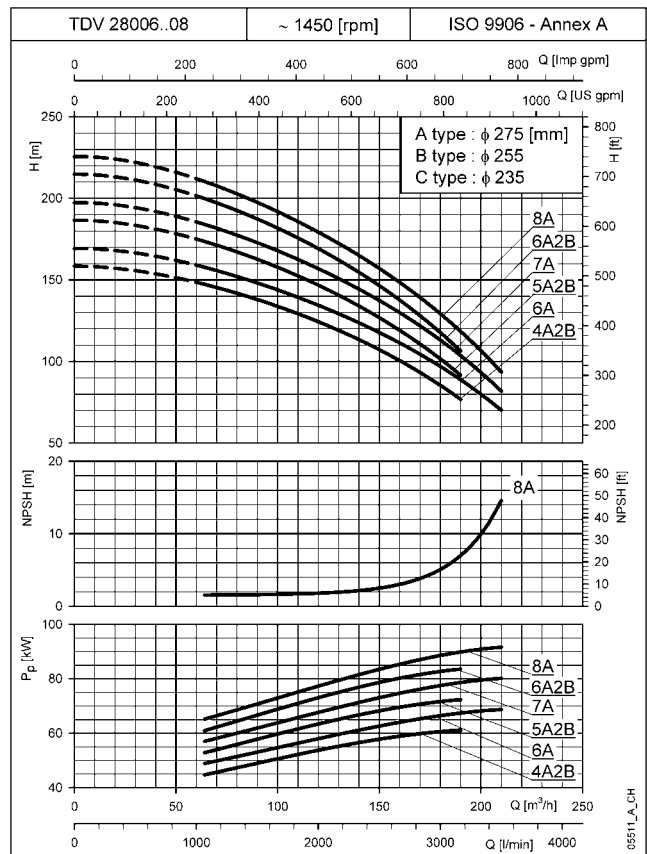
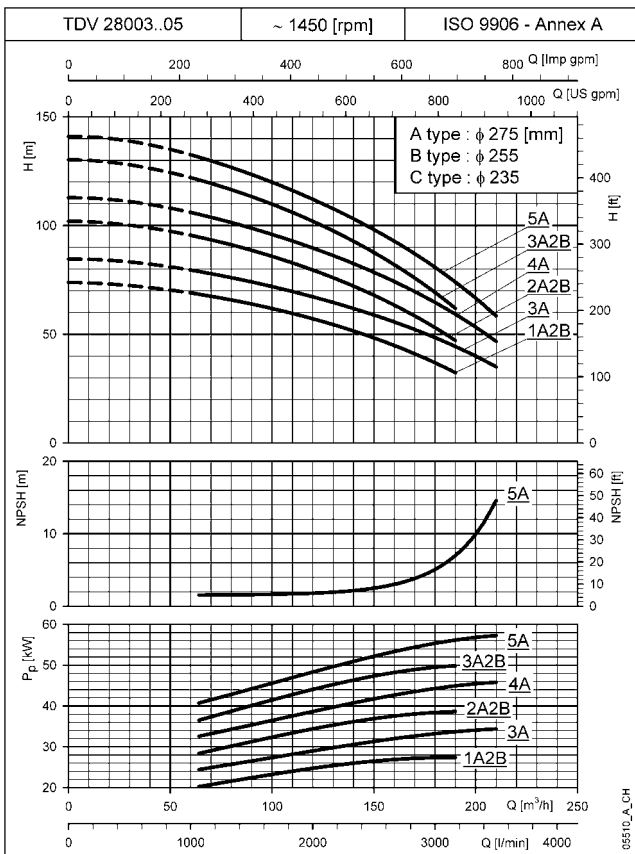
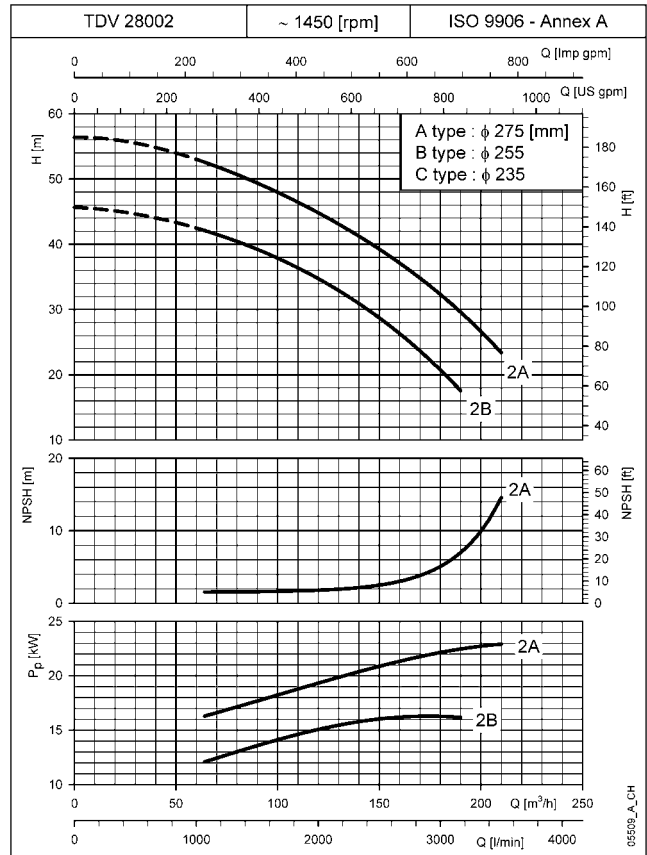
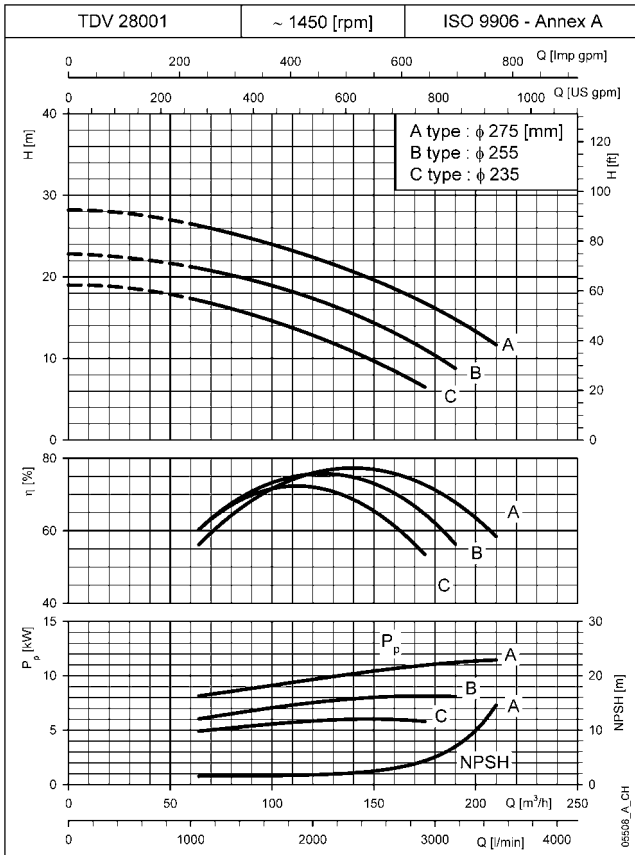

These performances are valid for liquids with density $\rho = 1,0 \text{ Kg/dm}^3$ and kinematic viscosity $\nu = 1 \text{ mm}^2/\text{sec}$.
 The NPSH values are laboratory values; for practical use we suggest increasing these values by 0,5 m.

DIMENSIONS AND WEIGHTS

TDB22 SERIES
DIMENSIONS AND WEIGHTS AT 50 Hz, 2 POLES

PUMP FLANGES

DN	PN	D	M	G	Z	F	C
DNM 40	10/16	156	110	84	4	19	22
	25/40	156	110	84	4	19	22
	63	178	125	84	4	23	28
DNA 65	10/16	191	145	118	4	19	24
	25(*)	191	145	118	8	19	24
	(*) ON REQUEST						

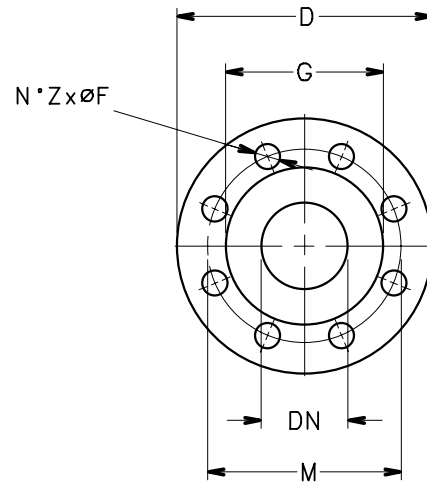

POSITION
OF 3-STAGE
FLANGES

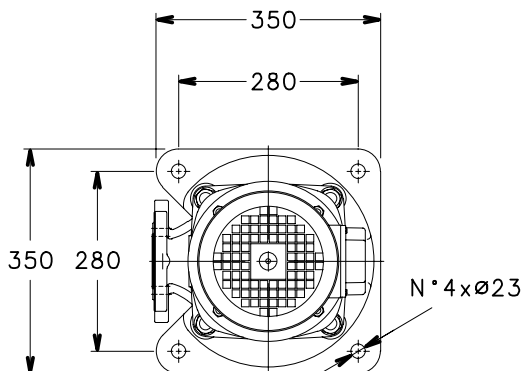
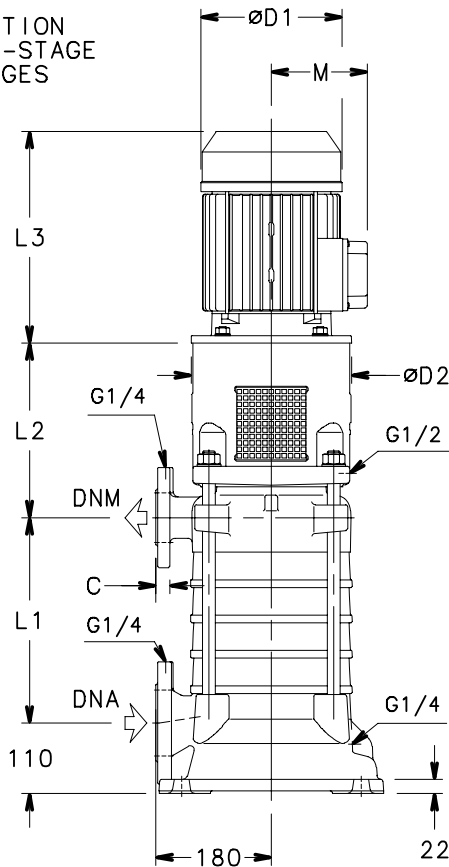

POSITION OF
FLANGES UP
TO 2 STAGES

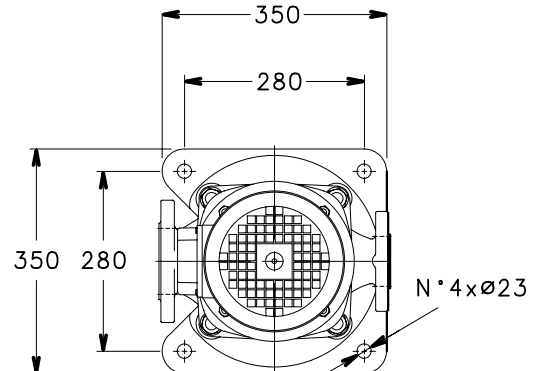
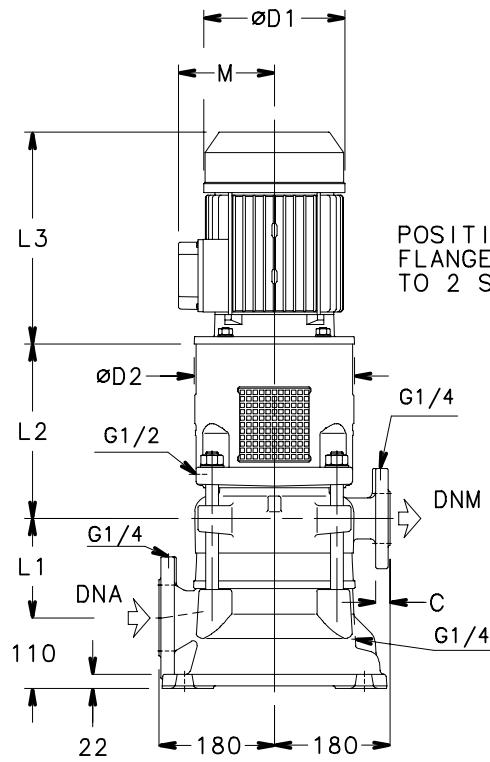

TDB22 SERIES DIMENSIONS AND WEIGHTS AT 50 Hz, 2 POLES

PUMP TYPE	MOTOR		DIMENSIONS (mm)						PN FLANGES		MECH SEAL TYPE	WEIGHT kg	
	kW	SIZE	L1	L2	L3	D1	D2	M	DNA	DNM		PUMP	ELECTRIC
TDB22 01/1C	2,2	90	100	262	298	174	200	134	10	40	SA	91	109
TDB22 01/1B	3	100R	100	272	298	174	250	134	10	40	SA	91	116
TDB22 01/1A	4	112R	100	272	319	197	250	154	10	40	SA	91	118
TDB22 02/2C	4	112R	155	272	319	197	250	154	10	40	SA	101	128
TDB22 02/1B1C	5,5	132R	155	292	375	214	300	168	10	40	SA	104	142
TDB22 02/2B	7,5	132	155	292	367	256	300	191	10	40	SA	104	160
TDB22 02/1A1B	7,5	132	155	292	367	256	300	191	10	40	SA	104	160
TDB22 02/2A	11	160R	155	322	428	256	350	191	10	40	SA	111	181
TDB22 03/2B1C	7,5	132	210	292	367	256	300	191	10	40	SA	114	170
TDB22 03/3B	11	160R	210	322	428	256	350	191	10	40	SA	122	192
TDB22 03/1A2B	11	160R	210	322	428	256	350	191	10	40	SA	122	192
TDB22 03/2A1B	15	160	210	322	494	313	350	240	10	40	SA	122	224
TDB22 03/3A	15	160	210	322	494	313	350	240	10	40	SA	122	224
TDB22 04/4B	15	160	265	322	494	313	350	240	10	40	SA	132	234
TDB22 04/1A3B	15	160	265	322	494	313	350	240	10	40	SA	132	234
TDB22 04/2A2B	15	160	265	322	494	313	350	240	10	40	SA	132	234
TDB22 04/3A1B	15	160	265	322	494	313	350	240	10	40	SA	132	234
TDB22 04/4A	18,5	160	265	322	494	313	350	240	10	40	SA	132	243
TDB22 05/1A4B	15	160	320	322	494	313	350	240	10	40	SB	143	245
TDB22 05/2A3B	18,5	160	320	322	494	313	350	240	10	40	SB	143	254
TDB22 05/3A2B	18,5	160	320	322	494	313	350	240	10	40	SB	143	254
TDB22 05/4A1B	22	180R	320	322	494	313	350	240	10	40	SB	143	264
TDB22 05/5A	22	180R	320	322	494	313	350	240	10	40	SB	143	264
TDB22 06/2A4B	22	180R	375	322	494	313	350	240	10	40	SB	153	274
TDB22 06/3A3B	22	180R	375	322	494	313	350	240	10	40	SB	153	274
TDB22 06/4A2B	22	180R	375	322	494	313	350	240	10	40	SB	153	274
TDB22 06/5A1B	30	200	375	322	657	402	400	317	10	40	SB	155	381
TDB22 06/6A	30	200	375	322	657	402	400	317	10	40	SB	155	381
TDB22 07/3A4B	30	200	430	322	657	402	400	317	10	40	SB	166	392
TDB22 07/4A3B	30	200	430	322	657	402	400	317	10	40	SB	166	392
TDB22 07/5A2B	30	200	430	322	657	402	400	317	10	40	SB	166	392
TDB22 07/6A1B	30	200	430	322	657	402	400	317	10	40	SB	166	392
TDB22 07/7A	30	200	430	322	657	402	400	317	10	40	SB	166	392
TDB22 08/4A4B	30	200	485	322	657	402	400	317	10	40	SB	176	402
TDB22 08/5A3B	30	200	485	322	657	402	400	317	10	40	SB	176	402
TDB22 08/6A2B	30	200	485	322	657	402	400	317	10	40	SB	176	402
TDB22 08/7A1B	37	200	485	322	657	402	400	317	10	40	SB	176	431
TDB22 08/8A	37	200	485	322	657	402	400	317	10	40	SB	176	431
TDB22 09/5A4B	30	200	540	322	657	402	400	317	10	40	SB	187	413
TDB22 09/6A3B	37	200	540	322	657	402	400	317	10	40	SB	187	442
TDB22 09/7A2B	37	200	540	322	657	402	400	317	10	40	SB	187	442
TDB22 09/8A1B	37	200	540	322	657	402	400	317	10	40	SB	187	442
TDB22 09/9A	37	200	540	322	657	402	400	317	10	40	SB	187	442
TDB22/10/6A4B	37	200	595	322	657	402	400	317	10	40/63	SB	197	452
TDB22 10/7A3B	37	200	595	322	657	402	400	317	10	40/63	SB	197	452
TDB22 10/8A2B	37	200	595	322	657	402	400	317	10	40/63	SB	197	452
TDB22 10/9A1B	45	225	595	322	746	455	450	384	10	40/63	SB	202	558
TDB22 10/10A	45	225	595	322	746	455	450	384	10	63	SB	202	558
TDB22 11/7A4B	45	225	650	322	746	455	450	384	10	63	SB	212	568
TDB22 11/8A3B	45	225	650	322	746	455	450	384	10	63	SB	212	568
TDB22 11/9A2B	45	225	650	322	746	455	450	384	10	63	SB	212	568
TDB22 11/10A1B	45	225	650	322	746	455	450	384	10	63	SB	212	568
TDB22 11/11A	45	225	650	322	746	455	450	384	10	63	SB	212	568
TDB22 12/8A4B	45	225	705	322	746	455	450	384	10	63	SB	223	579
TDB22 12/9A3B	45	225	705	322	746	455	450	384	10	63	SB	223	579
TDB22 12/10A2B	45	225	705	322	746	455	450	384	10	63	SB	223	579
TDB22 12/11A1B	55	250	705	352	825	486	550	402	10	63	SB	258	671
TDB22 12/12A	55	250	705	352	825	486	550	402	10	63	SB	258	671

TDB35 SERIES DIMENSIONS AND WEIGHTS AT 50 Hz, 2 POLES

PUMP FLANGES

DN	PN	D	M	G	Z	F	C
DNM 40	10/16	156	110	84	4	19	22
	25/40	156	110	84	4	19	22
	63	178	125	84	4	23	28
DNA 65	10/16	191	145	118	4	19	24
	25(*)	191	145	118	8	19	24
	(*) ON REQUEST						

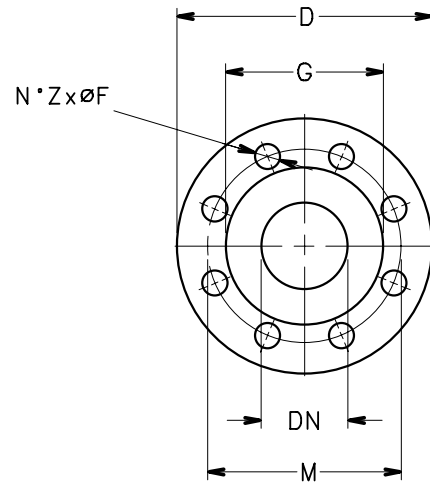

POSITION OF 3-STAGE FLANGES

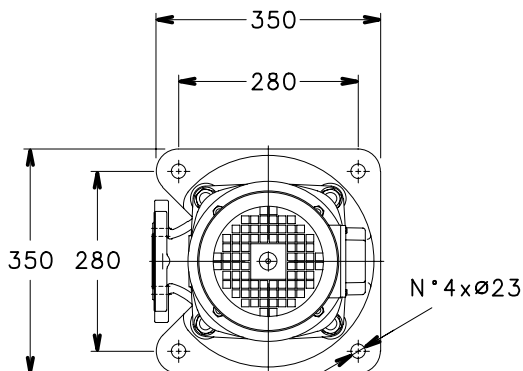
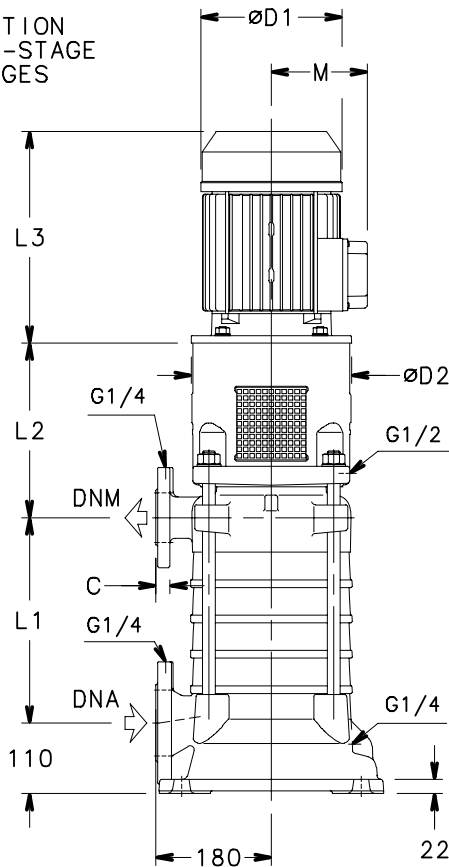

POSITION OF FLANGES UP TO 2 STAGES

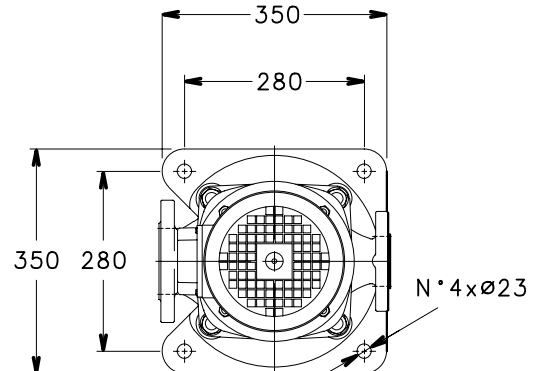
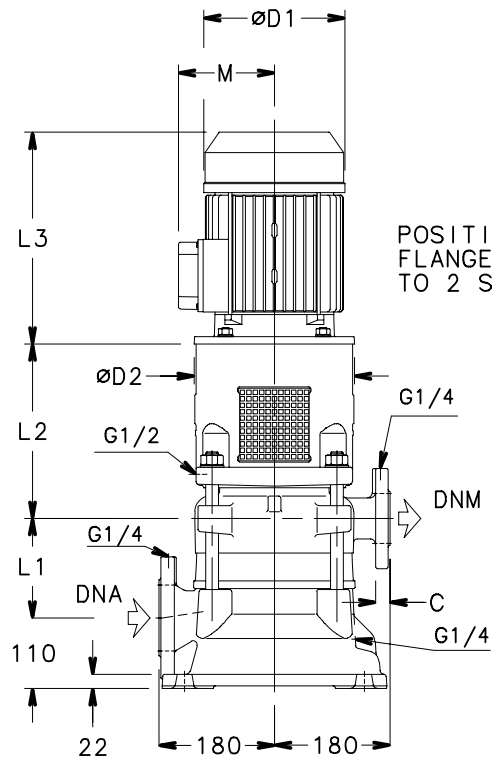

TDB35 SERIES

DIMENSIONS AND WEIGHTS AT 50 Hz, 2 POLES

PUMP TYPE	MOTOR		DIMENSIONS (mm)						PN FLANGES		MECH SEAL TYPE	WEIGHT kg	
	kW	SIZE	L1	L2	L3	D1	D2	M	DNA	DNM		PUMP	ELECTRIC
TDB35 01/1C	3	100R	100	272	298	174	250	134	10	40	SA	91	116
TDB35 01/1B	4	112R	100	272	319	197	250	154	10	40	SA	91	118
TDB35 01/1A	5,5	132R	100	292	375	214	300	168	10	40	SA	93	131
TDB35 02/2B	7,5	132	155	292	367	256	300	191	10	40	SA	104	160
TDB35 02/1A1B	11	160R	155	322	428	256	350	191	10	40	SA	111	181
TDB35 02/2A	11	160R	155	322	428	256	350	191	10	40	SA	111	181
TDB35 03/3B	11	160R	210	322	428	256	350	191	10	40	SA	122	192
TDB35 03/1A2B	15	160	210	322	494	313	350	240	10	40	SA	122	224
TDB35 03/2A1B	15	160	210	322	494	313	350	240	10	40	SA	122	224
TDB35 03/3A	18,5	160	210	322	494	313	350	240	10	40	SA	122	233
TDB35 04/1A3B	18,5	160	265	322	494	313	350	240	10	40	SA	132	243
TDB35 04/2A2B	18,5	160	265	322	494	313	350	240	10	40	SA	132	243
TDB35 04/3A1B	22	180R	265	322	494	313	350	240	10	40	SA	132	253
TDB35 04/4A	22	180R	265	322	494	313	350	240	10	40	SA	132	253
TDB35 05/2A3B	22	180R	320	322	494	313	350	240	10	40	SB	143	264
TDB35 05/3A2B	30	200	320	322	657	402	400	317	10	40	SB	145	371
TDB35 05/4A1B	30	200	320	322	657	402	400	317	10	40	SB	145	371
TDB35 05/5A	30	200	320	322	657	402	400	317	10	40	SB	145	371
TDB35 06/3A3B	30	200	375	322	657	402	400	317	10	40	SB	155	381
TDB35 06/4A2B	30	200	375	322	657	402	400	317	10	40	SB	155	381
TDB35 06/5A1B	30	200	375	322	657	402	400	317	10	40	SB	155	381
TDB35 06/6A	37	200	375	322	657	402	400	317	10	40	SB	155	410
TDB35 07/4A3B	37	200	430	322	657	402	400	317	10	40	SB	166	421
TDB35 07/5A2B	37	200	430	322	657	402	400	317	10	40	SB	166	421
TDB35 07/6A1B	37	200	430	322	657	402	400	317	10	40	SB	166	421
TDB35 07/7A	37	200	430	322	657	402	400	317	10	40	SB	166	421
TDB35 08/5A3B	37	200	485	322	657	402	400	317	10	40	SB	176	431
TDB35 08/6A2B	37	200	485	322	657	402	400	317	10	40	SB	176	431
TDB35 08/7A1B	45	225	485	322	746	455	450	384	10	40	SB	181	537
TDB35 08/8A	45	225	485	322	746	455	450	384	10	40	SB	181	537
TDB35 09/6A3B	45	225	540	322	746	455	450	384	10	40	SB	191	547
TDB35 09/7A2B	45	225	540	322	746	455	450	384	10	40	SB	191	547
TDB35 09/8A1B	45	225	540	322	746	455	450	384	10	40	SB	191	547
TDB35 09/9A	55	250	540	352	825	486	550	402	10	40	SB	226	639
TDB35 10/7A3B	55	250	595	352	825	486	550	402	10	40/63	SB	237	650
TDB35 10/8A2B	55	250	595	352	825	486	550	402	10	40/63	SB	237	650
TDB35 10/9A1B	55	250	595	352	825	486	550	402	10	40/63	SB	237	650
TDB35 10/10A	55	250	595	352	825	486	550	402	10	40/63	SB	237	650
TDB35 11/8A3B	55	250	650	352	825	486	550	402	10	63	SB	247	660
TDB35 11/9A2B	55	250	650	352	825	486	550	402	10	63	SB	247	660
TDB35 11/10A1B	55	250	650	352	825	486	550	402	10	63	SB	247	660
TDB35 11/11A	75	280	650	352	931	599	550	472	10	63	SB	247	877
TDB35 12/9A3B	55	250	705	352	825	486	550	402	10	63	SB	258	671
TDB35 12/10A2B	75	280	705	352	931	599	550	472	10	63	SB	258	888
TDB35 12/11A1B	75	280	705	352	931	599	550	472	10	63	SB	258	888
TDB35 12/12A	75	280	705	352	931	599	550	472	10	63	SB	258	888

Weights refer to Version F (Cast Iron)

tdb35-2p50-en_c_td

TDB58 SERIES
DIMENSIONS AND WEIGHTS AT 50 Hz, 2 POLES

PUMP FLANGES

DN	PN	D	M	G	Z	F	C
DNM 65	10/16	191	145	118	4	19	24
	25/40	191	145	118	8	19	24
	63	205	160	118	8	23	28
DNA 100	10/16	235	180	156	8	19	27
	25(*)	235	190	156	8	23	27
	(*) ON REQUEST						

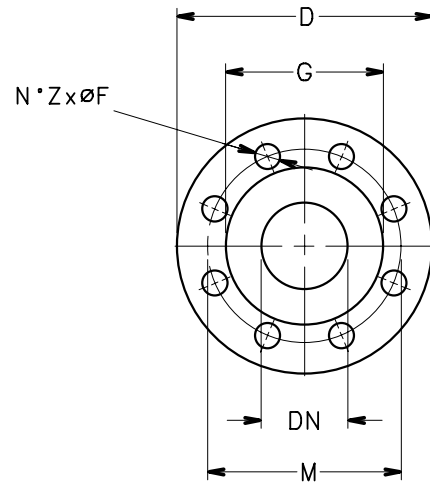

POSITION OF 3-STAGE FLANGES

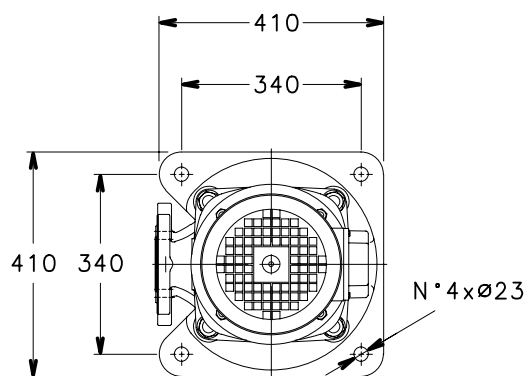
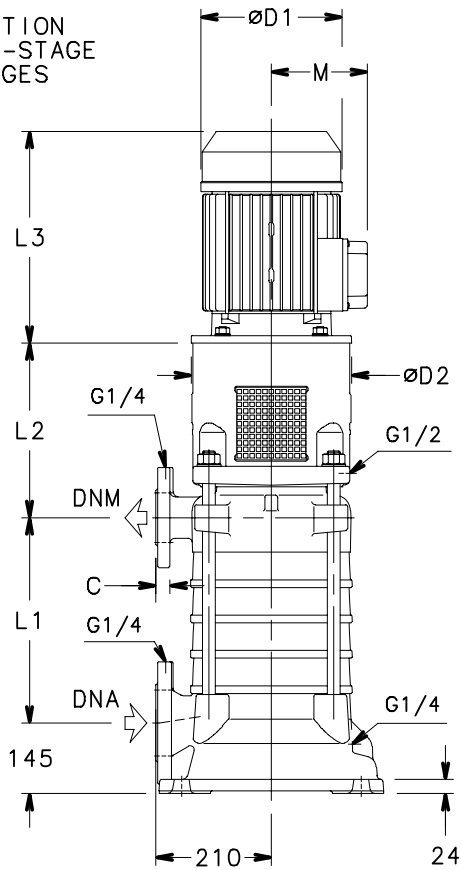

POSITION OF FLANGES UP TO 2 STAGES

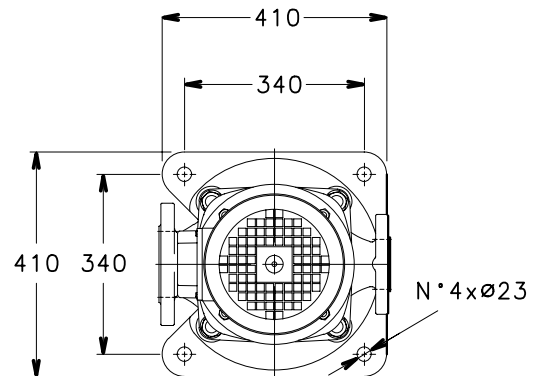
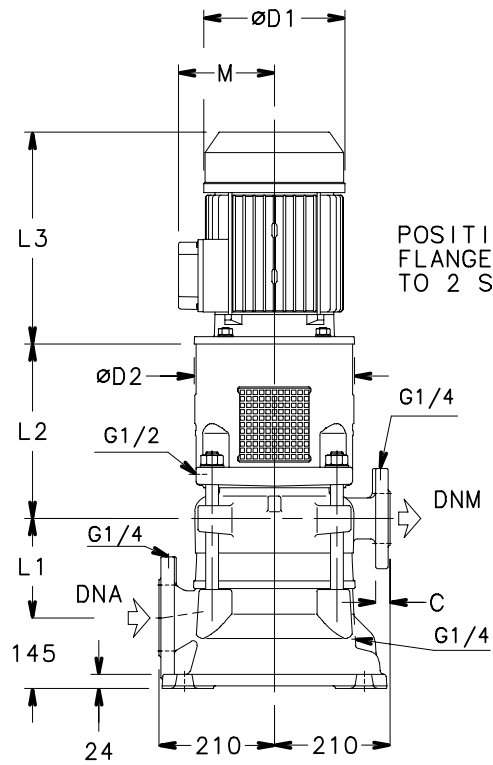

05401-EN_A_DD

TDB58 SERIES

DIMENSIONS AND WEIGHTS AT 50 Hz, 2 POLES

PUMP TYPE	MOTOR		DIMENSIONS (mm)						PN FLANGES		MECH. SEAL TYPE	WEIGHT kg	
	kW	SIZE	L1	L2	L3	D1	D2	M	DNA	DNM		PUMP	ELECTRIC
TDB58 01/1C	7,5	132	125	311	367	256	300	191	10	16	SA	133	189
TDB58 01/1B	7,5	132	125	311	367	256	300	191	10	16	SA	133	189
TDB58 01/1A	11	160R	125	341	428	256	350	191	10	16	SA	143	213
TDB58 02/2C	15	160	195	341	494	313	350	240	10	16	SA	160	262
TDB58 02/1B1C	15	160	195	341	494	313	350	240	10	16	SA	160	262
TDB58 02/2B	18,5	160	195	341	494	313	350	240	10	16	SA	160	271
TDB58 02/1A1B	18,5	160	195	341	494	313	350	240	10	16	SA	160	271
TDB58 02/2A	22	180R	195	341	494	313	350	240	10	16	SA	160	281
TDB58 03/2B1C	22	180R	265	341	494	313	350	240	10	16	SA	176	297
TDB58 03/3B	30	200	265	341	657	402	400	317	10	16/40	SA/SB	179	405
TDB58 03/1A2B	30	200	265	341	657	402	400	317	10	16/40	SA/SB	179	405
TDB58 03/2A1B	30	200	265	341	657	402	400	317	10	16/40	SA/SB	179	405
TDB58 03/3A	37	200	265	341	657	402	400	317	10	16/40	SA/SB	179	434
TDB58 04/4B	30	200	335	341	657	402	400	317	10	40	SB	196	422
TDB58 04/1A3B	37	200	335	341	657	402	400	317	10	40	SB	196	451
TDB58 04/2A2B	37	200	335	341	657	402	400	317	10	40	SB	196	451
TDB58 04/3A1B	45	225	335	341	746	455	450	384	10	40	SB	201	557
TDB58 04/4A	45	225	335	341	746	455	450	384	10	40	SB	201	557
TDB58 05/1A4B	45	225	405	341	746	455	450	384	10	40	SB	217	573
TDB58 05/2A3B	45	225	405	341	746	455	450	384	10	40	SB	217	573
TDB58 05/3A2B	55	250	405	371	825	486	550	402	10	40	SB	227	640
TDB58 05/4A1B	55	250	405	371	825	486	550	402	10	40	SB	227	640
TDB58 05/5A	55	250	405	371	825	486	550	402	10	40	SB	227	640
TDB58 06/2A4B	55	250	475	371	825	486	550	402	10	40	SB	244	657
TDB58 06/3A3B	55	250	475	371	825	486	550	402	10	40	SB	244	657
TDB58 06/4A2B	75	280	475	371	931	599	550	472	10	40	SB	244	874
TDB58 06/5A1B	75	280	475	371	931	599	550	472	10	40	SB	244	874
TDB58 06/6A	75	280	475	371	931	599	550	472	10	40	SB	244	874
TDB58 07/3A4B	75	280	545	371	931	599	550	472	10	40	SB	260	890
TDB58 07/4A3B	75	280	545	371	931	599	550	472	10	40/63	SB	260	890
TDB58 07/5A2B	75	280	545	371	931	599	550	472	10	40/63	SB	260	890
TDB58 07/6A1B	75	280	545	371	931	599	550	472	10	40/63	SB	260	890
TDB58 07/7A	75	280	545	371	931	599	550	472	10	40/63	SB	260	890
TDB58 08/4A4B	75	280	615	371	931	599	550	472	10	40/63	SB	277	907
TDB58 08/5A3B	90	280	615	371	931	599	550	472	10	40/63	SB	277	930
TDB58 08/6A2B	90	280	615	371	931	599	550	472	10	63	SB	277	930
TDB58 08/7A1B	90	280	615	371	931	599	550	472	10	63	SB	277	930
TDB58 08/8A	90	280	615	371	931	599	550	472	10	63	SB	277	930
TDB58 09/5A4B	90	280	685	371	931	599	550	472	10	63	SB	293	946
TDB58 09/6A3B	90	280	685	371	931	599	550	472	10	63	SB	293	946
TDB58 09/7A2B	90	280	685	371	931	599	550	472	10	63	SB	293	946

Weights refer to Version F (Cast Iron)

tdb58-2p50-en_b_td

TDB78 SERIES
DIMENSIONS AND WEIGHTS AT 50 Hz, 2 POLES

PUMP FLANGES

DN	PN	D	M	G	Z	F	C
DNM 65	10/16	191	145	118	4	19	24
	25/40	191	145	118	8	19	24
	63	205	160	118	8	23	28
DNA 100	10/16	235	180	156	8	19	27
	25(*)	235	190	156	8	23	27
	(*) ON REQUEST						

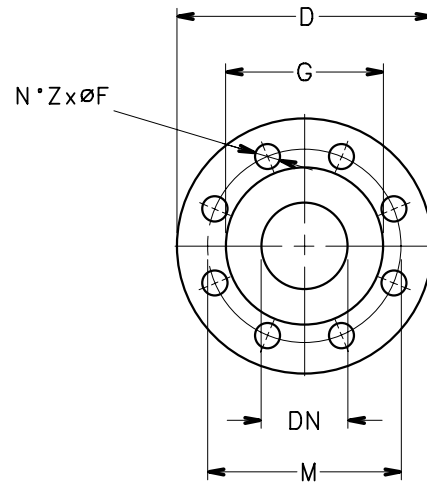

POSITION OF 3-STAGE FLANGES

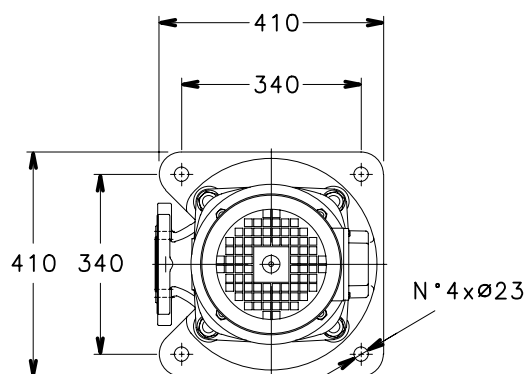
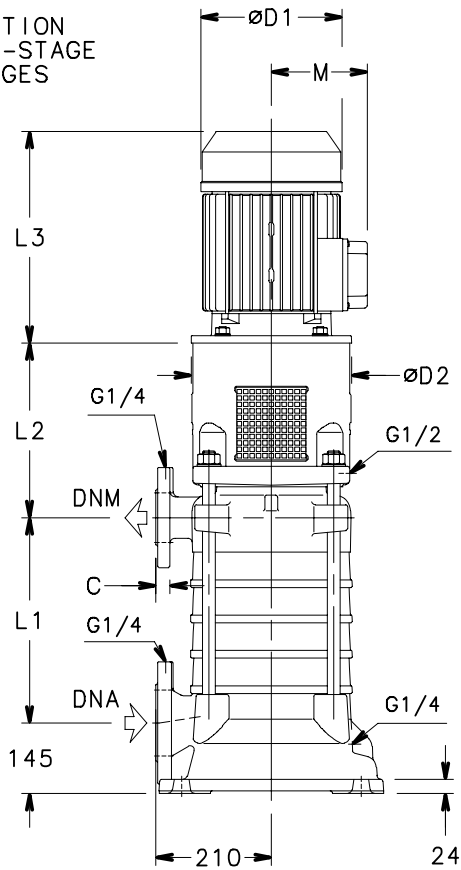

POSITION OF FLANGES UP TO 2 STAGES

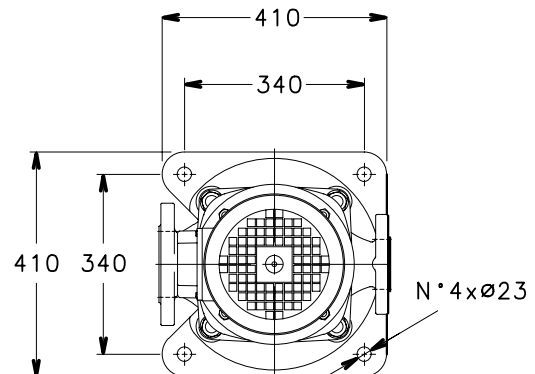
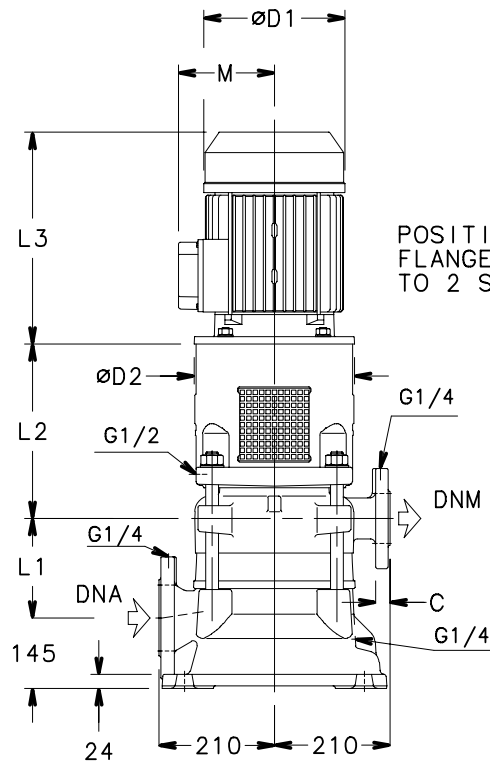

TDB78 SERIES

DIMENSIONS AND WEIGHTS AT 50 Hz, 2 POLES

PUMP TYPE	MOTOR		DIMENSIONS (mm)						PN FLANGES		MECH. SEAL TYPE	WEIGHT kg	
	kW	SIZE	L1	L2	L3	D1	D2	M	DNA	DNM		PUMP	ELECTRIC
TDB78 01/1C	7,5	132	125	311	367	256	300	191	10	16	SA	133	189
TDB78 01/1B	11	160R	125	341	428	256	350	191	10	16	SA	143	213
TDB78 01/1A	15	160	125	341	494	313	350	240	10	16	SA	143	245
TDB78 02/1B1C	18,5	160	195	341	494	313	350	240	10	16	SA	160	271
TDB78 02/2B	22	180R	195	341	494	313	350	240	10	16	SA	160	281
TDB78 02/1A1B	30	200	195	341	657	402	400	317	10	16	SA	163	389
TDB78 02/2A	37	200	195	341	657	402	400	317	10	16	SA	163	418
TDB78 03/3B	37	200	265	341	657	402	400	317	10	16/40	SA/SB	179	434
TDB78 03/1A2B	37	200	265	341	657	402	400	317	10	16/40	SA/SB	179	434
TDB78 03/2A1B	45	225	265	341	746	455	450	384	10	16/40	SA/SB	184	540
TDB78 03/3A	55	250	265	371	825	486	550	402	10	40	SB	194	607
TDB78 04/1A3B	55	250	335	371	825	486	550	402	10	40	SB	211	624
TDB78 04/2A2B	55	250	335	371	825	486	550	402	10	40	SB	211	624
TDB78 04/3A1B	75	280	335	371	931	599	550	472	10	40	SB	211	841
TDB78 04/4A	75	280	335	371	931	599	550	472	10	40	SB	211	841
TDB78 05/2A3B	75	280	405	371	931	599	550	472	10	40	SB	227	857
TDB78 05/3A2B	75	280	405	371	931	599	550	472	10	40	SB	227	857
TDB78 05/4A1B	75	280	405	371	931	599	550	472	10	40	SB	227	857
TDB78 05/5A	90	280	405	371	931	599	550	472	10	40	SB	227	880
TDB78 06/3A3B	90	280	475	371	931	599	550	472	10	40	SB	244	897
TDB78 06/4A2B	90	280	475	371	931	599	550	472	10	40	SB	244	897
TDB78 06/5A1B	90	280	475	371	931	599	550	472	10	40	SB	244	897

Weights refer to Version F (Cast Iron)

tdb78-2p50-en_b_td

TDB-TDV120 SERIES DIMENSIONS AND WEIGHTS AT 50 Hz, 2 POLES

PUMP FLANGES

DN	PN	D	M	G	Z	F	C
DNM 100	10/16	235	180	156	8	19	27
	25/40	235	190	156	8	23	27
	63	273	200	156	8	28	32
DNA 125	10/16	279	210	184	8	19	29
	25(*)	279	220	184	8	28	29
(*) ON REQUEST							

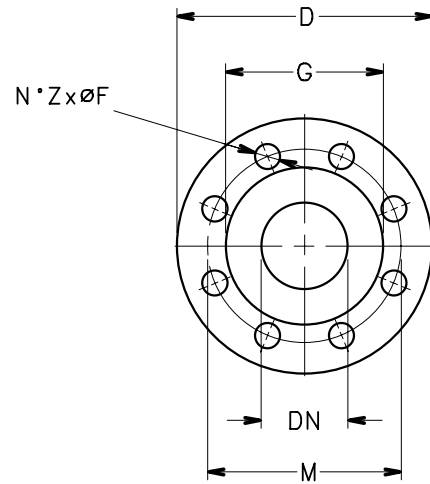

POSITION OF 3-STAGE FLANGES

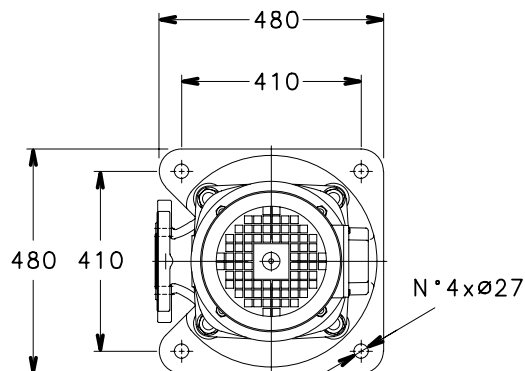
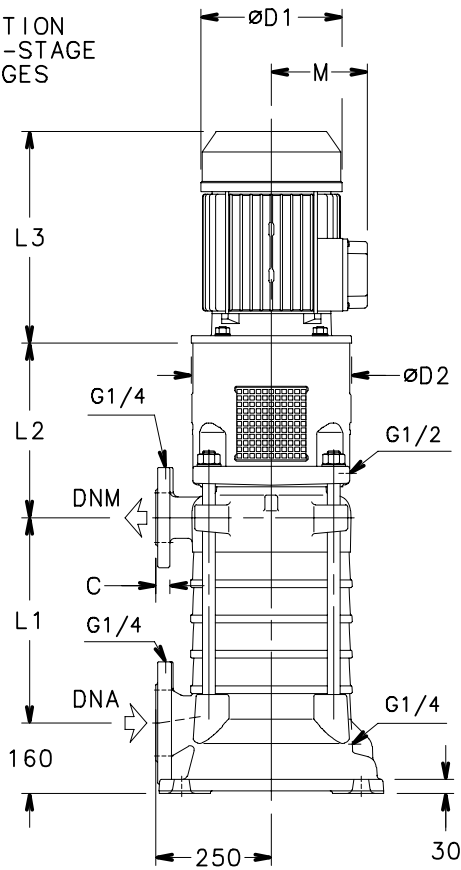

POSITION OF FLANGES UP TO 2 STAGES

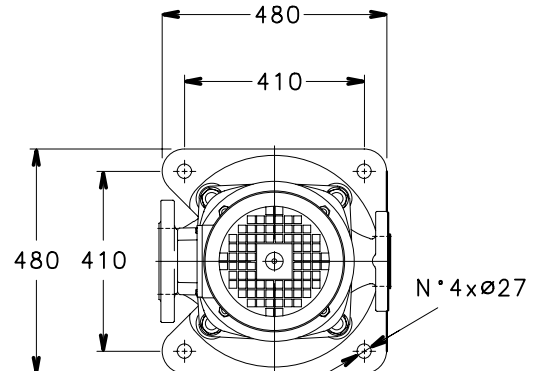
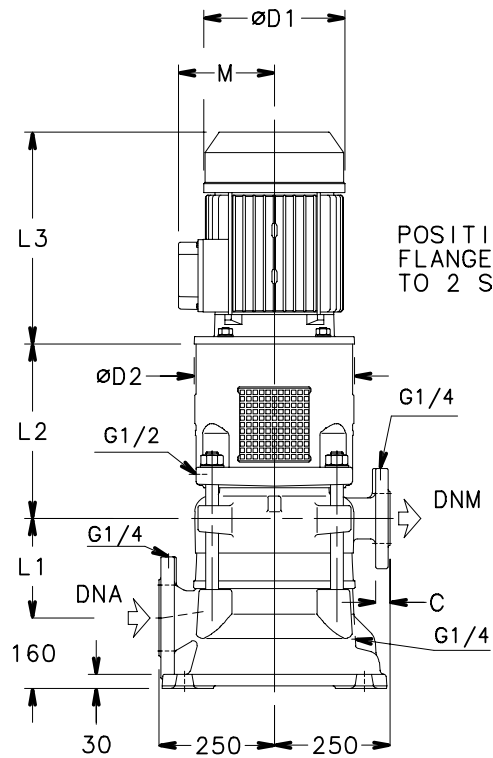

TDB-TDV120 SERIES

DIMENSIONS AND WEIGHTS AT 50 Hz, 2 POLES

PUMP TYPE	MOTOR		DIMENSIONS (mm)						PN FLANGES		MECH. SEAL TYPE	WEIGHT kg	
	kW	SIZE	L1	L2	L3	D1	D2	M	DNA	DNM		PUMP	ELECTRIC
TDB120 01/1C	22	180R	175	371	494	313	350	240	10	16	SA	270	391
TDB120 01/1B	30	200	175	371	657	402	400	317	10	16	SA	271	497
TDB120 01/1A	37	200	175	371	657	402	400	317	10	16	SA	271	526
TDB120 02/2C	45	225	260	371	746	455	450	384	10	16	SA	304	660
TDB120 02/1B1C	55	250	260	401	825	486	550	402	10	16/40	SA/SB	311	724
TDB120 02/2B	55	250	260	401	825	486	550	402	10	16/40	SA/SB	311	724
TDB120 02/1A1B	75	280	260	401	931	599	550	472	10	16/40	SA/SB	311	941
TDB120 02/2A	75	280	260	401	931	599	550	472	10	40	SA/SB	311	941
TDB120 03/1B2C	75	280	345	401	931	599	550	472	10	40	SB	343	973
TDB120 03/2B1C	75	280	345	401	931	599	550	472	10	40	SB	343	973
TDB120 03/3B	90	280	345	401	931	599	550	472	10	40	SB	343	996
TDB120 03/1A2B	90	280	345	401	931	599	550	472	10	40	SB	343	996
TDV120 03/2A1B	110	315	345	514	1104	657	660	530	10	40	SB	394	1268
TDV120 03/3A	110	315	345	514	1104	657	660	530	10	40	SB	394	1268
TDV120 04/4B	110	315	430	514	1104	657	660	530	10	40	SB	426	1300
TDV120 04/1A3B	132	315	430	514	1104	657	660	530	10	40	SB	426	1357
TDV120 04/2A2B	132	315	430	514	1104	657	660	530	10	40	SB	426	1357
TDV120 04/3A1B	160	315	430	514	1104	657	660	530	10	40	SB	431	1426
TDV120 04/4A	160	315	430	514	1104	657	660	530	10	40	SB	431	1426
TDV120 05/1A4B	160	315	515	514	1104	657	660	530	10	40/63	SB	463	1458
TDV120 05/2A3B	160	315	515	514	1104	657	660	530	10	40/63	SB	463	1458
TDV120 05/3A2B	160	315	515	514	1104	657	660	530	10	40/63	SB	463	1458
TDV120 05/4A1B	200	315	515	514	1104	657	660	530	10	63	SB	463	1638
TDV120 05/5A	200	315	515	514	1104	657	660	530	10	63	SB	463	1638
TDV120 06/2A4B	200	315	600	514	1104	657	660	530	10	63	SB	495	1670
TDV120 06/3A3B	200	315	600	514	1104	657	660	530	10	63	SB	495	1670
TDV120 06/4A2B	200	315	600	514	1104	657	660	530	10	63	SB	495	1670
TDV120 06/5A1B	200	315	600	514	1104	657	660	530	10	63	SB	495	1670
TDV120 06/6A	200	315	600	514	1104	657	660	530	10	63	SB	495	1670

Weights refer to Version F (Cast Iron)

tdb-tdv120-2p50-en_d_td

TDB-TDV170 SERIES DIMENSIONS AND WEIGHTS AT 50 Hz, 2 POLES

PUMP FLANGES

DN	PN	D	M	G	Z	F	C
DNM 100	10/16	235	180	156	8	19	27
	25/40	235	190	156	8	23	27
	63	273	200	156	8	28	32
DNA 125	10/16	279	210	184	8	19	29
	25(*)	279	220	184	8	28	29
(*) ON REQUEST							

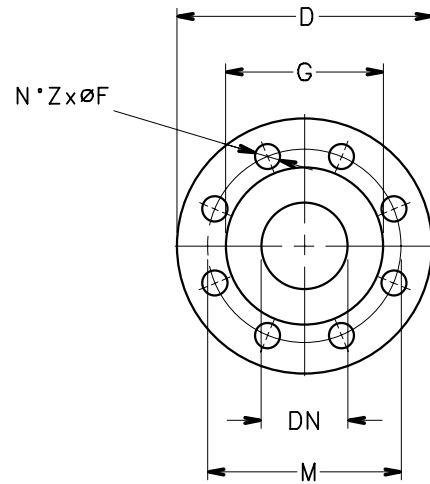

POSITION OF 3-STAGE FLANGES

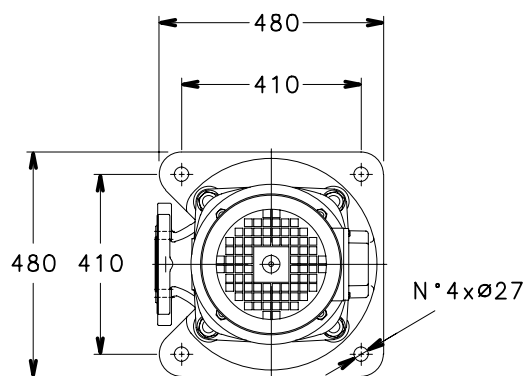
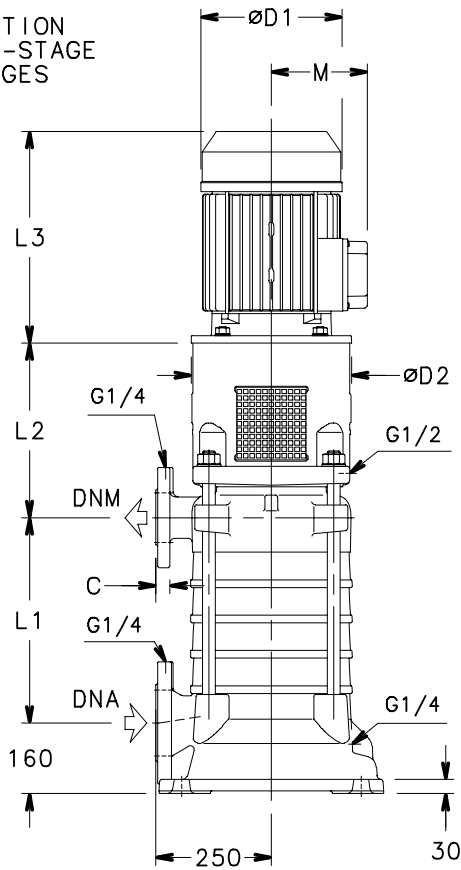

POSITION OF FLANGES UP TO 2 STAGES

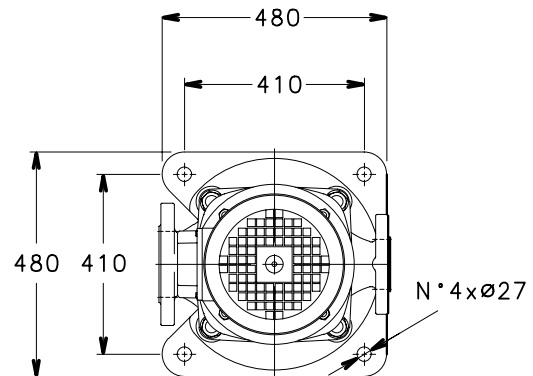
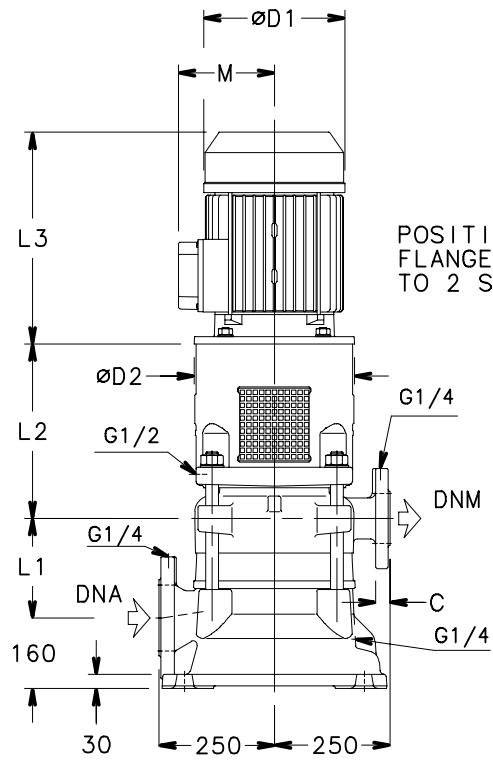

TDB-TDV170 SERIES

DIMENSIONS AND WEIGHTS AT 50 Hz, 2 POLES

PUMP TYPE	MOTOR		DIMENSIONS (mm)						PN FLANGES		MECH. SEAL TYPE	WEIGHT kg	
	kW	SIZE	L1	L2	L3	D1	D2	M	DNA	DNM		PUMP	ELECTRIC
TDB170 01/1C	30	200	175	371	657	402	400	317	10	16	SA	271	497
TDB170 01/1B	37	200	175	371	657	402	400	317	10	16	SA	271	526
TDB170 01/1A	45	225	175	371	746	455	450	384	10	16	SA	272	628
TDB170 01/1A	55	250	175	401	825	486	550	402	10	16	SA	279	692
TDB170 02/2C	55	250	260	401	825	486	550	402	10	16/40	SA/SB	311	724
TDB170 02/1B1C	55	250	260	401	825	486	550	402	10	16/40	SA/SB	311	724
TDB170 02/2B	75	280	260	401	931	599	550	472	10	16/40	SA/SB	311	941
TDB170 02/1A1B	90	280	260	401	931	599	550	472	10	16/40	SA/SB	311	964
TDV170 02/2A	110	315	260	514	1104	657	660	530	10	40	SA/SB	362	1236
TDV170 03/2B1C	110	315	345	514	1104	657	660	530	10	40	SB	394	1268
TDV170 03/3B	110	315	345	514	1104	657	660	530	10	40	SB	394	1268
TDV170 03/1A2B	110	315	345	514	1104	657	660	530	10	40	SB	394	1268
TDV170 03/2A1B	132	315	345	514	1104	657	660	530	10	40	SB	394	1325
TDV170 03/3A	160	315	345	514	1104	657	660	530	10	40	SB	399	1394
TDV170 04/1A3B	160	315	430	514	1104	657	660	530	10	40	SB	431	1426
TDV170 04/2A2B	160	315	430	514	1104	657	660	530	10	40	SB	431	1426
TDV170 04/3A1B	200	315	430	514	1104	657	660	530	10	40	SB	431	1606
TDV170 04/4A	200	315	430	514	1104	657	660	530	10	40/63	SB	431	1606
TDV170 05/2A3B	200	315	515	514	1104	657	660	530	10	40/63	SB	463	1638
TDV170 05/3A2B	200	315	515	514	1104	657	660	530	10	40/63	SB	463	1638

Weights refer to Version F (Cast Iron)

tdb-tdv170-2p50-en_c_td

TDV220 SERIES DIMENSIONS AND WEIGHTS AT 50 Hz, 2 POLES

PUMP FLANGES

DN	PN	D	M	G	Z	F	C
DNM 125	10/16	279	210	184	8	19	29
	25/40	279	220	184	8	28	29
	63	330	240	184	8	31	35
DNA 150	10/16	300	240	211	8	23	32
	25(*)	300	250	211	8	28	32
(*) ON REQUEST							

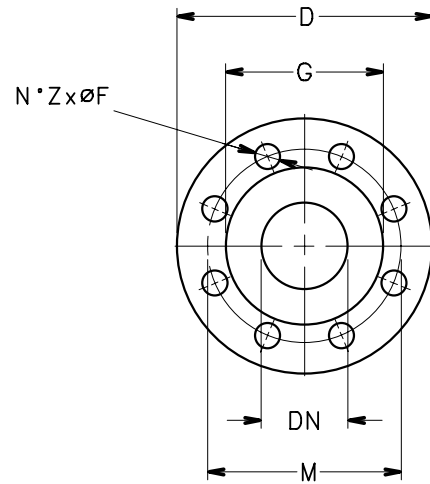

POSITION OF 3-STAGE FLANGES

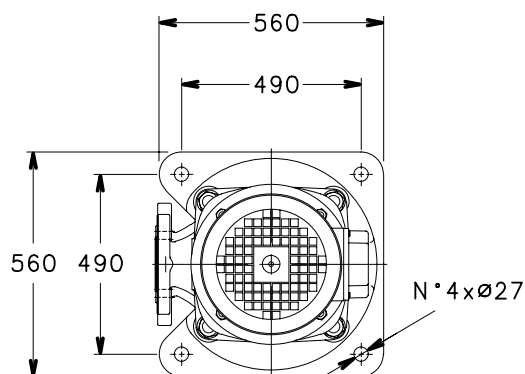
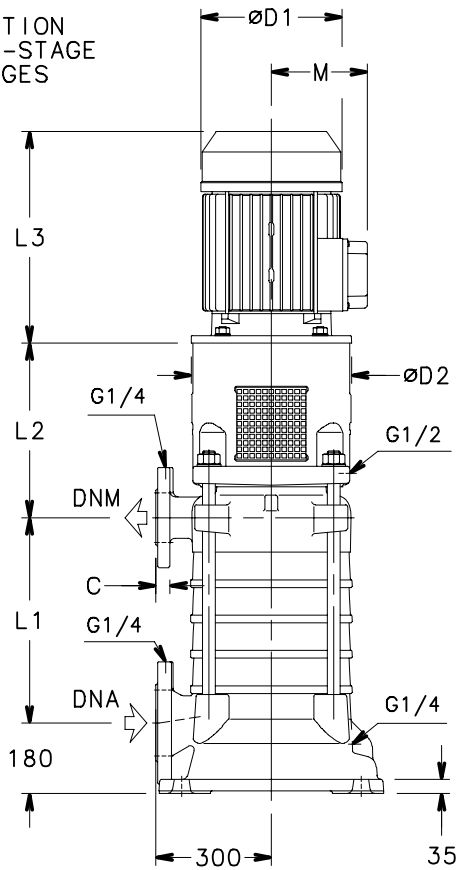

POSITION OF FLANGES UP TO 2 STAGES

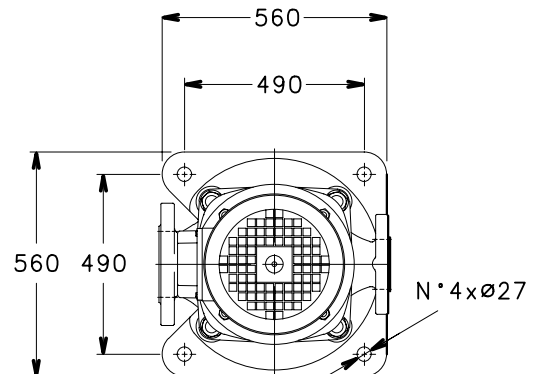
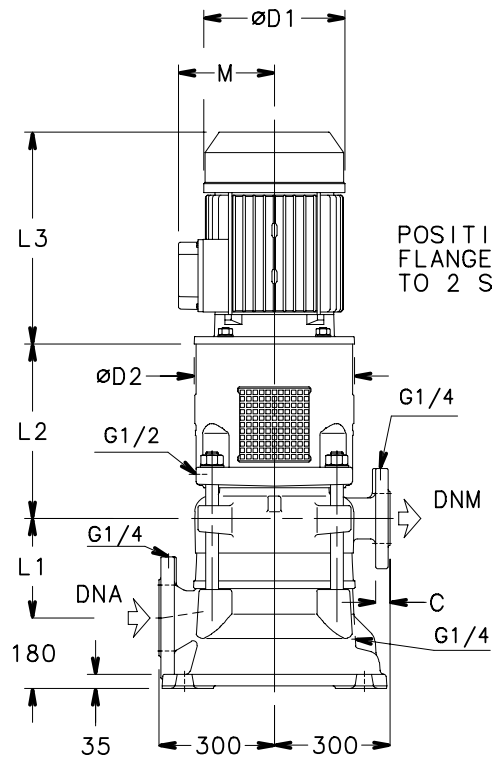

TDV220 SERIES DIMENSIONS AND WEIGHTS AT 50 Hz, 2 POLES

PUMP TYPE	MOTOR		DIMENSIONS (mm)						PN FLANGES		MECH. SEAL TYPE	WEIGHT kg	
	kW	SIZE	L1	L2	L3	D1	D2	M	DNA	DNM		PUMP	ELECTRIC
TDV220 01/1D	45	225	220	597	746	455	450	384	10	16	SA	471	827
TDV220 01/1C	55	250	220	597	825	486	550	402	10	16	SA	479	892
TDV220 01/1B	75	280	220	597	931	599	550	472	10	16	SA	481	1111
TDV220 01/1A	90	280	220	597	931	599	550	472	10	16/40	SA	481	1134
TDV220 02/1C1D	90	280	325	597	931	599	550	472	10	16/40	SA/SB	534	1187
TDV220 02/2C	90	280	325	597	931	599	550	472	10	16/40	SA/SB	534	1187
TDV220 02/1B1C	110	315	325	597	1104	657	660	530	10	40	SA/SB	544	1418
TDV220 02/2B	132	315	325	597	1104	657	660	530	10	40	SA/SB	544	1475
TDV220 02/1A1B	160	315	325	597	1104	657	660	530	10	40	SB	549	1544
TDV220 02/2A	160	315	325	597	1104	657	660	530	10	40	SB	549	1544
TDV220 03/1B2C	160	315	430	597	1104	657	660	530	10	40	SB	602	1597
TDV220 03/2B1C	160	315	430	597	1104	657	660	530	10	40	SB	602	1597
TDV220 03/3B	200	315	430	597	1104	657	660	530	10	40	SB	602	1777
TDV220 03/1A2B	200	315	430	597	1104	657	660	530	10	40	SB	602	1777
TDV220 03/2A1B	250	355	430	597	1272	736	800	625	10	40/63	SB	651	2285
TDV220 03/3A	250	355	430	597	1272	736	800	625	10	40/63	SB	651	2285
TDV220 04/4B	250	355	535	597	1272	736	800	625	10	40/63	SB	704	2338
TDV220 04/1A3B	250	355	535	597	1272	736	800	625	10	63	SB	704	2338
TDV220 04/2A2B	315	355	535	597	1272	736	800	625	10	63	SB	704	2481
TDV220 04/3A1B	315	355	535	597	1272	736	800	625	10	63	SB	704	2481
TDV220 04/4A	315	355	535	597	1272	736	800	625	10	63	SB	704	2481
TDV220 05/1A4B	355	355	640	597	1272	736	800	625	10	63	SB	762	2600
TDV220 05/2A3B	355	355	640	597	1272	736	800	625	10	63	SB	762	2600
TDV220 05/3A2B	355	355	640	597	1272	736	800	625	10	63	SB	762	2600

Weights refer to Version F (Cast Iron)

tdv220-2p50-en_c_td

TDV280 SERIES
DIMENSIONS AND WEIGHTS AT 50 Hz, 2 POLES

PUMP FLANGES

DN	PN	D	M	G	Z	F	C
DNM 125	10/16	279	210	184	8	19	29
	25/40	279	220	184	8	28	29
	63	330	240	184	8	31	35
DNA 150	10/16	300	240	211	8	23	32
	25(*)	300	250	211	8	28	32
	(*) ON REQUEST						

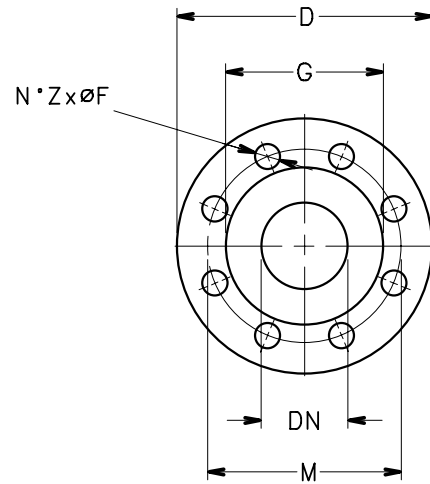

POSITION
OF 3-STAGE
FLANGES

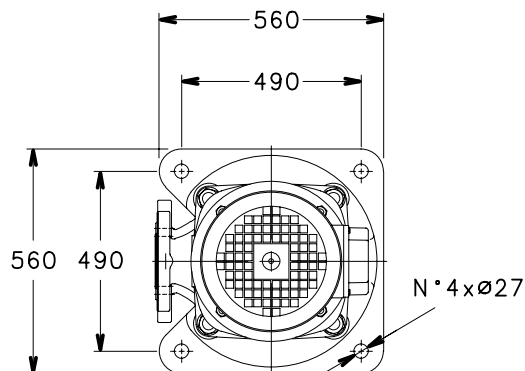
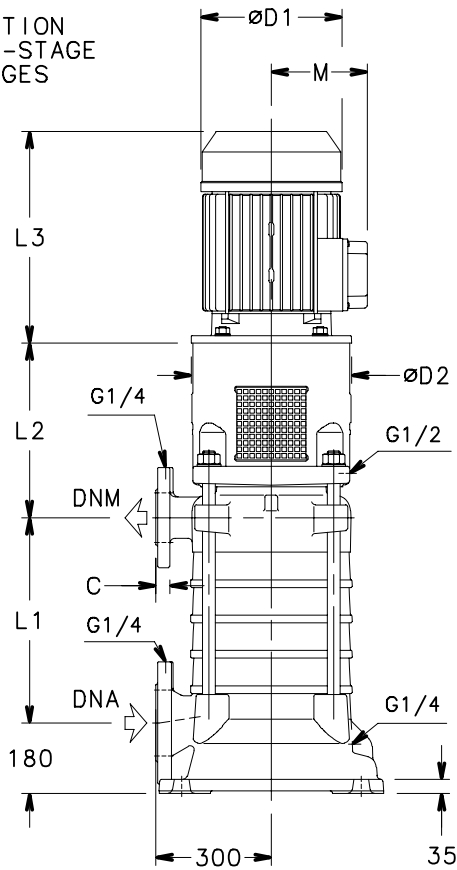

POSITION OF
FLANGES UP
TO 2 STAGES

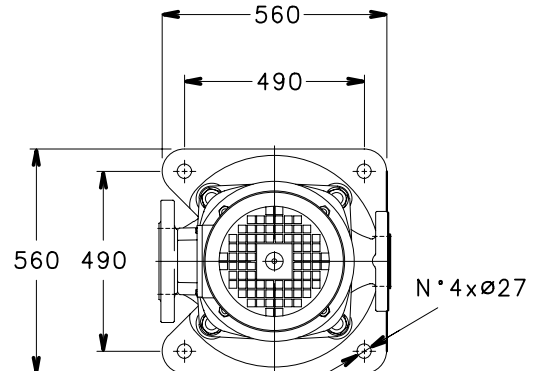
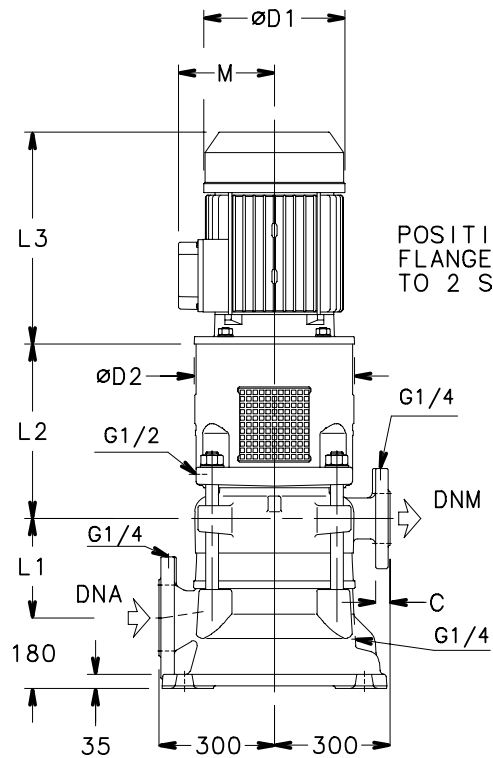

TDV280 SERIES DIMENSIONS AND WEIGHTS AT 50 Hz, 2 POLES

PUMP TYPE	MOTOR		DIMENSIONS (mm)						PN FLANGES		MECH. SEAL TYPE	WEIGHT kg	
	kW	SIZE	L1	L2	L3	D1	D2	M	DNA	DNM		PUMP	ELECTRIC
TDV280 01/1D	45	225	220	597	746	455	450	384	10	16	SA	471	827
TDV280 01/1C	55	250	220	597	825	486	550	402	10	16	SA	479	892
TDV280 01/1B	75	280	220	597	931	599	550	472	10	16	SA	481	1111
TDV280 01/1A	90	280	220	597	931	599	550	472	10	16/40	SA	481	1134
TDV280 02/1C1D	90	280	325	597	931	599	550	472	10	16/40	SA/SB	534	1187
TDV280 02/2C	110	315	325	597	1104	657	660	530	10	16/40	SA/SB	544	1418
TDV280 02/1B1C	110	315	325	597	1104	657	660	530	10	40	SA/SB	544	1418
TDV280 02/2B	132	315	325	597	1104	657	660	530	10	40	SA/SB	544	1475
TDV280 02/1A1B	160	315	325	597	1104	657	660	530	10	40	SB	549	1544
TDV280 02/2A	200	315	325	597	1104	657	660	530	10	40	SB	549	1724
TDV280 03/2B1C	200	315	430	597	1104	657	660	530	10	40	SB	602	1777
TDV280 03/3B	200	315	430	597	1104	657	660	530	10	40	SB	602	1777
TDV280 03/1A2B	250	355	430	597	1272	736	800	625	10	40	SB	651	2285
TDV280 03/2A1B	250	355	430	597	1272	736	800	625	10	40	SB	651	2285
TDV280 03/3A	315	355	430	597	1272	736	800	625	10	40/63	SB	651	2428
TDV280 04/4B	315	355	535	597	1272	736	800	625	10	40/63	SB	704	2481
TDV280 04/1A3B	315	355	535	597	1272	736	800	625	10	40/63	SB	704	2481
TDV280 04/2A2B	315	355	535	597	1272	736	800	625	10	63	SB	704	2481
TDV280 04/3A1B	355	355	535	597	1272	736	800	625	10	63	SB	709	2547
TDV280 04/4A	355	355	535	597	1272	736	800	625	10	63	SB	709	2547
TDV280 05/1A4B	355	355	640	597	1272	736	800	625	10	63	SB	762	2600
TDV280 05/2A3B	355	355	640	597	1272	736	800	625	10	63	SB	762	2600

Weights refer to Version F (Cast Iron)

tdv280-2p50-en_b_td

TDB22..4 - TDB35..4 SERIES
DIMENSIONS AND WEIGHTS AT 50 Hz, 4 POLES

PUMP FLANGES

DN	PN	D	M	G	Z	F	C
DNM 40	10/16	156	110	84	4	19	22
	25/40	156	110	84	4	19	22
	63	178	125	84	4	23	28
DNA 65	10/16	191	145	118	4	19	24
	25(*)	191	145	118	8	19	24
	(*) ON REQUEST						

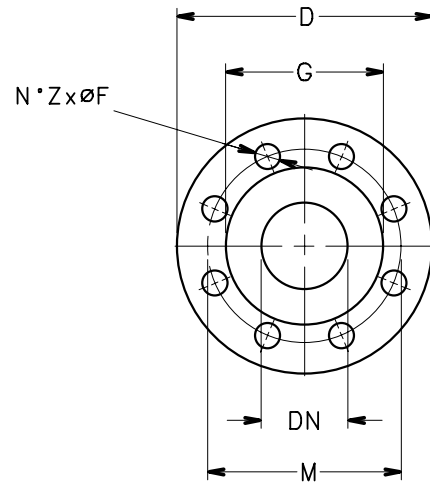

POSITION OF 3-STAGE FLANGES

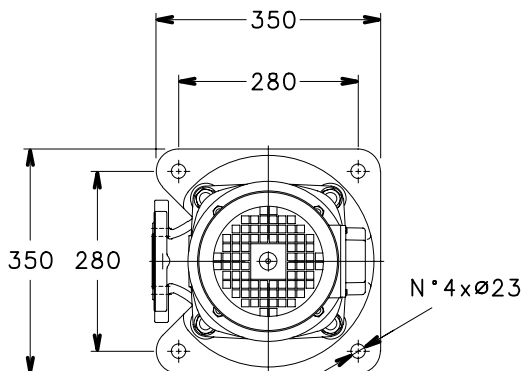
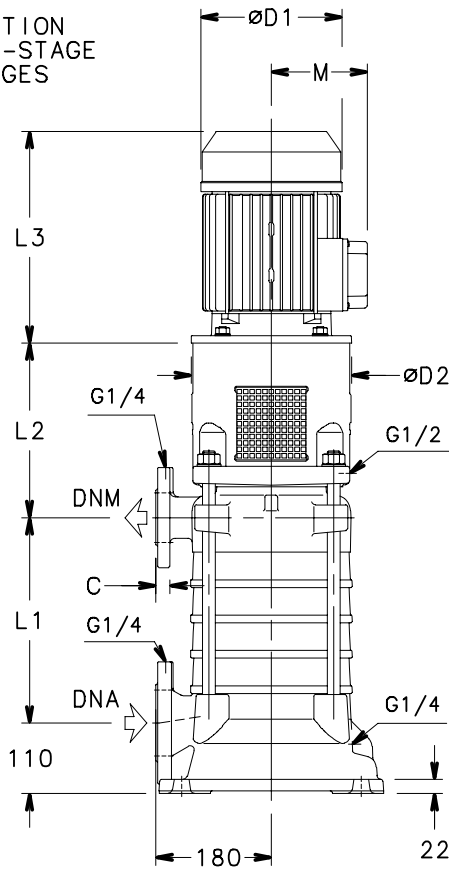

POSITION OF FLANGES UP TO 2 STAGES

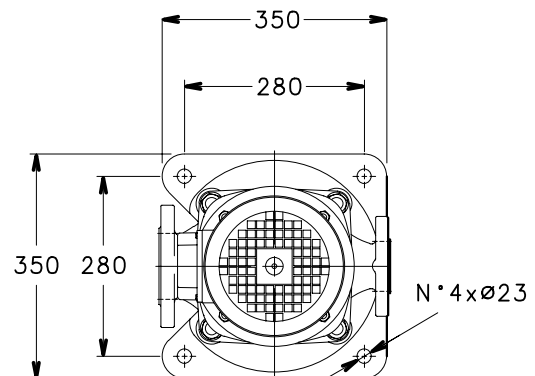
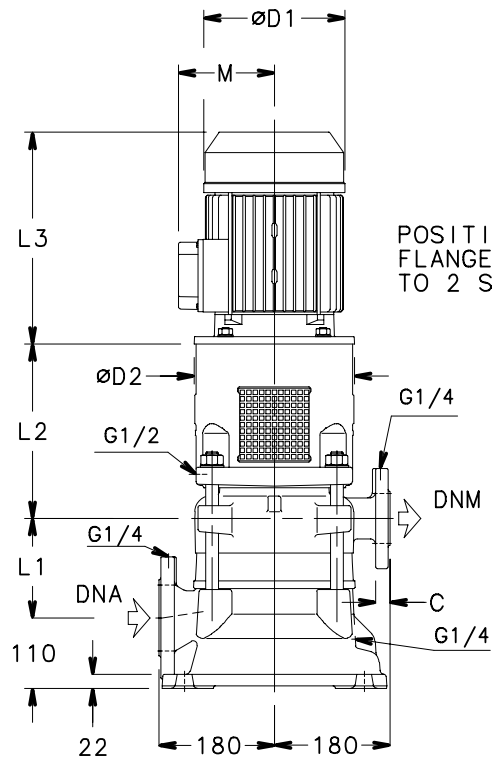

TDB22..4 SERIES DIMENSIONS AND WEIGHTS AT 50 Hz, 4 POLES

PUMP TYPE	MOTOR		DIMENSIONS (mm)						PN FLANGES		MECH. SEAL TYPE	WEIGHT kg	
	kW	SIZE	L1	L2	L3	D1	D2	M	DNA	DNM		PUMP	ELECTRIC PUMP
TDB22 01/1A..4	1,1	90	100	262	298	174	200	134	10	40	SA	91	111
TDB22 02/2A..4	1,1	90	155	262	298	174	200	134	10	40	SA	101	121
TDB22 03/3A..4	1,5	90	210	262	298	174	200	134	10	40	SA	112	135
TDB22 04/4A..4	2,2	100	265	272	322	214	250	168	10	40	SA	122	150
TDB22 05/5A..4	3	100	320	272	353	214	250	168	10	40	SA	133	169
TDB22 06/6A..4	3	100	375	272	353	214	250	168	10	40	SA	143	179
TDB22 07/7A..4	4	112	430	272	398	214	250	168	10	40	SA	154	212
TDB22 08/8A..4	5,5	132	485	292	405	256	300	191	10	40	SA	167	230
TDB22 09/9A..4	5,5	132	540	292	405	256	300	191	10	40	SA	177	240
TDB22 10/10A..4	5,5	132	595	292	405	256	300	191	10	40	SA	188	251
TDB22 11/11A..4	7,5	132	650	292	405	256	300	191	10	40	SA	198	265
TDB22 12/12A..4	7,5	132	705	292	405	256	300	191	10	40	SA	209	276
TDB22 13/13A..4	7,5	132	760	292	405	256	300	191	10	40	SA	219	286
TDB22 14/14A..4	7,5	132	815	292	405	256	300	191	10	40	SA	230	297
TDB22 15/15A..4	11	160	870	322	494	313	350	240	10	40	SA	248	374
TDB22 16/16A..4	11	160	925	322	494	313	350	240	10	40	SA	258	384
TDB22 17/17A..4	11	160	980	322	494	313	350	240	10	40	SB	269	395
TDB22 18/18A..4	11	160	1035	322	494	313	350	240	10	40	SB	279	405

Weights refer to Version F (Cast Iron)

tdb22-4p50-en_b_td

TDB35..4 SERIES DIMENSIONS AND WEIGHTS AT 50 Hz, 4 POLES

PUMP TYPE	MOTOR		DIMENSIONS (mm)						PN FLANGES		MECH. SEAL TYPE	WEIGHT kg	
	kW	SIZE	L1	L2	L3	D1	D2	M	DNA	DNM		PUMP	ELECTRIC PUMP
TDB35 01/1A..4	1,1	90	100	262	298	174	200	134	10	40	SA	91	111
TDB35 02/2A..4	1,5	90	155	262	298	174	200	134	10	40	SA	101	124
TDB35 03/3A..4	2,2	100	210	272	322	214	250	168	10	40	SA	112	140
TDB35 04/4A..4	3	100	265	272	353	214	250	168	10	40	SA	122	158
TDB35 05/5A..4	4	112	320	272	398	214	250	168	10	40	SA	133	191
TDB35 06/6A..4	4	112	375	272	398	214	250	169	10	40	SA	143	201
TDB35 07/7A..4	5,5	132	430	292	405	256	300	191	10	40	SA	156	219
TDB35 08/8A..4	5,5	132	485	292	405	256	300	191	10	40	SA	167	230
TDB35 09/9A..4	7,5	132	540	292	405	256	300	191	10	40	SA	177	244
TDB35 10/10A..4	7,5	132	595	292	405	256	300	191	10	40	SA	188	255
TDB35 11/11A..4	7,5	132	650	292	405	256	300	191	10	40	SA	198	265
TDB35 12/12A..4	11	160	705	322	494	313	350	240	10	40	SA	216	342
TDB35 13/13A..4	11	160	760	322	494	313	350	240	10	40	SA	227	353
TDB35 14/14A..4	11	160	815	322	494	313	350	240	10	40	SA	237	363
TDB35 15/15A..4	11	160	870	322	494	313	350	240	10	40	SA	248	374
TDB35 16/16A..4	11	160	925	322	494	313	350	240	10	40	SA	258	384
TDB35 17/17A..4	15	160	980	322	494	313	350	240	10	40	SB	269	398
TDB35 18/18A..4	15	160	1035	322	494	313	350	240	10	40	SB	279	408

Weights refer to Version F (Cast Iron)

tdb35-4p50-en_b_td

TDB58..4 - TDB78..4 SERIES
DIMENSIONS AND WEIGHTS AT 50 Hz, 4 POLES

PUMP FLANGES

DN	PN	D	M	G	Z	F	C
DNM 65	10/16	191	145	118	4	19	24
	25/40	191	145	118	8	19	24
	63	205	160	118	8	23	28
DNA 100	10/16	235	180	156	8	19	27
	25(*)	235	190	156	8	23	27
(*) ON REQUEST							

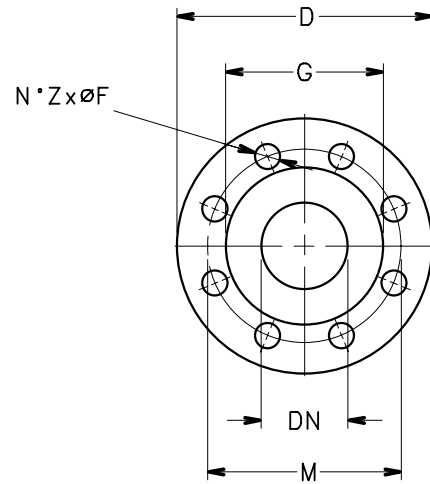

POSITION OF 3-STAGE FLANGES

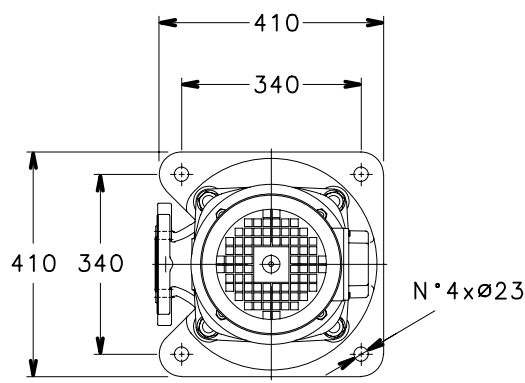
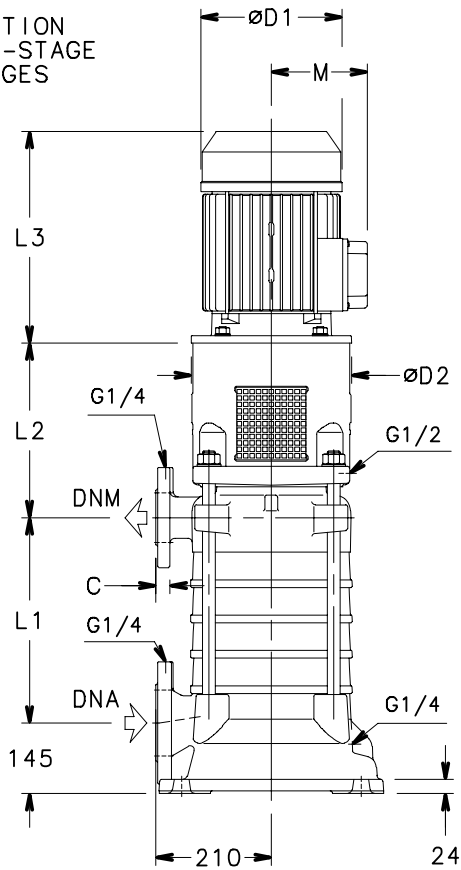

POSITION OF FLANGES UP TO 2 STAGES

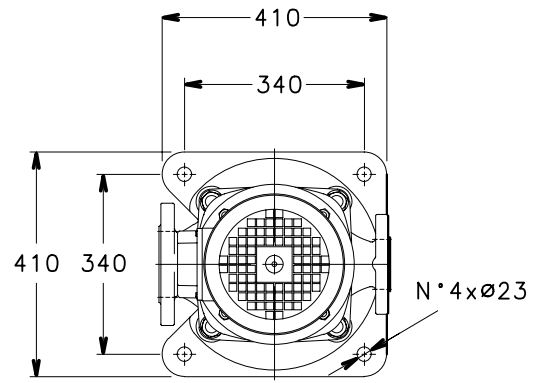
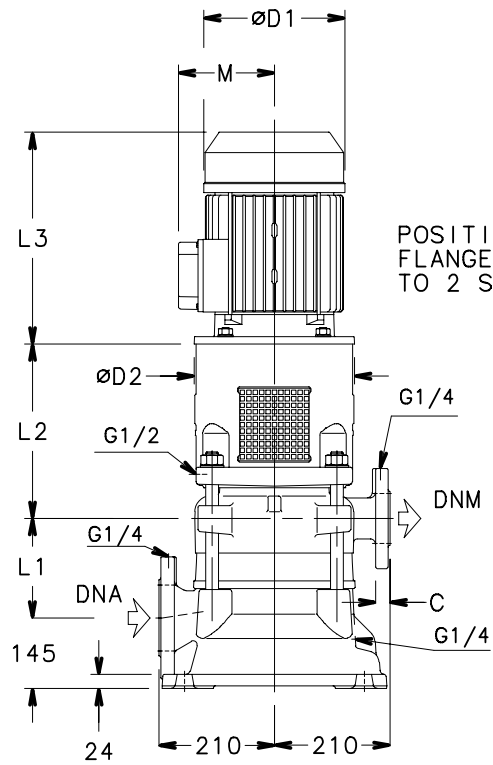

TDB58..4 SERIES DIMENSIONS AND WEIGHTS AT 50 Hz, 4 POLES

PUMP TYPE	MOTOR		DIMENSIONS (mm)						PN FLANGES		MECH. SEAL TYPE	WEIGHT kg	
	kW	SIZE	L1	L2	L3	D1	D2	M	DNA	DNM		PUMP	ELECTRIC
TDB58 01/1A..4	2,2	100	125	291	322	214	250	168	10	16	SA	130	158
TDB58 02/2A..4	3	100	195	291	353	214	250	168	10	16	SA	147	183
TDB58 03/3A..4	4	112	265	291	398	214	250	168	10	16	SA	163	221
TDB58 04/4A..4	5,5	132	335	311	405	256	300	191	10	16	SA	183	246
TDB58 05/5A..4	7,5	132	405	311	405	256	300	191	10	16	SA	199	266
TDB58 06/6A..4	11	160	475	341	494	313	350	240	10	16	SA	226	352
TDB58 07/7A..4	11	160	545	341	494	313	350	240	10	16	SA	242	368
TDB58 08/8A..4	11	160	615	341	494	313	350	240	10	16	SA	259	385
TDB58 09/9A..4	15	160	685	341	494	313	350	240	10	16	SA	275	404
TDB58 10/10A..4	15	160	755	341	494	313	350	240	10	16	SA	292	421
TDB58 11/11A..4	15	160	825	341	494	313	350	240	10	16	SA	308	437
TDB58 12/12A..4	18,5	180	895	341	554	360	350	279	10	40	SB	325	489
TDB58 13/13A..4	18,5	180	965	341	554	360	350	279	10	40	SB	341	505
TDB58 14/14A..4	22	180	1035	341	592	360	350	279	10	40	SB	358	544

Weights refer to Version F (Cast Iron)

tdb58-4p50-en_b_td

TDB78..4 SERIES DIMENSIONS AND WEIGHTS AT 50 Hz, 4 POLES

PUMP TYPE	MOTOR		DIMENSIONS (mm)						PN FLANGES		MECH. SEAL TYPE	WEIGHT kg	
	kW	SIZE	L1	L2	L3	D1	D2	M	DNA	DNM		PUMP	ELECTRIC
TDB78 01/1A..4	2,2	100	125	291	322	214	250	168	10	16	SA	130	158
TDB78 02/2A..4	4	112	195	291	398	214	250	168	10	16	SA	147	205
TDB78 03/3A..4	7,5	132	265	311	405	256	300	191	10	16	SA	166	233
TDB78 04/4A..4	11	160	335	341	494	313	350	240	10	16	SA	193	319
TDB78 05/5A..4	11	160	405	341	494	313	350	240	10	16	SA	209	335
TDB78 06/6A..4	15	160	475	341	494	313	350	240	10	16	SA	226	355
TDB78 07/7A..4	15	160	545	341	494	313	350	240	10	16	SA	242	371
TDB78 08/8A..4	18,5	180	615	341	554	360	350	279	10	16	SA	259	423
TDB78 09/9A..4	18,5	180	685	341	554	360	350	279	10	16	SA	275	439
TDB78 10/10A..4	22	180	755	341	592	360	350	279	10	16	SA	292	478
TDB78 11/11A..4	22	180	825	341	592	360	350	279	10	40	SB	308	494
TDB78 12/12A..4	30	200	895	341	657	402	400	317	10	40	SB	328	550
TDB78 13/13A..4	30	200	965	341	657	402	400	317	10	40	SB	344	566
TDB78 14/14A..4	30	200	1035	341	657	402	400	317	10	40	SB	361	583

Weights refer to Version F (Cast Iron)

tdb78-4p50-en_b_td

TDB120..4 - TDV170..4 SERIES
DIMENSIONS AND WEIGHTS AT 50 Hz, 4 POLES

PUMP FLANGES

DN	PN	D	M	G	Z	F	C
DNM 100	10/16	235	180	156	8	19	27
	25/40	235	190	156	8	23	27
	63	273	200	156	8	28	32
DNA 125	10/16	279	210	184	8	19	29
	25(*)	279	220	184	8	28	29
(*) ON REQUEST							

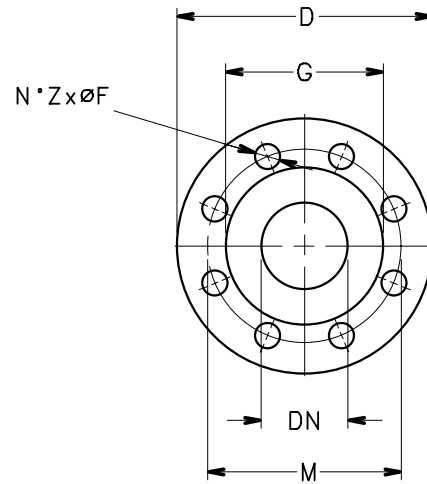

POSITION OF 3-STAGE FLANGES

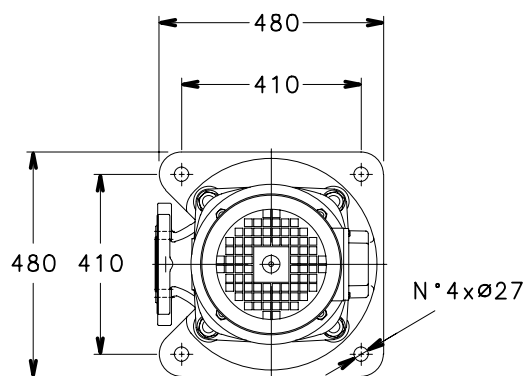
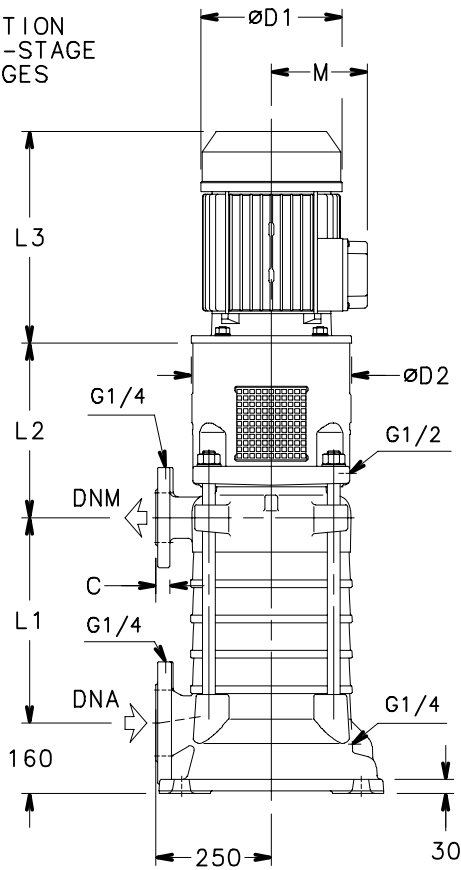

POSITION OF FLANGES UP TO 2 STAGES

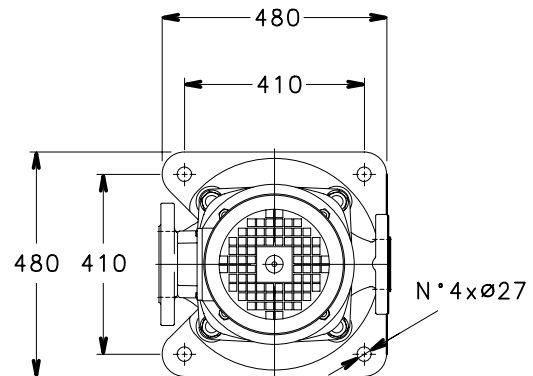
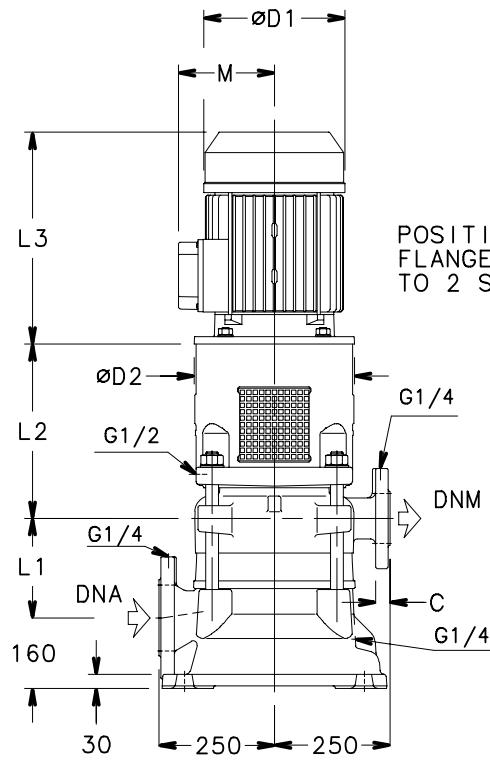

TDB120..4 SERIES DIMENSIONS AND WEIGHTS AT 50 Hz, 4 POLES

PUMP TYPE	MOTOR		DIMENSIONS (mm)						PN FLANGES		MECH. SEAL TYPE	WEIGHT kg	
	kW	SIZE	L1	L2	L3	D1	D2	M	DNA	DNM		PUMP	ELECTRIC
TDB120 01/1C..4	11	160	175	371	494	313	350	240	10	16	SA	270	396
TDB120 01/1B..4	11	160	175	371	494	313	350	240	10	16	SA	270	396
TDB120 01/1A..4	11	160	175	371	494	313	350	240	10	16	SA	270	396
TDB120 02/2B..4	11	160	260	371	494	313	350	240	10	16	SA	302	428
TDB120 02/2A..4	11	160	260	371	494	313	350	240	10	16	SA	302	428
TDB120 03/1A2B..4	15	160	345	371	494	313	350	240	10	16	SA	334	463
TDB120 03/3A..4	15	160	345	371	494	313	350	240	10	16	SA	334	463
TDB120 04/2A2B..4	18,5	180	430	371	554	360	350	279	10	16	SA	366	530
TDB120 04/4A..4	18,5	180	430	371	554	360	350	279	10	16	SA	366	530
TDB120 05/3A2B..4	22	180	515	371	592	360	350	279	10	16	SA	398	584
TDB120 05/5A..4	22	180	515	371	592	360	350	279	10	16	SA	398	584
TDB120 06/4A2B..4	30	200	600	371	657	402	400	317	10	16	SA	431	653
TDB120 06/6A..4	30	200	600	371	657	402	400	317	10	16	SA	431	653
TDB120 07/5A2B..4	30	200	685	371	657	402	400	317	10	16	SA	463	685
TDB120 07/7A..4	37	225	685	401	746	455	450	384	10	16	SA	468	810
TDB120 08/6A2B..4	37	225	770	401	746	455	450	384	10	40	SB	500	842
TDB120 08/8A..4	37	225	770	401	746	455	450	384	10	40	SB	500	842
TDB120 09/7A2B..4	45	225	855	401	746	455	450	384	10	40	SB	532	895
TDB120 09/9A..4	45	225	855	401	746	455	450	384	10	40	SB	532	895
TDB120 10/8A2B..4	45	225	940	401	746	455	450	384	10	40	SB	564	927
TDB120 10/10A..4	45	225	940	401	746	455	450	384	10	40	SB	564	927

Weights refer to Version F (Cast Iron)

tdb120-4p50-en_c_td

TDV170..4 SERIES DIMENSIONS AND WEIGHTS AT 50 Hz, 4 POLES

PUMP TYPE	MOTOR		DIMENSIONS (mm)						PN FLANGES		MECH. SEAL TYPE	WEIGHT kg	
	kW	SIZE	L1	L2	L3	D1	D2	M	DNA	DNM		PUMP	ELECTRIC
TDB170 01/1C..4	11	160	175	371	494	313	350	240	10	16	SA	270	396
TDB170 01/1B..4	11	160	175	371	494	313	350	240	10	16	SA	270	396
TDB170 01/1A..4	11	160	175	371	494	313	350	240	10	16	SA	270	396
TDB170 02/2B..4	11	160	260	371	494	313	350	240	10	16	SA	302	428
TDB170 02/2A..4	11	160	260	371	494	313	350	240	10	16	SA	302	428
TDB170 03/1A2B..4	15	160	345	371	494	313	350	240	10	16	SA	334	463
TDB170 03/3A..4	18,5	180	345	371	554	360	350	279	10	16	SA	334	498
TDB170 04/2A2B..4	22	180	430	371	592	360	350	279	10	16	SA	366	552
TDB170 04/4A..4	30	200	430	371	657	402	400	317	10	16	SA	367	589
TDB170 05/3A2B..4	30	200	515	371	657	402	400	317	10	16	SA	399	621
TDB170 05/5A..4	30	200	515	371	657	402	400	317	10	16	SA	399	621
TDB170 06/4A2B..4	37	225	600	401	746	455	450	384	10	16	SA	436	778
TDB170 06/6A..4	37	225	600	401	746	455	450	384	10	16	SA	436	778
TDB170 07/5A2B..4	37	225	685	401	746	455	450	384	10	16	SA	468	810
TDB170 07/7A..4	45	225	685	401	746	455	450	384	10	40	SB	468	831
TDB170 08/6A2B..4	45	225	770	401	746	455	450	384	10	40	SB	500	863
TDB170 08/8A..4	55	250	770	401	825	486	550	402	10	40	SB	503	947
TDB170 09/7A2B..4	55	250	855	401	825	486	550	402	10	40	SB	535	979
TDB170 09/9A..4	55	250	855	401	825	486	550	402	10	40	SB	535	979
TDB170 10/8A2B..4	55	250	940	401	825	486	550	402	10	40	SB	567	1011
TDV170 10/10A..4	75	280	940	514	931	599	550	472	10	40	SB	611	1250

Weights refer to Version F (Cast Iron)

tdb-tdv170-4p50-en_b_td

TDV220..4 - TDV280..4 SERIES
DIMENSIONS AND WEIGHTS AT 50 Hz, 4 POLES

PUMP FLANGES

DN	PN	D	M	G	Z	F	C
DNM 125	10/16	279	210	184	8	19	29
	25/40	279	220	184	8	28	29
	63	330	240	184	8	31	35
DNA 150	10/16	300	240	211	8	23	32
	25(*)	300	250	211	8	28	32
(*) ON REQUEST							

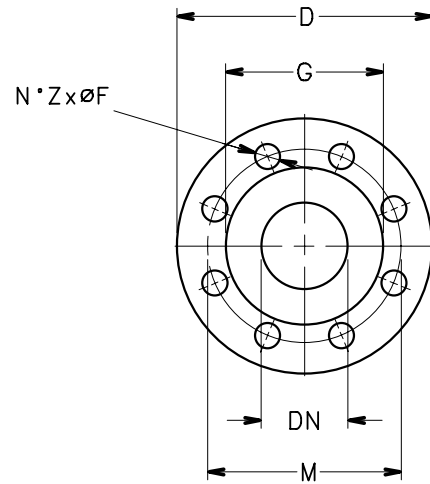

POSITION
OF 3-STAGE
FLANGES

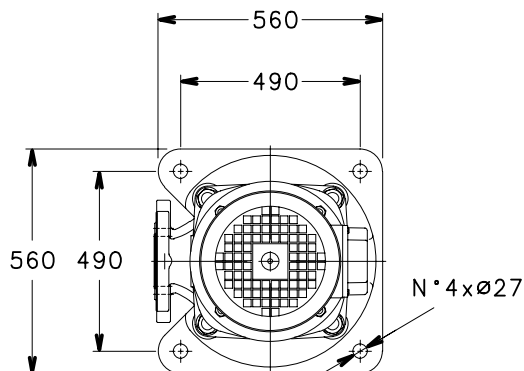
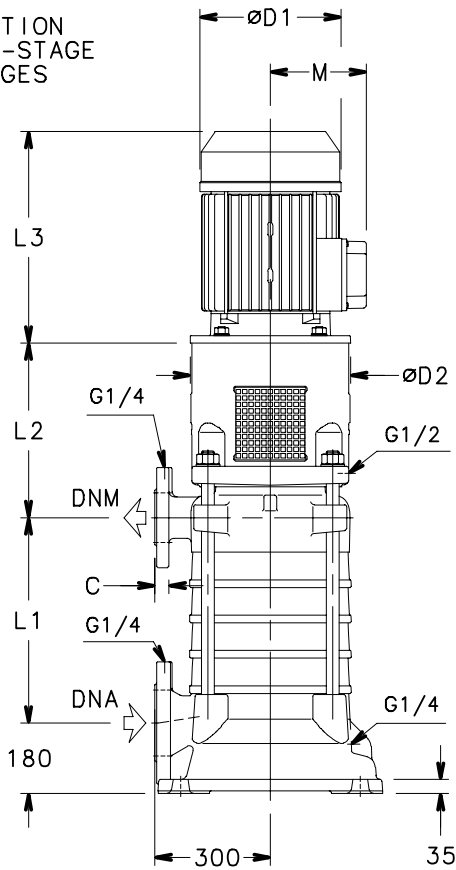

POSITION OF
FLANGES UP
TO 2 STAGES

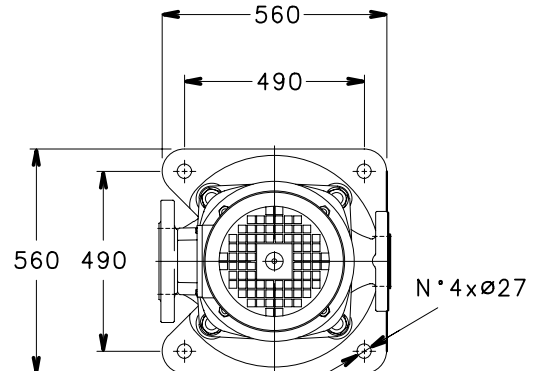
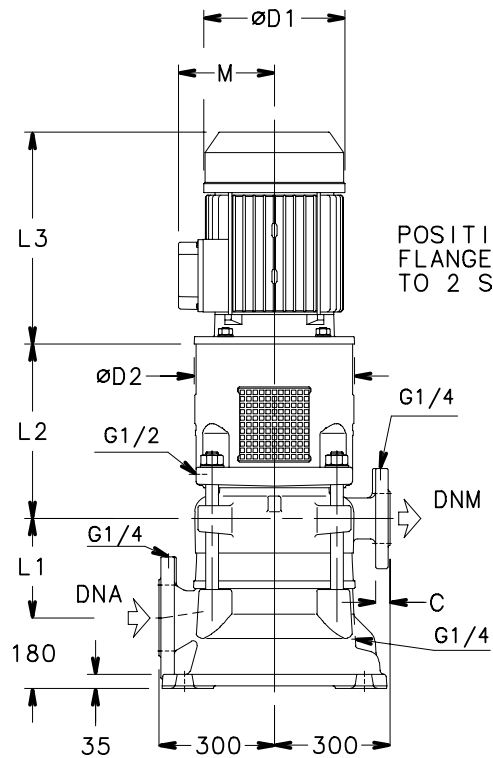

TDV220..4 SERIES

DIMENSIONS AND WEIGHTS AT 50 Hz, 4 POLES

PUMP TYPE	MOTOR		DIMENSIONS (mm)						PN FLANGES		MECH. SEAL TYPE	WEIGHT kg	
	kW	SIZE	L1	L2	L3	D1	D2	M	DNA	DNM		PUMP	ELECTRIC
TDV220 01/1C..4	11	160	220	567	494	313	350	240	10	16	SA	461	587
TDV220 01/1B..4	11	160	220	567	494	313	350	240	10	16	SA	461	587
TDV220 01/1A..4	11	160	220	567	494	313	350	240	10	16	SA	461	587
TDV220 02/2B..4	15	160	325	567	494	313	350	240	10	16	SA	514	643
TDV220 02/2A..4	22	180	325	567	592	360	350	279	10	16	SA	514	700
TDV220 03/1A2B..4	30	200	430	567	657	402	400	317	10	16	SA	569	791
TDV220 03/3A..4	30	200	430	567	657	402	400	317	10	16	SA	569	791
TDV220 04/2A2B..4	37	225	535	597	746	455	450	384	10	16	SA	631	973
TDV220 04/4A..4	45	225	535	597	746	455	450	384	10	16	SA	631	994
TDV220 05/3A2B..4	45	225	640	597	746	455	450	384	10	16	SA	684	1047
TDV220 05/5A..4	55	250	640	597	825	486	400	402	10	16	SA	693	1137
TDV220 06/4A2B..4	55	250	745	597	825	486	450	402	10	40	SB	746	1190
TDV220 06/6A..4	75	280	745	597	931	599	550	472	10	40	SB	751	1390
TDV220 07/5A2B..4	75	280	850	597	931	599	550	472	10	40	SB	804	1443
TDV220 07/7A..4	75	280	850	597	931	599	550	472	10	40	SB	804	1443
TDV220 08/6A2B..4	75	280	955	597	931	599	550	472	10	40	SB	857	1496
TDV220 08/8A..4	90	280	955	597	931	599	550	472	10	40	SB	857	1530

Weights refer to Version F (Cast Iron)

tdv220-4p50-en_b_td

TDV280..4 SERIES

DIMENSIONS AND WEIGHTS AT 50 Hz, 4 POLES

PUMP TYPE	MOTOR		DIMENSIONS (mm)						PN FLANGES		MECH. SEAL TYPE	WEIGHT kg	
	kW	SIZE	L1	L2	L3	D1	D2	M	DNA	DNM		PUMP	ELECTRIC
TDV280 01/1C..4	11	160	220	567	494	313	350	240	10	16	SA	461	587
TDV280 01/1B..4	11	160	220	567	494	313	350	240	10	16	SA	461	587
TDV280 01/1A..4	11	160	220	567	494	313	350	240	10	16	SA	461	587
TDV280 02/2B..4	18,5	180	325	567	554	360	350	279	10	16	SA	514	678
TDV280 02/2A..4	22	180	325	567	592	360	350	279	10	16	SA	514	700
TDV280 03/1A2B..4	30	200	430	567	657	402	400	317	10	16	SA	569	791
TDV280 03/3A..4	37	225	430	597	746	455	450	384	10	16	SA	578	920
TDV280 04/2A2B..4	45	225	535	597	746	455	450	384	10	16	SA	631	994
TDV280 04/4A..4	45	225	535	597	746	455	450	384	10	16	SA	631	994
TDV280 05/3A2B..4	55	250	640	597	825	486	550	402	10	16	SA	693	1137
TDV280 05/5A..4	55	250	640	597	825	486	550	402	10	16	SA	693	1137
TDV280 06/4A2B..4	75	280	745	597	931	599	550	472	10	40	SB	751	1390
TDV280 06/6A..4	75	280	745	597	931	599	550	472	10	40	SB	751	1390
TDV280 07/5A2B..4	75	280	850	597	931	599	550	472	10	40	SB	804	1443
TDV280 07/7A..4	90	280	850	597	931	599	550	472	10	40	SB	804	1477
TDV280 08/6A2B..4	90	280	955	597	931	599	550	472	10	40	SB	857	1530
TDV280 08/8A..4	90	280	955	597	931	599	550	472	10	40	SB	857	1530

Weights refer to Version F (Cast Iron)

tdv280-4p50-en_b_td

TECHNICAL APPENDIX

**TDB - TDV SERIES
PRESSURE / TEMPERATURE RANGES (EN 1092-2)
MAXIMUM PERMITTED WORKING PRESSURE (BODY AND
FLANGES)**

DIAGRAM FOR VERSIONS F, FB (FN)

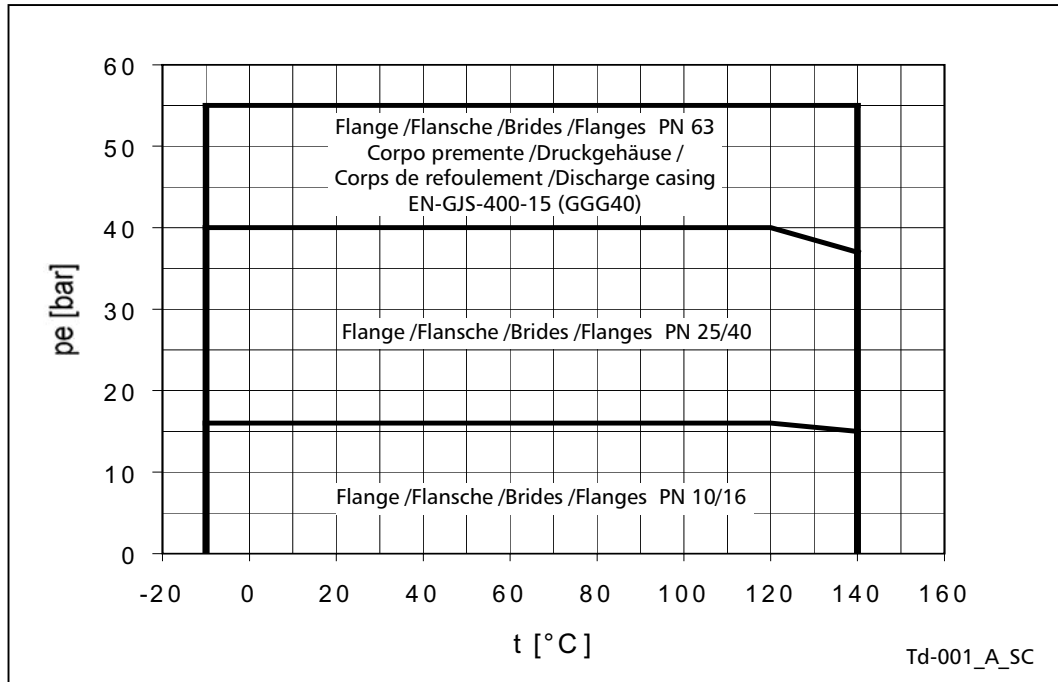
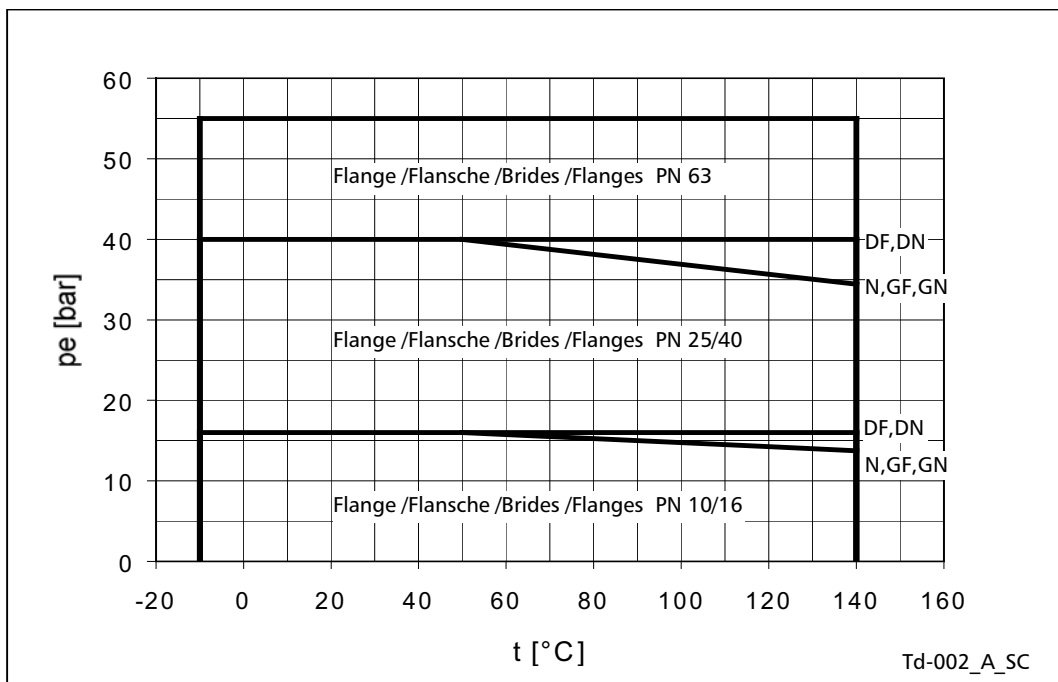

DIAGRAM FOR VERSIONS N (DF, DN, GF, GN)



MAXIMUM PERMITTED WORKING TEMPERATURE $P_e =$
PUMP INLET PRESSURE (SUCTION SIDE) + HEAD AT $Q=0$ m³/h

TDB - TDV SERIES FORCES AND MOMENTS ON SUCTION AND DELIVERY SIDE SLEEVES

F_x : direct force along x-axis (pump shaft).

F_y, F_z : direct forces along y- and z-axis.

M_x : moment around x-axis.

M_y, M_z : moment around y- and z-axis.

The forces and moment indicated in the table, as well as their respective sums, must not be exceeded.

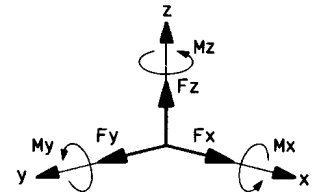

$$\Sigma F = \sqrt{(F_x^2 + F_y^2 + F_z^2)} \quad [N] \quad \Sigma M = \sqrt{(M_x^2 + M_y^2 + M_z^2)} \quad [Nm]$$

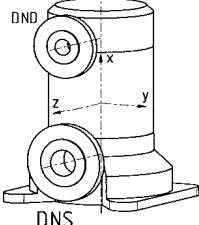
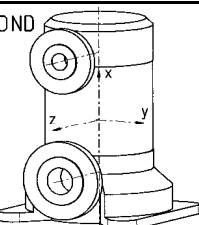
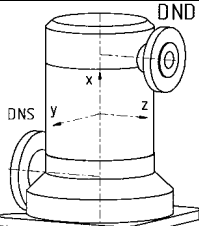
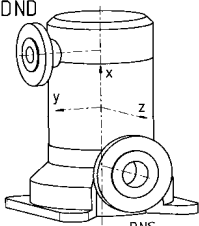
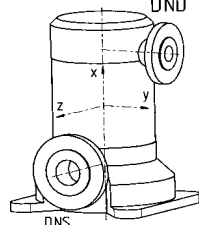
PUMP TYPE		TDB22 TDB35	TDB58 TDB78	TDB/TDV120 TDB/TDV170	TDB220 TDB280
PERMITTED FORCES AND MOMENTS ON DNS SUCTION SLEEVES					
	F_x	560	900	1130	1350
	F_y	510	810	1010	1220
	F_z	620	1010	1250	1500
	ΣF	980	1580	1970	2360
	M_x	350	440	570	700
	M_y	200	260	350	440
	M_z	260	330	440	540
	ΣM	480	610	800	990
PERMITTED FORCES AND MOMENTS ON DND SUCTION SLEEVES					
	F_x	330	560	900	1130
	F_y	300	510	810	1010
	F_z	380	620	1010	1250
	ΣF	590	980	1580	1970
	M_x	280	350	440	570
	M_y	140	200	260	350
	M_z	190	260	330	440
	ΣM	370	480	610	800
	F_x	330	560	900	1130
	F_y	300	510	810	1010
	F_z	380	620	1010	1250
	ΣF	590	980	1580	1970
	M_x	280	350	440	570
	M_y	140	200	260	350
	M_z	190	260	330	440
	ΣM	370	480	610	800
	F_x	330	560	900	1130
	F_y	380	620	1010	1250
	F_z	300	510	810	1010
	ΣF	590	980	1580	1970
	M_x	280	350	440	570
	M_y	140	200	260	350
	M_z	190	260	330	440
	ΣM	370	480	610	800
	F_x	330	560	900	1130
	F_y	380	620	1010	1250
	F_z	300	510	810	1010
	ΣF	590	980	1580	1970
	M_x	280	350	440	570
	M_y	140	200	260	350
	M_z	190	260	330	440
	ΣM	370	480	610	800

td_forze-en_a_td

TDB - TDV SERIES FORCES AND MOMENTS ON SUCTION AND DELIVERY SIDE SLEEVES

The Forces and Moments applied must respect the following relationship:

$$(\sum F \text{ calculated} / \sum F_{\text{max, permitted}})^2 + (\sum M \text{ calculated} / \sum M_{\text{max, permitted}})^2 \leq 2$$

This relationship must be checked if the load on one of the sleeves exceeds the values indicated in the table.

TDB - TDV SERIES RATING PLATE

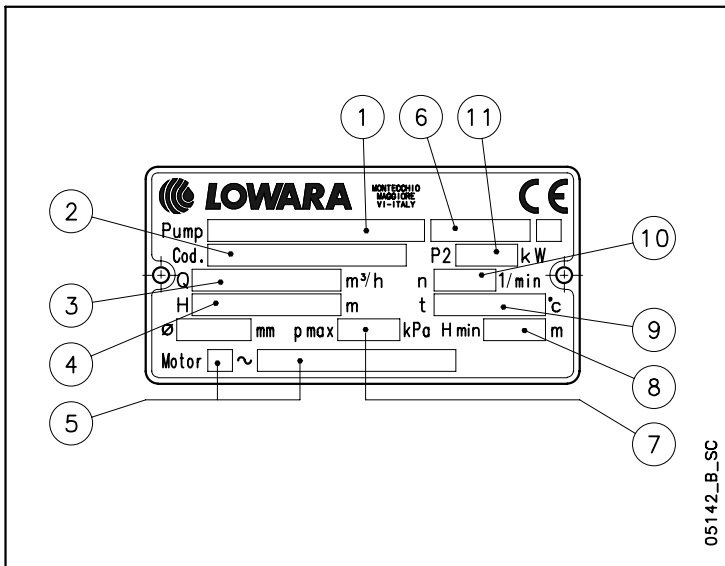

LEGEND

- 1 - Electric pump type
- 2 - Code
- 3 - Delivery range
- 4 - Head range
- 5 - Motor type
- 6 - Serial number
- 7 - Maximum operating pressure
- 8 - Minimum head
- 9 - Maximum operating temperature
- 10 - Speed
- 11 - Rated power

TDB SERIES MOMENTS OF INERTIA

PUMP TYPE	NUMBER OF STAGES	MOMENTS OF INERTIA (WITH COUPLING) I [Kgm ²]					
		CAST IRON IMPELLER (GG25)		BRONZE IMPELLER (G-CuSn10)		STAINLESS STEEL IMPELLER (AISI CF8M)	
		Without water	Filled with water	Without water	Filled with water	Without water	Filled with water
TDB22 TDB35	1	0,0112	0,0119	0,0120	0,0127	0,0115	0,0122
	2	0,0152	0,0166	0,0168	0,0182	0,0158	0,0172
	3	0,0191	0,0212	0,0215	0,0236	0,0200	0,0221
	4	0,0230	0,0258	0,0262	0,0290	0,0242	0,0270
	5	0,0270	0,0305	0,0310	0,0345	0,0285	0,0320
	6	0,0309	0,0351	0,0357	0,0399	0,0327	0,0369
	7	0,0349	0,0398	0,0405	0,0454	0,0370	0,0419
	8	0,0388	0,0444	0,0452	0,0508	0,0412	0,0468
	9	0,0427	0,0490	0,0499	0,0562	0,0454	0,0517
	10	0,0467	0,0537	0,0547	0,0617	0,0497	0,0567
	11	0,0506	0,0583	0,0594	0,0671	0,0539	0,0616
	12	0,0545	0,0629	0,0641	0,0725	0,0581	0,0665
	13	0,0585	0,0676	0,0689	0,078	0,0624	0,0715
	14	0,0624	0,0722	0,0736	0,0834	0,0666	0,0764
	15	0,0663	0,0768	0,0783	0,0888	0,0708	0,0813
	16	0,0703	0,0815	0,0831	0,0943	0,0751	0,0863
	17	0,0742	0,0861	0,0878	0,0997	0,0793	0,0912
	18	0,0781	0,0907	0,0925	0,1051	0,0835	0,0961
TDB58 TDB78	1	0,0155	0,0176	0,0173	0,0191	0,0162	0,0180
	2	0,0240	0,0276	0,0270	0,0306	0,0248	0,0284
	3	0,0322	0,0376	0,0367	0,0421	0,0334	0,0388
	4	0,0404	0,0476	0,0464	0,0536	0,0420	0,0492
	5	0,0486	0,0576	0,0561	0,0651	0,0506	0,0596
	6	0,0567	0,0675	0,0657	0,0765	0,0591	0,0699
	7	0,0649	0,0775	0,0754	0,088	0,0677	0,0803
	8	0,0731	0,0875	0,0851	0,0995	0,0763	0,0907
	9	0,0813	0,0975	0,0948	0,111	0,7860	0,1011
	10	0,0895	0,1075	0,1045	0,1225	0,0935	0,1115
	11	0,0976	0,1174	0,1141	0,1339	0,1020	0,1218
	12	0,1058	0,1274	0,1238	0,1454	0,1106	0,1322
	13	0,1140	0,1374	0,1335	0,1569	0,1192	0,1426
	14	0,1222	0,1474	0,1432	0,1684	0,1278	0,1530
TDB120 TDB170	1	0,0351	0,0409	0,0405	0,0463	0,0371	0,0429
	2	0,0625	0,0741	0,0733	0,0849	0,0665	0,0781
	3	0,0898	0,1072	0,1060	0,1234	0,0958	0,1132
	4	0,1172	0,1404	0,1388	0,162	0,1252	0,1484
	5	0,1446	0,1736	0,1716	0,2006	0,1546	0,1836
	6	0,1719	0,2067	0,2043	0,2391	0,1839	0,2187
	7	0,1993	0,2399	0,2371	0,2777	0,2133	0,2539
	8	0,2267	0,2731	0,2699	0,3163	0,2427	0,2891
	9	0,2540	0,3062	0,3026	0,3548	0,2720	0,3242
	10	0,2814	0,3394	0,3354	0,3934	0,3014	0,3594

tdb_momenti-en_a_td

TDV SERIES MOMENTS OF INERTIA

PUMP TYPE	NUMBER OF STAGES	MOMENTS OF INERTIA (WITH COUPLING I [Kgm ²])					
		CAST IRON IMPELLER (GG25)		BRONZE IMPELLER (G-CuSn10)		STAINLESS STEEL IMPELLER (AISI CF8M)	
		Without water	Filled with water	Without water	Filled with water	Without water	Filled with water
TDV120 TDV170	1	0,0287	0,0345	0,0341	0,0399	0,0307	0,0365
	2	0,0561	0,0677	0,0669	0,0785	0,0601	0,0717
	3	0,0835	0,1009	0,0997	0,1171	0,0895	0,1069
	4	0,1108	0,1340	0,1324	0,1556	0,1188	0,1420
	5	0,1382	0,1672	0,1652	0,1942	0,1482	0,1772
	6	0,1656	0,2004	0,198	0,2328	0,1776	0,2124
	7	0,1929	0,2335	0,2307	0,2713	0,2069	0,2475
	8	0,2203	0,2667	0,2635	0,3099	0,2363	0,2827
	9	0,2477	0,2999	0,2963	0,3485	0,2657	0,3179
	10	0,2750	0,3330	0,3290	0,3870	0,2950	0,3530
TDV220 TDV280	1	0,0574	0,0691	0,0692	0,0809	0,0629	0,0746
	2	0,1107	0,1341	0,1343	0,1577	0,1217	0,1451
	3	0,1640	0,1991	0,1994	0,2345	0,1805	0,2156
	4	0,2173	0,2641	0,2645	0,3113	0,2393	0,2861
	5	0,2706	0,3291	0,3296	0,3881	0,2981	0,3566
	6	0,3239	0,3941	0,3947	0,4649	0,3569	0,4271
	7	0,3773	0,4592	0,4599	0,5418	0,4158	0,4977
	8	0,4306	0,5242	0,5250	0,6186	0,4746	0,5682

tdv_momenti-en_a_td

TDB - TDV SERIES MECHANICAL SEAL SELECTION DIAGRAM, API-Plan 1 (11)

TAB.1 : LIMIT CURVES (depending on pump hydraulics and motor speed).

PUMP TYPE	MOTOR	
	1450 min ⁻¹	2950 min ⁻¹
TDB22 TDB35	1	2
TDB58 TDB78	1	2
TDB-TDV120 TDB-TDV170	1	3
TDV220 TDV280	2	3

td_diag1-en_a_td

DIAG.1 : PRESSURE-TEMPERATURE DIAGRAM FOR MECHANICAL SEAL SELECTION

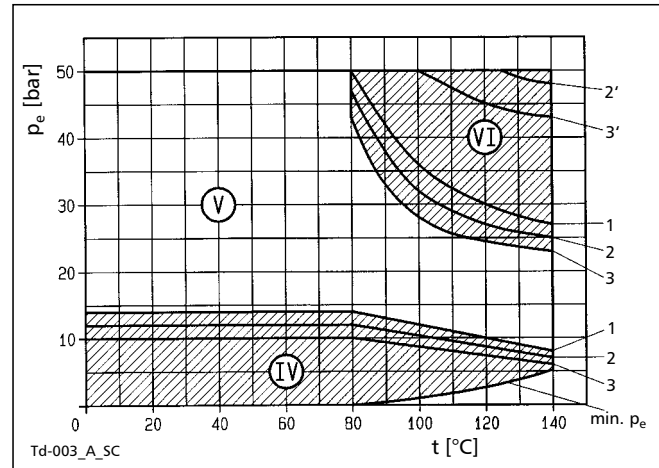

TAB.2 : TYPE OF MECHANICAL SEAL

AREA	TYPE OF MECHANICAL SEAL
IV	SA (UNBALANCED) Max 16 bar
V	SB (BALANCED) Max 55 bar
VI	SPECIAL VERSION Only on request

td_diag2-en_a_td

LEGEND

- min Pe: minimum pressure on mechanical seal.
- 2' , 3': maximum permitted pressure on mechanical seal.
- 1 , 2 , 3: pressure-temperature separation curves between areas IV, V, VI.

$$P_e = P_z + (P_p / j) \times (j - 1) \text{ [bar]}$$

where:

P_z = inlet pressure of suction side [bar].

P_p = maximum pump head [bar], for $Q = 0 \text{ m}^3/\text{h}$ corresponding to the number of stages j .

j = number of stages.

TDB - TDV SERIES

MECHANICAL SEAL SELECTION DIAGRAM, API-Plan 1 (11)

The calculated value of P_e [bar] together with water temperature (°C), identifies a point which lies in one of the 3 areas (IV, V, VI) indicated in diagram 1.

Table 2 shows the most suitable seal.

GENERAL CONSIDERATIONS:

These diagrams and selection tables are valid for clean water (only < 10 mg/l) or water for feeding boilers, partially or totally demineralised.

If the water temperature exceeds 80 °C , minimum inlet pressure must be guaranteed.

If the selection falls in area VI, please contact your local sales office.

SELECTION EXAMPLE:

Electric pump: Lowara TDB 3507/7A, motor 37 kw , 2p , 50 Hz

Liquid: clean water at 60 °C.

Pressure of system at pump inlet $P_z = 3$ bar.

- A) TAB.1 shows that the limit curve is curve 2.
This curve defines the separation limit between areas IV and V and between areas V and VI.
- B) $P_e = P_z + (P_p / j) \times (j - 1)$ where $P_z = 3$ bar , $P_p = 28$ bar , $j = 7$
of which $P_e = 3 + (28 / 7) \times 6 = 27$ bar.
- C) From DIAG.1, with $P_e = 27$ bar (y-axis) and $T = 60$ °C (x-axis) ,
the point of intersection lies in area V.
- D) TAB.2 shows that the most suitable seal is SB (Balanced).

**TDB - TDV SERIES
FIXING BOLTS AND TORQUE SETTING**

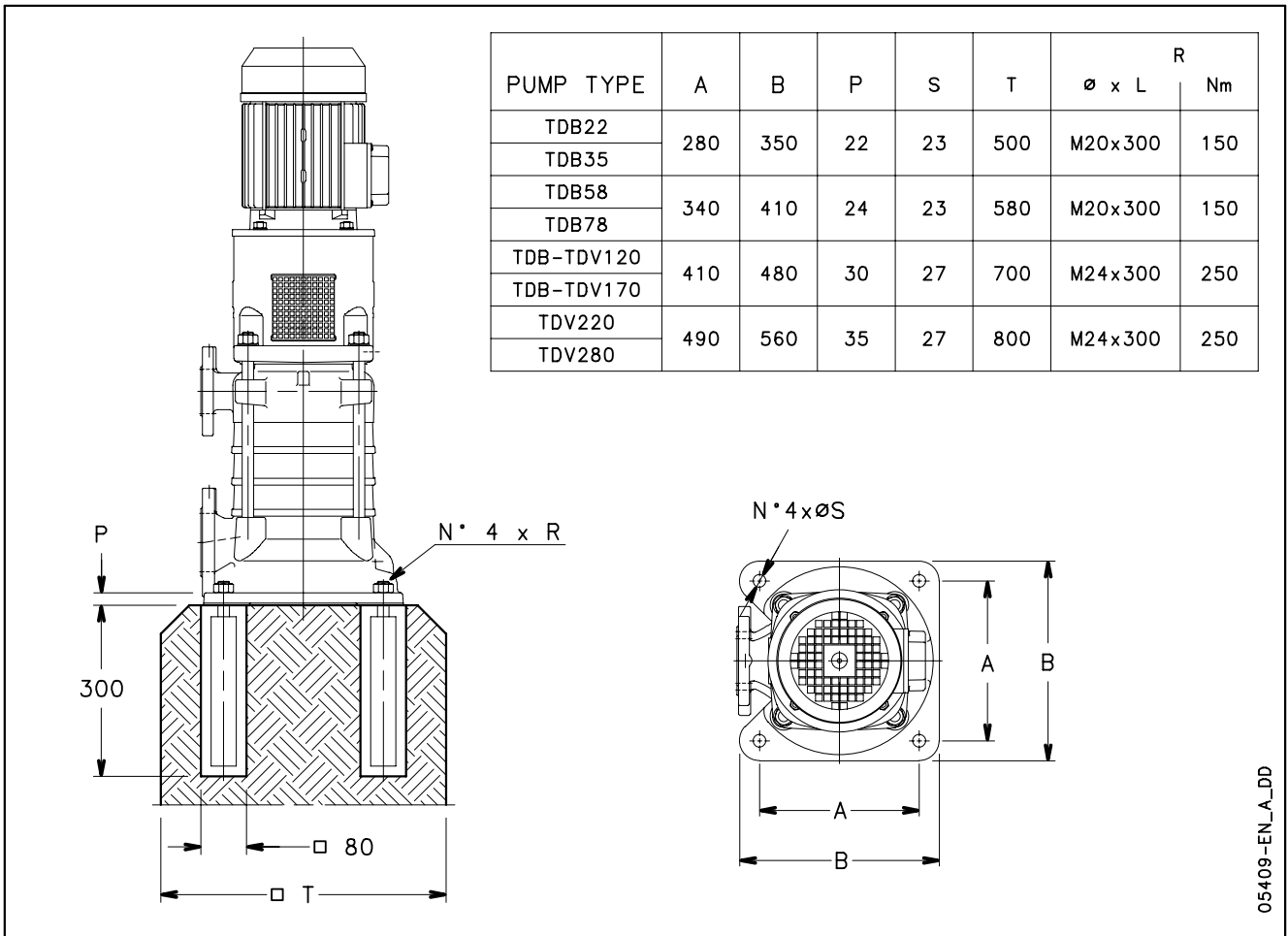

05409-EN_A_DD

FURTHER PRODUCT SELECTION AND DOCUMENTATION

Xylect

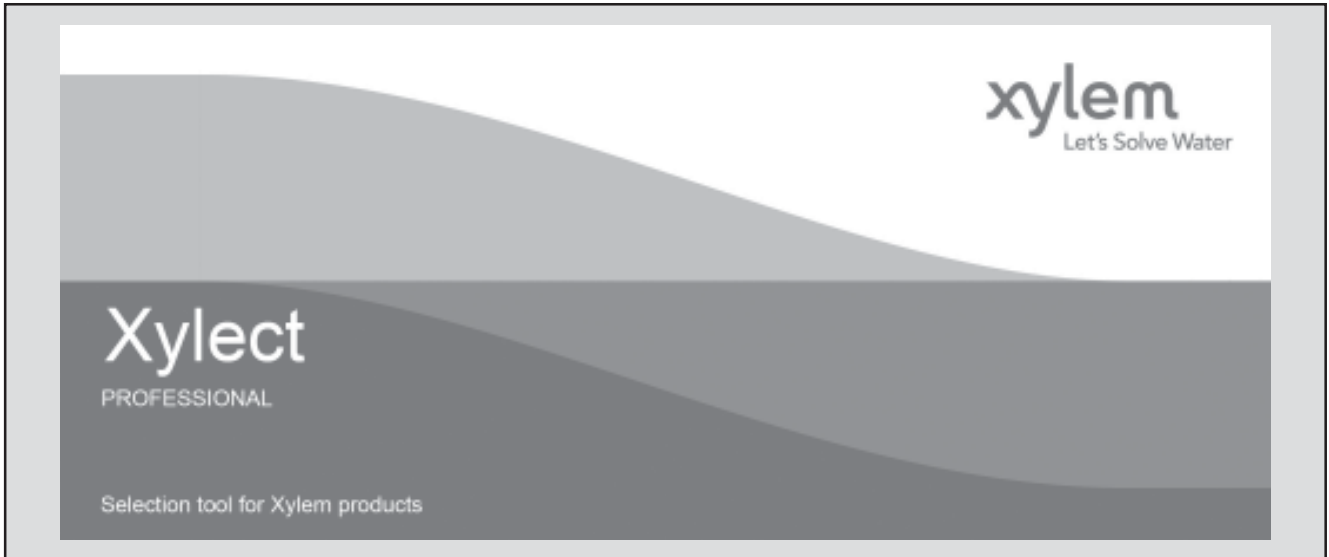

Xylect is pump solution selection software with an extensive online database of product information across the entire Lowara, and Vogel range of pumps and related products, with multiple search options and helpful project management facilities. The system holds up-to-date product information on thousands of products and accessories.

The possibility to search by applications and the detailed information output given makes it easy to make the optimal selection without having detailed knowledge about the Lowara and Vogel products.

The search can be made by:

- Application
- Product type
- Duty point

Xylect gives a detailed output:

- List with search results
- Performance curves (flow, head, power, efficiency, NPSH)
- Motor data
- Dimensional drawings
- Options
- Data sheet printouts
- Document downloads incl dxf files

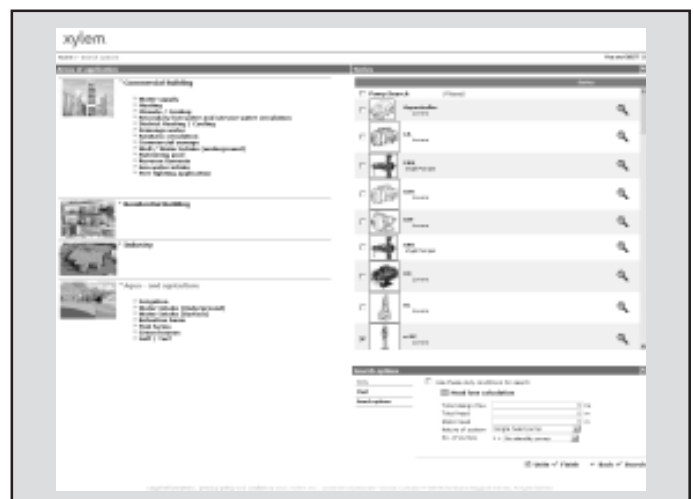

The search by application guides users not familiar with the product range to the right choice.

FURTHER PRODUCT SELECTION AND DOCUMENTATION

Xylect

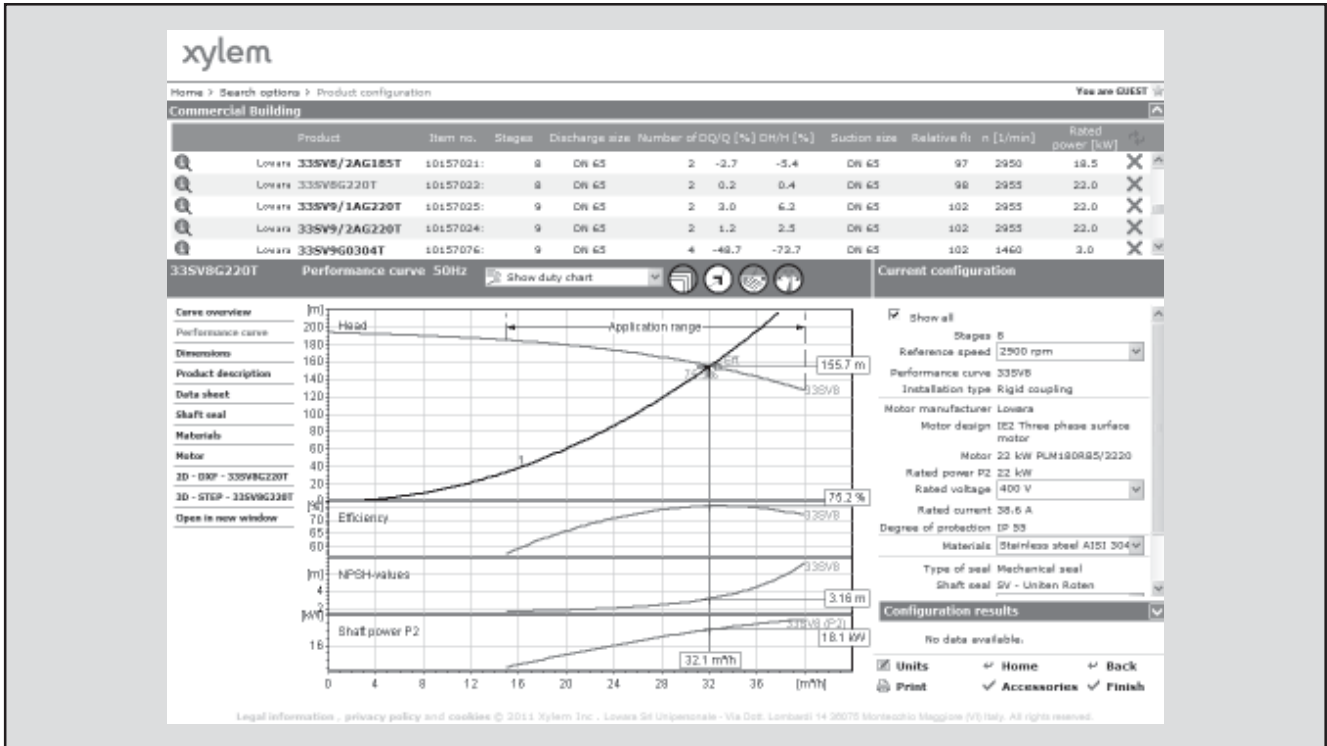

The detailed output makes it easy to select the optimal pump from the given alternatives.

The best way to work with Xylect is to create a personal account. This makes it possible to:

- Set own standard units
- Create and save projects
- Share projects with other Xylect users

Every user has a My Xylect space, where all projects are saved.

For more information about Xylect please contact our sales network or visit www.xylect.com.

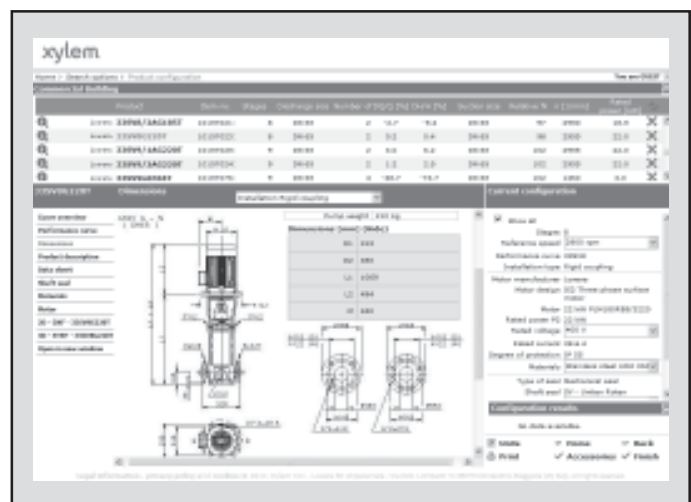

Dimensional drawings appear on the screen and can be downloaded in dxf format.

Xylem |'zīləm|

- 1) The tissue in plants that brings water upward from the roots;
- 2) a leading global water technology company.

We're 12,000 people unified in a common purpose: creating innovative solutions to meet our world's water needs. Developing new technologies that will improve the way water is used, conserved, and re-used in the future is central to our work. We move, treat, analyze, and return water to the environment, and we help people use water efficiently, in their homes, buildings, factories and farms. In more than 150 countries, we have strong, long-standing relationships with customers who know us for our powerful combination of leading product brands and applications expertise, backed by a legacy of innovation.

For more information on how Xylem can help you, go to xylem.com.



Headquarters

LOWARA S.r.l. Unipersonale

Via Lombardi 14

36075 Montecchio Maggiore - Vicenza - Italy

Tel. (+39) 0444 707111 - Fax (+39) 0444 492166

e-mail: lowara.mkt@xylem.com

web: www.lowara.com - www.completewatersystems.com

LOWARA reserves the right to make modification without prior notice.
LOWARA is a trademark of Xylem Inc. or one of its subsidiaries.