



Компания ПромХимТех-  
официальный дистрибьютор  
насосов Flowserve  
[www.promhimtech.ru](http://www.promhimtech.ru)  
Тел. 8 800 250-01-54  
e-mail: [zakaz@promhimtech.ru](mailto:zakaz@promhimtech.ru)

## ***PolyChem™ Non-Metallic Chemical Process Pumps***

***ASME and ISO***

***M-Series***

***S-Series***

***GRP***

***VGRP***

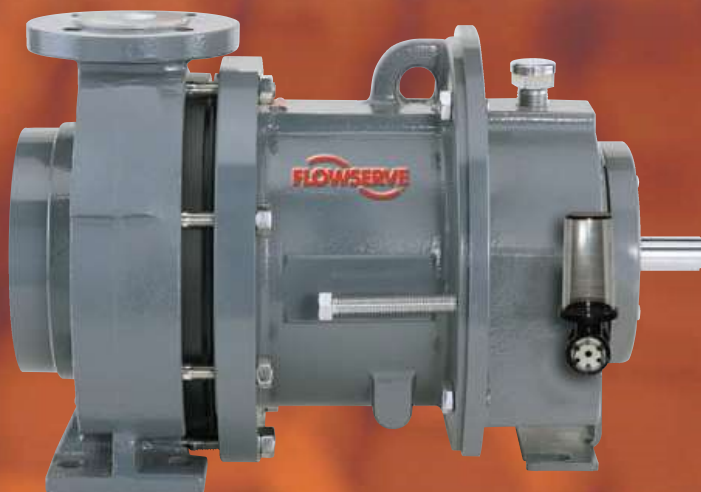

## Pump Supplier To The World

*Flowserve is the driving force in the global industrial pump marketplace. No other pump company in the world has the depth or breadth of expertise in the successful application of pre-engineered, engineered and special purpose pumps and systems.*

### Pumping Solutions

Flowserve is providing pumping solutions which permit customers to continuously improve productivity, profitability and pumping system reliability.

### Market Focused Customer Support

Product and industry specialists develop effective proposals and solutions directed toward market and customer preferences. They offer technical advice and assistance throughout each stage of the product life cycle, beginning with the inquiry.



### Dynamic Technologies

Flowserve is without peer in the development and application of pump technology, including:

- Hydraulic engineering
- Mechanical design
- Materials science
- Intelligent pumping
- Manufacturing technology

### Broad Product Lines

Flowserve offers a wide range of complementary pump types, from pre-engineered process pumps, to highly engineered and special purpose pumps and systems. Pumps are built to recognized global standards and customer specifications.

Pump designs include:

- Single stage process
- Between bearing single stage
- Between bearing multistage
- Vertical
- Submersible motor
- Rotary
- Reciprocating
- Nuclear
- Specialty

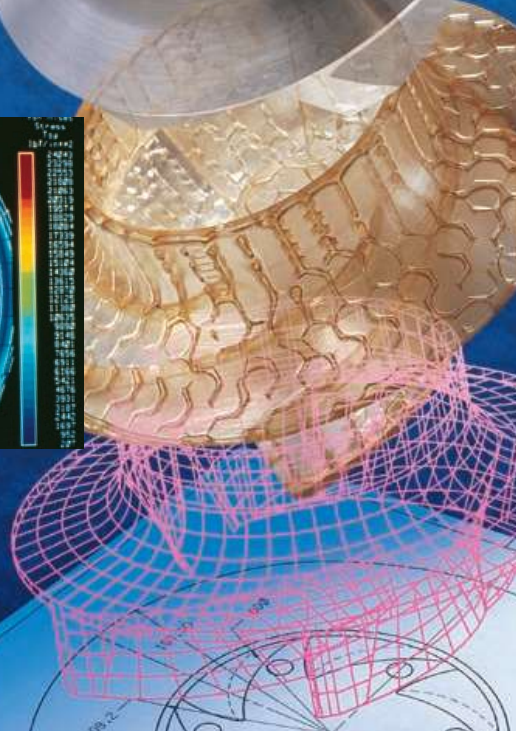
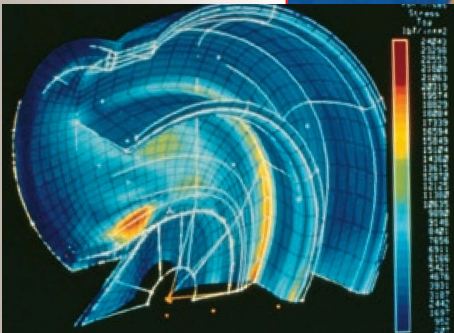
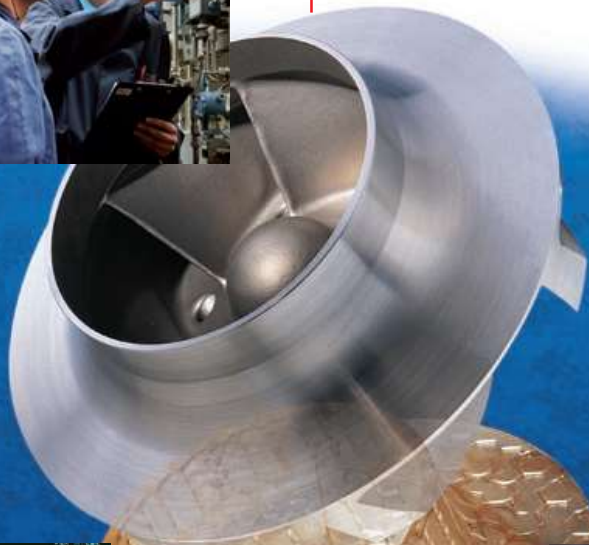

**PolyChem  
Non-Metallic  
Chemical Process  
Pumps**

**Non-Metallic Pumps Designed to Global Standards**

Embracing a global approach to pump design, Flowserve offers sealed and sealless PolyChem non-metallic pumps engineered to ASME and ISO design criteria and to JIS drilling specifications. The fluoropolymer lined M-Series and S-Series pumps and the GRP engineered polymer composite pump are well suited for highly corrosive applications in the worldwide process industries.

**Applications**

- Chemical plants
- Steel and primary metals industry
- Marine environments
- Wastewater treatment
- Aquariums
- Mining works
- Microchip manufacturing

**Complementary Pump Designs**

- Mark 3 ASME metallic chemical process pump
- Mark 3 ASME in-line chemical process pump
- CPX ISO metallic chemical process pump

**Table of Contents**

**PolyChem M-Series**

PFA Lined Sealless Pumps.....4-8  
ASME and ISO Performance Curves ..... 9

**PolyChem S-Series**

PFA Lined Mechanically Sealed Pumps .....10-11  
Sealing Options .....12  
ASME and ISO Performance Curves .... 13

**PolyChem GRP and VGRP Pumps**

Engineered Composite Pumps.....14-16  
ASME Performance Curves ..... 17

**Baseplates and Pump Accessories**

Baseplates .....18-19  
ClearGuard™ .....20  
DurcoShield™ .....20  
Power Monitor .....20  
PROS+.....20

**Other Pumps and General Information**

CPXS and Guardian Magnetic Drive Pumps.....21  
CPX ISO Pumps .....21  
Mark 3 ASME Standard Pumps .....22  
Mark 3 ASME In-Line Pumps.....22

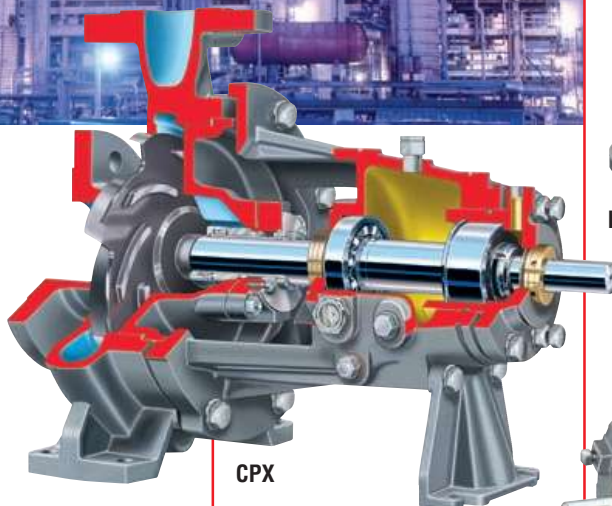

CPX

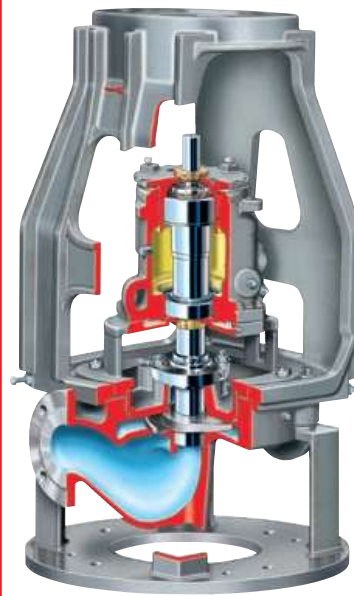

Mark 3 In-Line

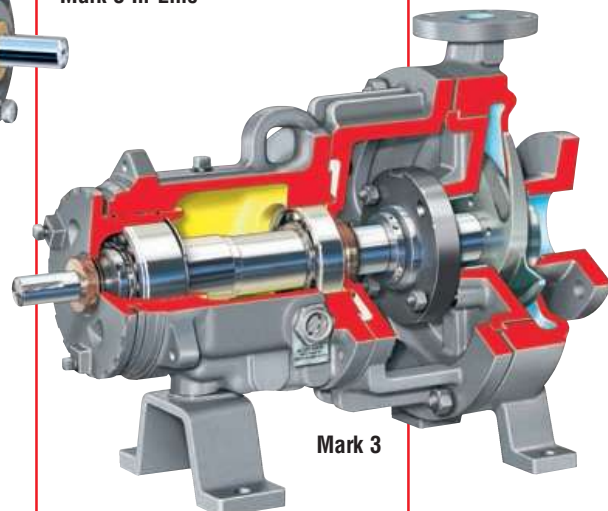

Mark 3

**PolyChem M-Series  
Fluoropolymer Lined  
Sealless Pumps  
Close Coupled**

**Worldwide Application**

The PolyChem M-Series fluoropolymer lined, close coupled, magnetically driven, chemical process pump is the result of extensive global market research. M-Series sealless pumps are rugged, heavy-duty pumps designed specifically for reliable, leak-free performance in demanding process applications.

Addressing customer needs around the globe, PolyChem M-Series pumps meet the following dimensional standards:

- ASME B73.1
- ISO 2858
- JIS drilling

**Operating Parameters**

- Flows to 135 m<sup>3</sup>/h (600 gpm)
- Heads to 145 m (480 ft)
- Pressures to 17 bar (250 psi)
- Temperatures from -30°C (-20°F) to 150°C (300°F)

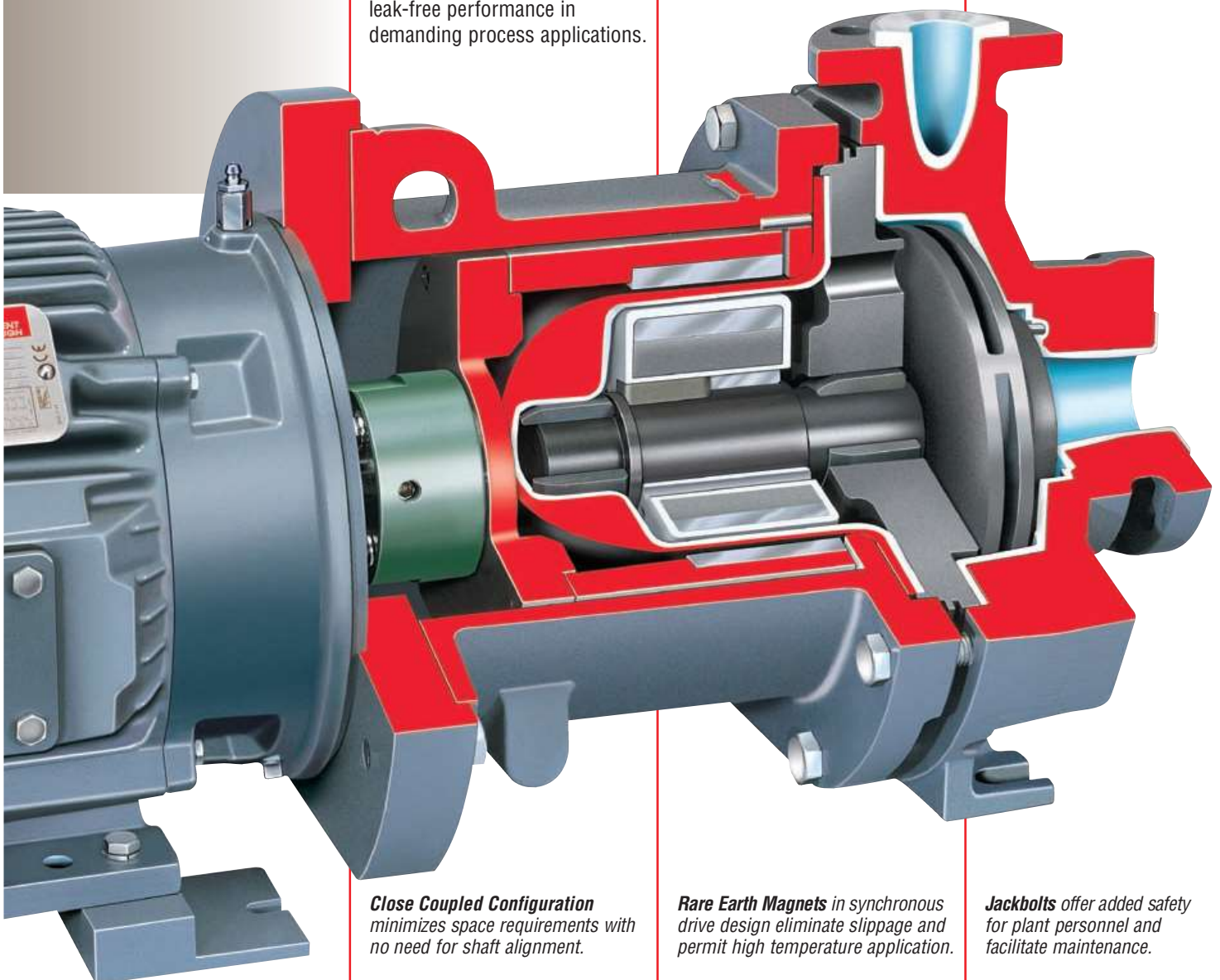

**Close Coupled Configuration** minimizes space requirements with no need for shaft alignment.

**Fluoropolymer Lined Fiberglass Containment Shell** offers superior corrosion resistance and strength.

**Fluoropolymer PFA Lined Wet End** is globally preferred for its superior corrosion resistance and temperature allowance. PFA is carbon reinforced where required for stiffness and strength.

**Rare Earth Magnets** in synchronous drive design eliminate slippage and permit high temperature application.

**Separate Inner Magnet and Impeller Components** result in low cost maintenance and ease of upgrade.

**Rugged Silicon Carbide Radial and Axial Thrust Bearings** offer outstanding wear resistance and chemical inertness.

**Jackbolts** offer added safety for plant personnel and facilitate maintenance.

**Back Pull-Out Design** allows for pump removal without disturbing the casing.

**Non-Sparking Rub Pads** prevent contact of critical components in the unlikely event of outer magnet support bearing failure.

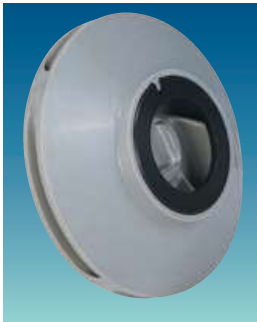

**Enclosed Lined Impeller** provides balanced hydraulic loads, extending bearing life.

**Rugged Design with the Customer in Mind**

PolyChem M-Series pumps were designed to offer the optimum in pump reliability and value, while maintaining a simple design for safety and ease of maintenance.

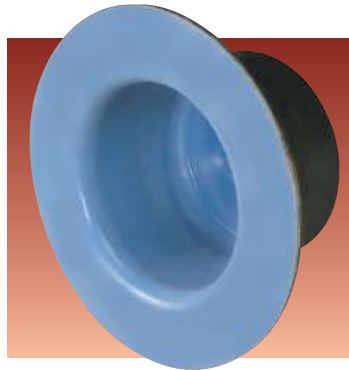

**PFA Lined Casing**

The Flowserve proprietary PFA molding processes ensure liner integrity.

- Ductile cast iron armor has a minimum PFA liner thickness of 3 mm (0.125 in)
- Armor meets ASTM A395 and GGG40.3 specifications

**PFA Lined Fiberglass Containment Shell**

is rated to 17 bar (250 psi) and offers excellent magnet efficiencies. Non-metallic construction eliminates magnetic losses and heat generation associated with metallic containment shells. The result is a more energy-efficient pump that uses a smaller motor and is less likely to cause vaporization of the pumping fluid.



**Large Silicon Carbide Rotating Shaft Offers**

ruggedness simply not found in other non-metallic pumps. PolyChem's rotating shaft is supported by silicon carbide bearings located securely in a reinforced fluoropolymer bearing holder, thereby eliminating the need for bearing support in the inlet of the pump.

**Standard Silicon Carbide Radial and Axial Thrust Bearings**

are chemically inert and have exceptional wear resistance.

**Simplicity in Design**

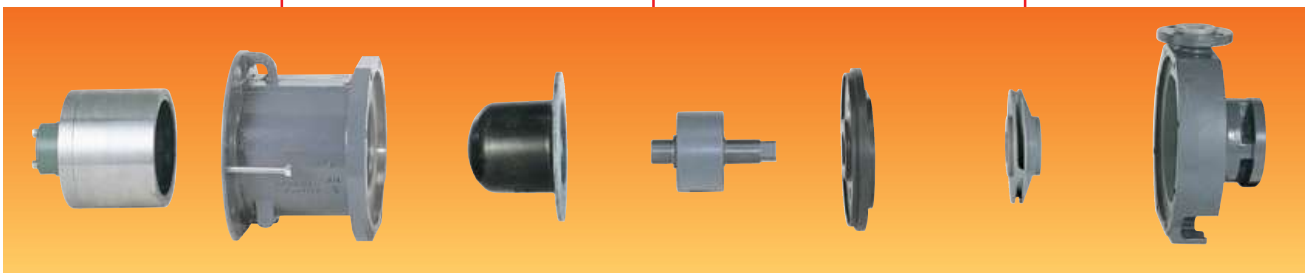

**PolyChem M-Series  
Fluoropolymer Lined  
Sealless Pumps  
Long Coupled**

**Worldwide Application**

The PolyChem M-Series fluoropolymer lined, long coupled, magnetically driven, chemical process pump is the result of extensive global market research. M-Series sealless pumps are rugged, heavy-duty pumps designed specifically for reliable, leak-free performance in demanding process applications.

Addressing customer needs around the globe, PolyChem M-Series pumps meet the following dimensional standards:

- ASME B73.1
- ISO 2858
- JIS drilling

**Operating Parameters**

- Flows to 135 m<sup>3</sup>/h (600 gpm)
- Heads to 145 m (480 ft)
- Pressures to 17 bar (250 psi)
- Temperatures from -30°C (-20°F) to 150°C (300°F)

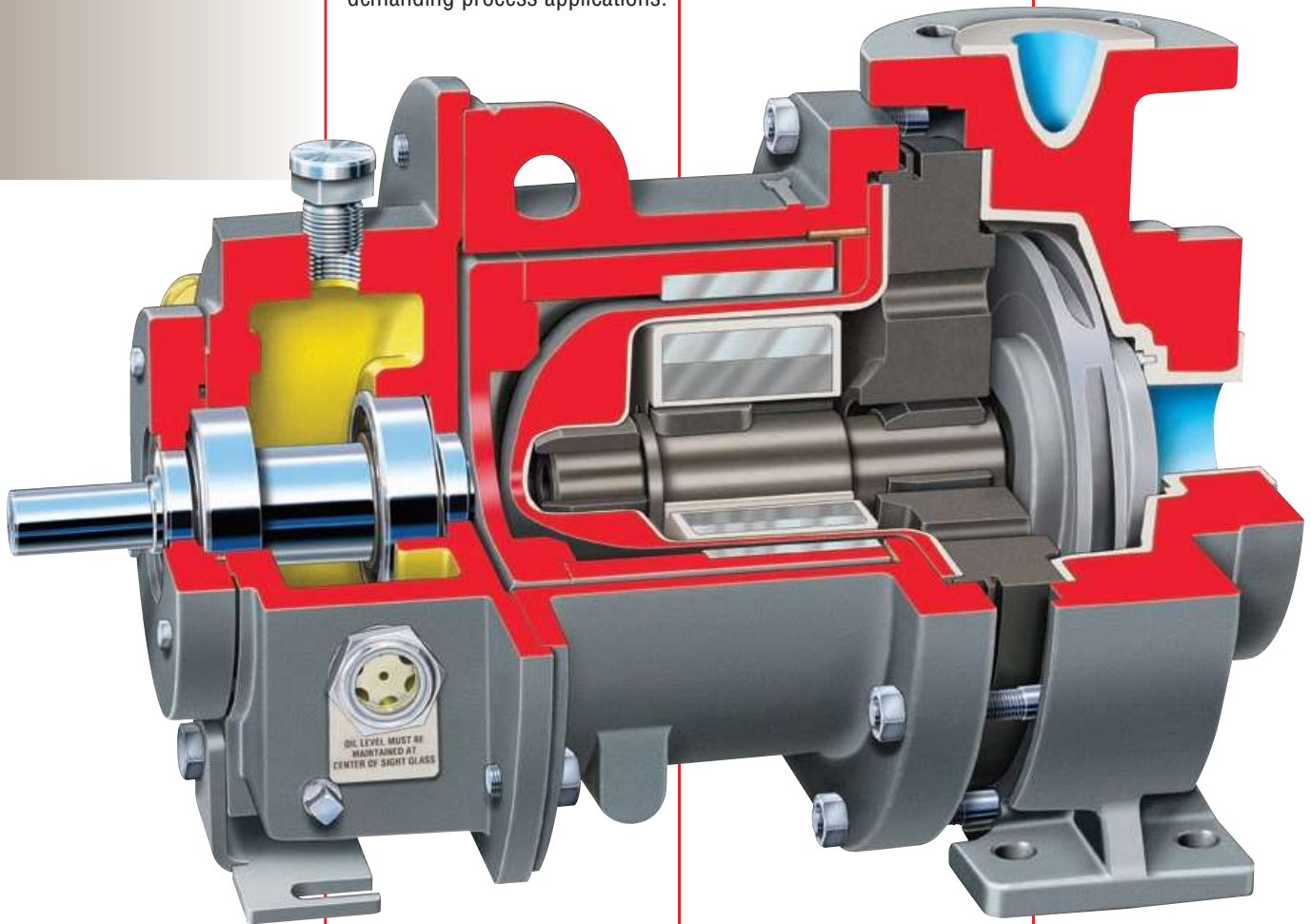

**Long Coupled Configuration** offers traditional bearing housing with flexible coupling.

**Fluoropolymer Lined Fiberglass Containment Shell** offers superior corrosion resistance and strength.

**Fluoropolymer PFA Lined Wet End** is globally preferred for its superior corrosion resistance and temperature allowance. PFA is carbon reinforced where required for stiffness and strength.

**Rare Earth Magnets** in synchronous drive design eliminate slippage and permit high temperature application.

**Separate Inner Magnet and Impeller Components** result in low cost maintenance and ease of upgrade.

**Rugged Silicon Carbide Radial and Axial Thrust Bearings** offer outstanding wear resistance and chemical inertness.

**Power Frame Pull-Out** permits safe power end maintenance without breaking sealed containment.

**Jackbolts** offer added safety for plant personnel and facilitate maintenance.

**Back Pull-Out Design** allows for pump removal without disturbing the casing.

**Non-Sparking Rub Pads** prevent contact of critical components in the unlikely event of outer magnet support bearing failure.

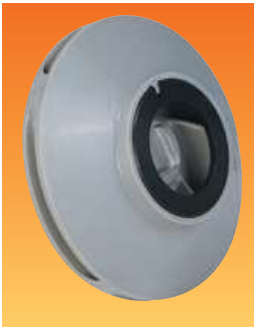

**Enclosed Lined Impeller** provides balanced hydraulic loads, extending bearing life.

**Rugged Design with the Customer in Mind**

PolyChem M-Series pumps were designed to offer the optimum in pump reliability and value, while maintaining a simple design for safety and ease of maintenance.

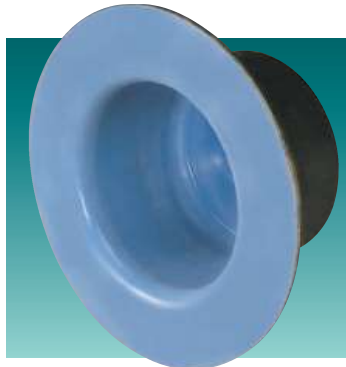

**PFA Lined Casing**

The Flowserve proprietary PFA molding processes ensure liner integrity.

- Ductile cast iron armor has a minimum PFA liner thickness of 3 mm (0.125 in)
- Armor meets ASTM A395 and GGG40.3 specifications



**PFA Lined Fiberglass Containment Shell**

is rated to 17 bar (250 psi) and offers excellent magnet efficiencies. Non-metallic construction eliminates magnetic losses and heat generation associated with metallic containment shells. The result is a more energy-efficient pump that uses a smaller motor and is less likely to cause vaporization of the pumping fluid.



**Large Silicon Carbide Rotating Shaft Offers**

ruggedness simply not found in other non-metallic pumps. PolyChem's rotating shaft is supported by silicon carbide bearings located securely in a reinforced fluoropolymer bearing holder, thereby eliminating the need for bearing support in the inlet of the pump.

**Standard Silicon Carbide Radial and Axial Thrust Bearings** are chemically inert and have exceptional wear resistance.

**Simplicity in Design**

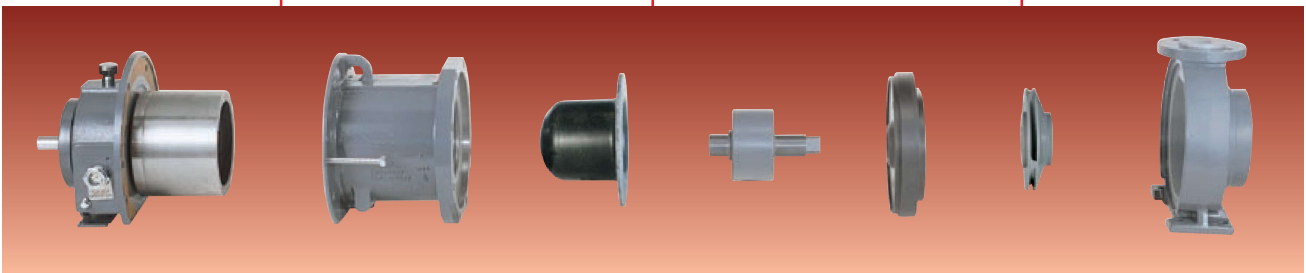

**PolyChem M-Series  
Fluoropolymer Lined  
Sealless Pumps**

**Technical  
Information**

M-Series pumps are designed for superior performance and reliability at reduced cost.

**Internal Circulation and Lubrication Path** is engineered for optimum performance.

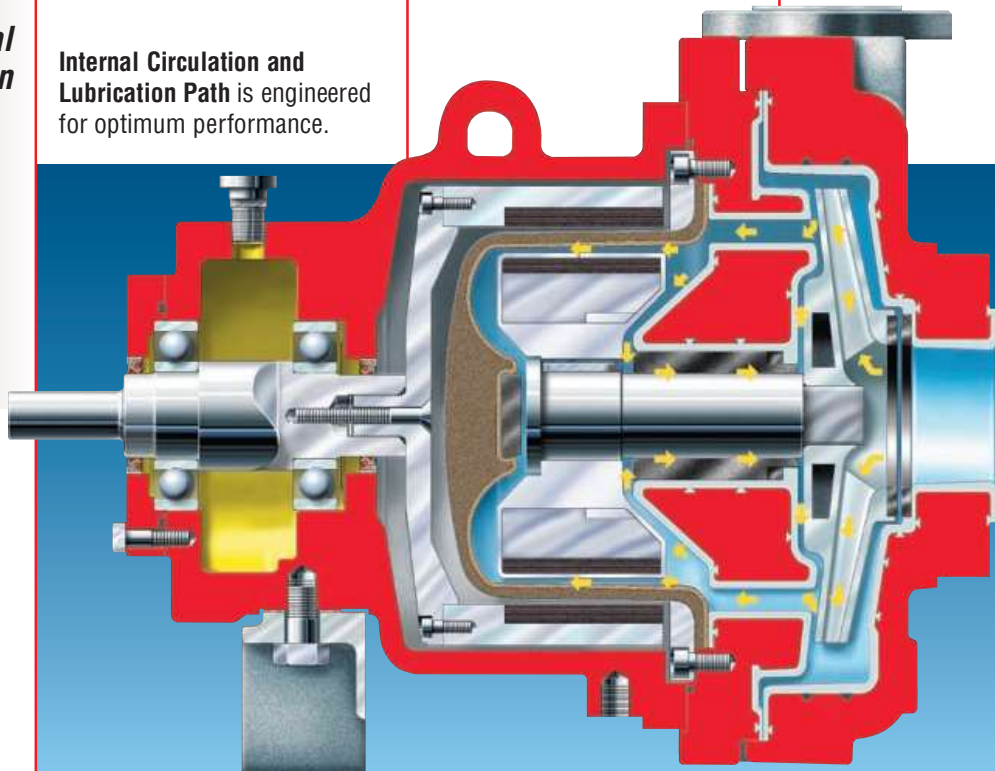

**Separate Inner Magnet and Impeller Components**

significantly reduce impeller replacement cost compared with integral assembly designs.

**Rotating Shaft Design** eliminates shaft support obstructions in the casing inlet which are common with stationary shaft designs.

- Improved performance
- Reduced NPSHr



**PolyChem  
M-Series  
Performance  
Curves**

PolyChem M-Series sealless pumps cover a broad hydraulic range.

**Thirteen Sizes**

- Four (4) Group 1 (ASME)
- Three (3) Group 2 (ASME)
- Three (3) Group A (ISO)
- Three (3) Group B/C (ISO)

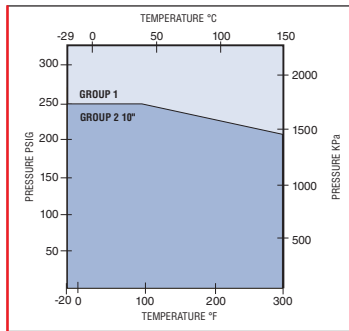

**Operating Parameters**

- Flows to 135 m<sup>3</sup>/h (600 gpm)
- Heads to 145 m (480 ft)
- Pressures to 17 bar (250 psi)
- Temperatures from -30°C (-20°F) to 150°C (300°F)

**M-Series ASME Range Chart**

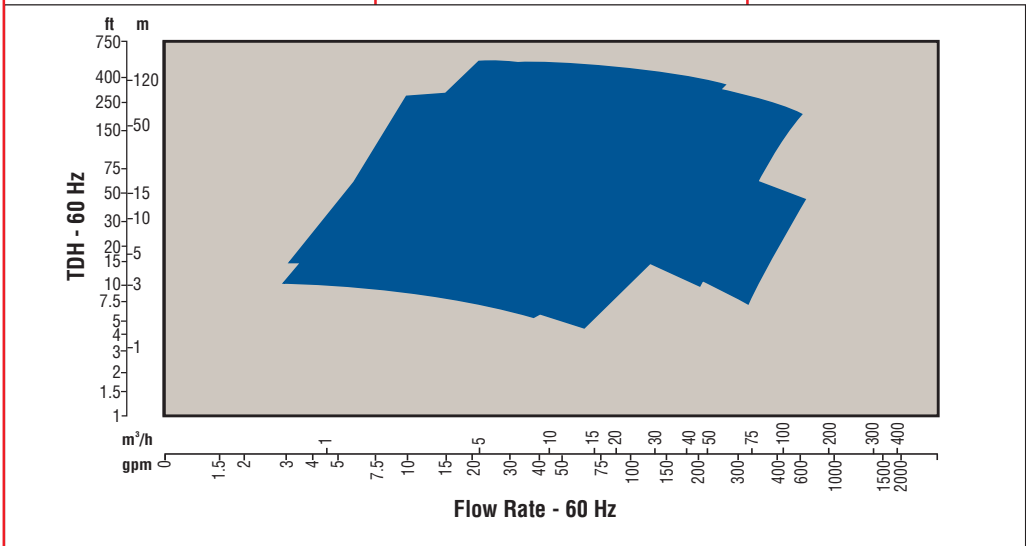

**M-Series ISO Range Chart**

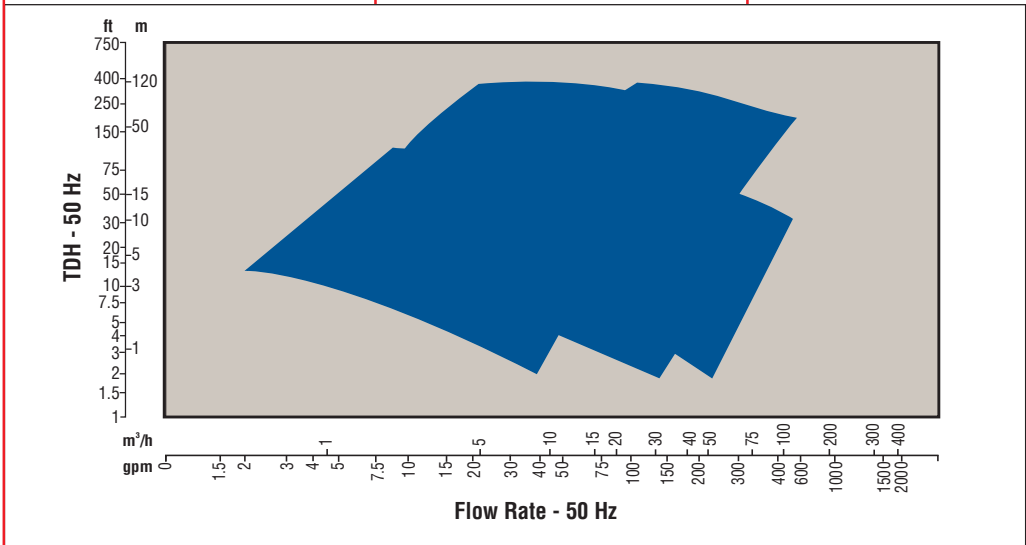

**PolyChem S-Series  
Fluoropolymer Lined  
Mechanically Sealed  
Pumps**

**Revolutionary Non-Metallic  
Pump Technology**

Flowserve fluoropolymer lined sealed pumps offer outstanding performance and significant economy in highly corrosive applications. Incorporating the proven Mark 3 power end, PolyChem S-Series pumps are engineered to maximize performance and reliability.

Addressing customer needs around the globe, PolyChem S-Series pumps meet the following dimensional standards:

- ASME B73.1
- ISO 2858/5199
- JIS drilling

**Operating Parameters**

- Flows to 420 m<sup>3</sup>/h (1850 gpm)
- Heads to 145 m (480 ft)
- Pressures to 17 bar (250 psi)
- Temperatures from -30°C (-20°F) to 150°C (300°F)

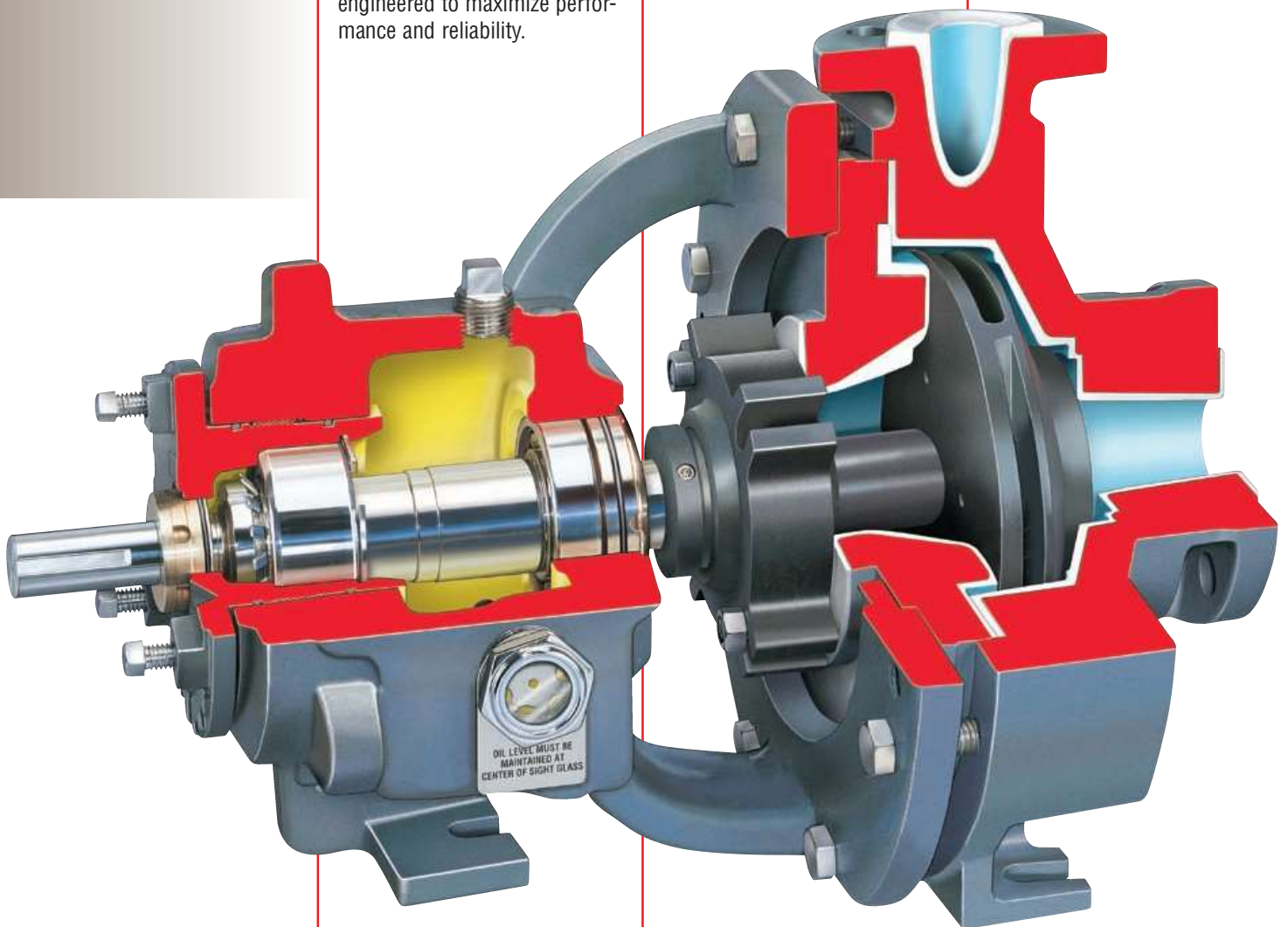

**External Micrometer Impeller Adjustment** accurately sets impeller in 20 seconds. Furthermore, mechanical seals and all critical settings can be set accurately in the shop.

**Fluoropolymer PFA Lined Wet End** is globally preferred for its superior corrosion resistance and temperature allowance.

**Enclosed Impeller**, through 250 mm (10 in), provides balanced hydraulic loads, extending bearing life. Open impeller available.

**Clean Room Assembly** of optional ANSI 3A™ power end (shown here) ensures optimum lubrication environment. Mark 3 power end is standard.

**Silicon Carbide Shaft Sleeve** mitigates corrosion and wear.

**Seal Chamber** with large tapered bore accommodates multiple seal selections. (See page 12 for typical seal arrangements.)

**Advanced FM SealSentry™ Design Technology**

Only Flowserve offers a non-metallic pump with the advantages of an oversized seal chamber with flow modifiers.

- Self-flushing
- Self-venting
- Self-draining

Seal life is extended due to superior purging of heat, solids and vapors. Costs are reduced because single seals often can be selected where dual seals or external flush and throat bushing combinations had been necessary.



Available open impeller

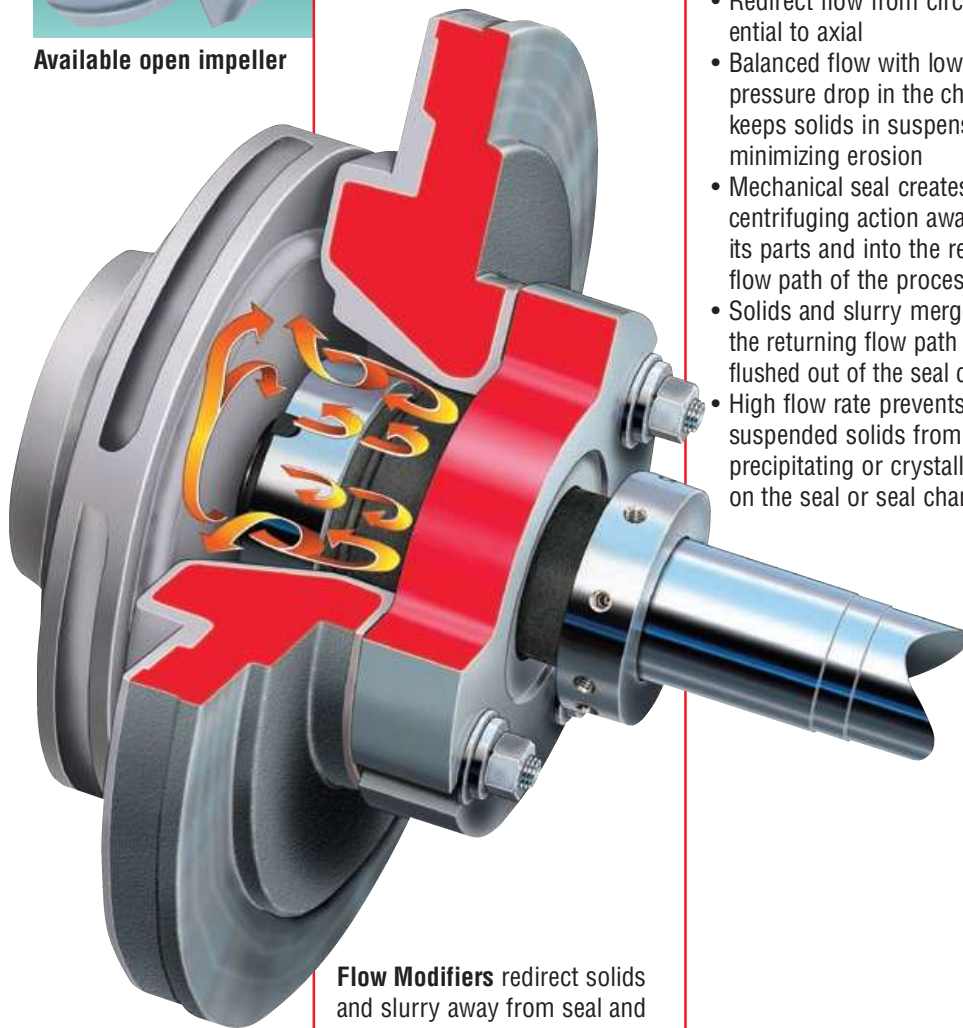

**Flow Modifiers** redirect solids and slurry away from seal and back into the flow path of the process liquid.

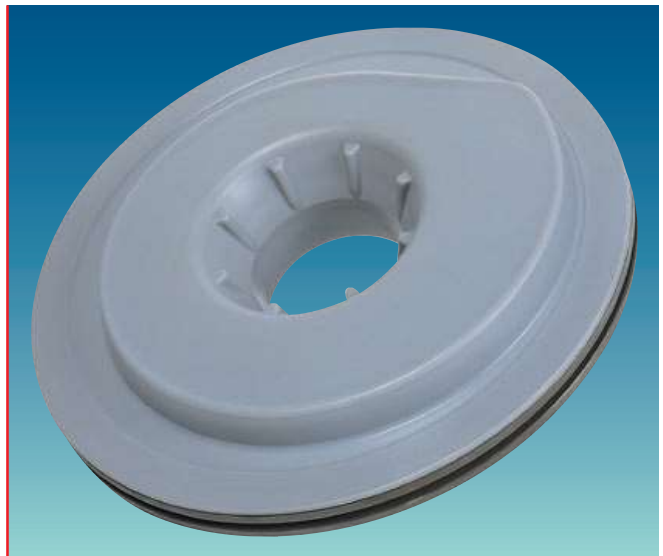

**Flow Modifiers Extend Mechanical Seal Life**

- Redirect flow from circumferential to axial
- Balanced flow with low pressure drop in the chamber keeps solids in suspension, minimizing erosion
- Mechanical seal creates a centrifuging action away from its parts and into the returning flow path of the process liquid
- Solids and slurry merge into the returning flow path and are flushed out of the seal chamber
- High flow rate prevents suspended solids from precipitating or crystallizing on the seal or seal chamber

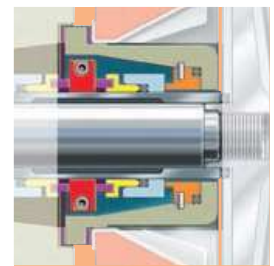

**Unique Seal Chamber Canister** allows double component seals to be applied in the FM seal chamber. This canister enables quick retrofits and eliminates the need to stock additional rear covers

**Choice of Power Ends**

- Standard Mark 3A power end
- Optional ANSI 3A™ power end (shown on page 10) with lifetime warranty, features Inpro/Seal's VBXX bearing isolators

**Power End Options**

- Alloy shaft sleeves
- Solid shafts
- Labyrinth seals
- Magnetic drain plug
- Oil slinger
- Regreasable or double shielded bearings
- Oil mist system

**PolyChem S-Series  
Fluoropolymer Lined  
Mechanically Sealed  
Pumps**

**Sealing Options**  
PolyChem S-Series pumps offer the advantage of innovative and readily available seal selections. Shown here are standard and recommended seal arrangements.

**Non-Metallic Single Cartridge**

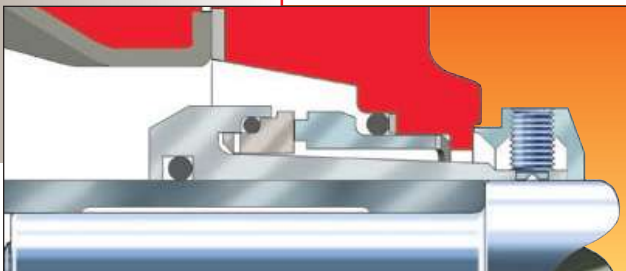

**Double Component (Collar Drive)**

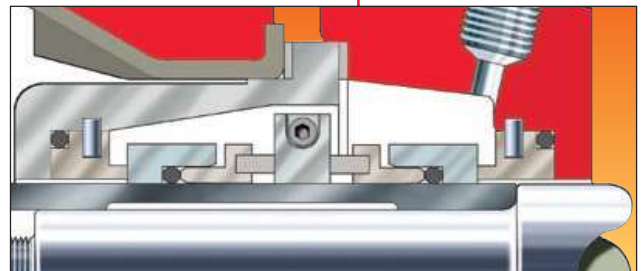

**Non-Metallic Single External**

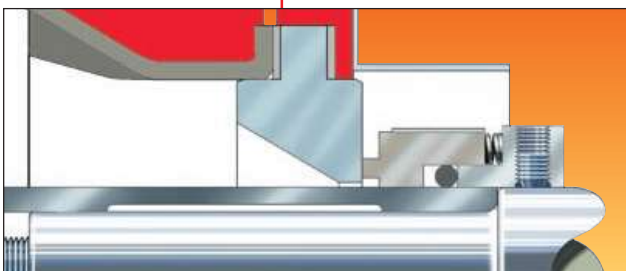

**Double Component (Friction Drive)**

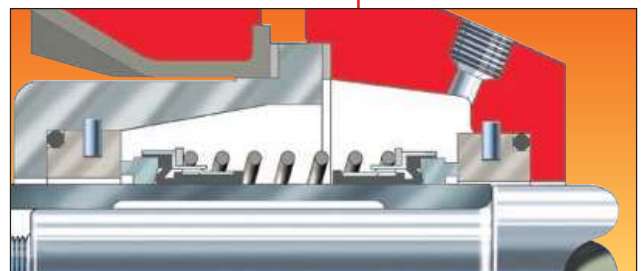

**Metallic Single Cartridge**

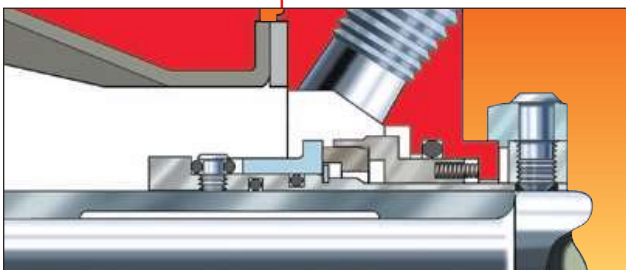

**Non-Metallic Double Cartridge**

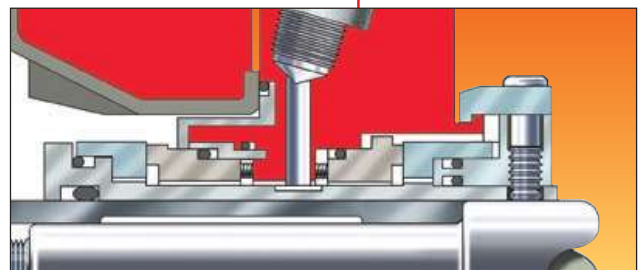

**Metallic Single Component**

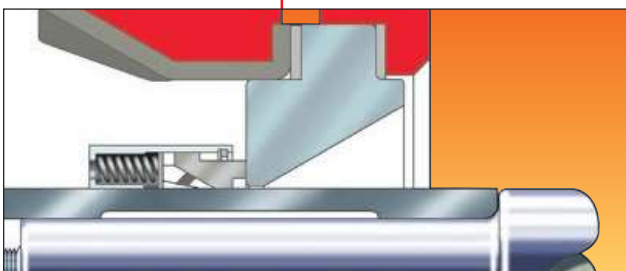

**Metallic Double Cartridge**

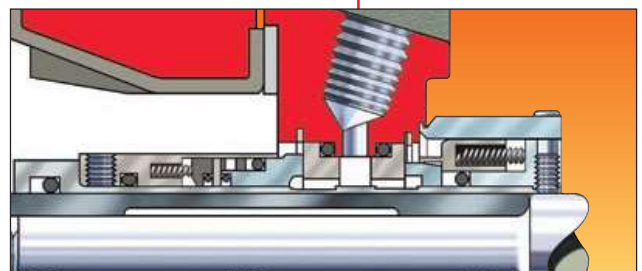

**PolyChem  
S-Series  
Performance  
Curves**

PolyChem S-Series sealed pumps cover a broad hydraulic range.

**Nineteen Sizes**

- Four (4) Group 1 (ASME)
- Six (6) Group 2 (ASME)
- Three (3) Group A (ISO)
- Six (6) Group B/C (ISO)

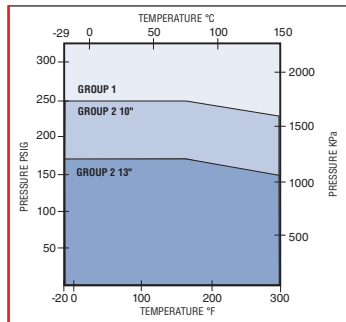

**Operating Parameters**

- Flows to 420 m<sup>3</sup>/h (1850 gpm)
- Heads to 145 m (480 ft)
- Pressures to 17 bar (250 psi)
- Temperatures from -30°C (-20°F) to 150°C (300°F)

**S-Series ANSI Range Chart**

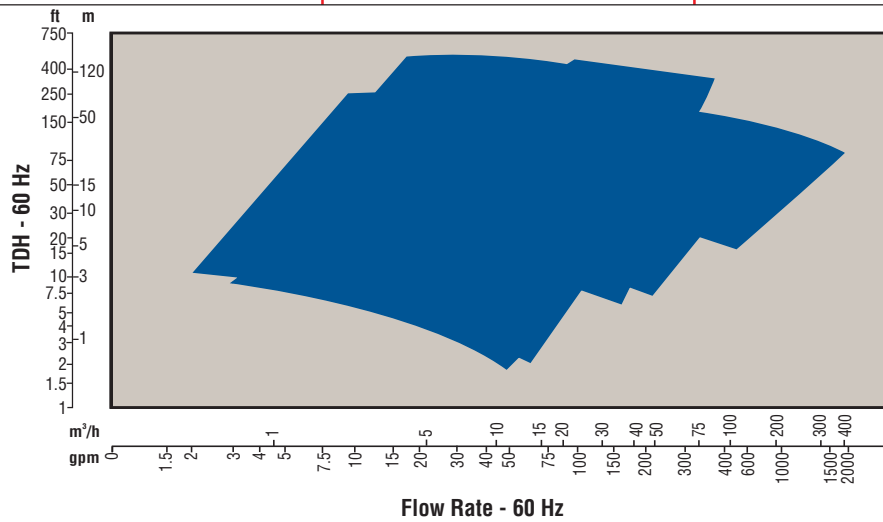

**S-Series ISO Range Chart**

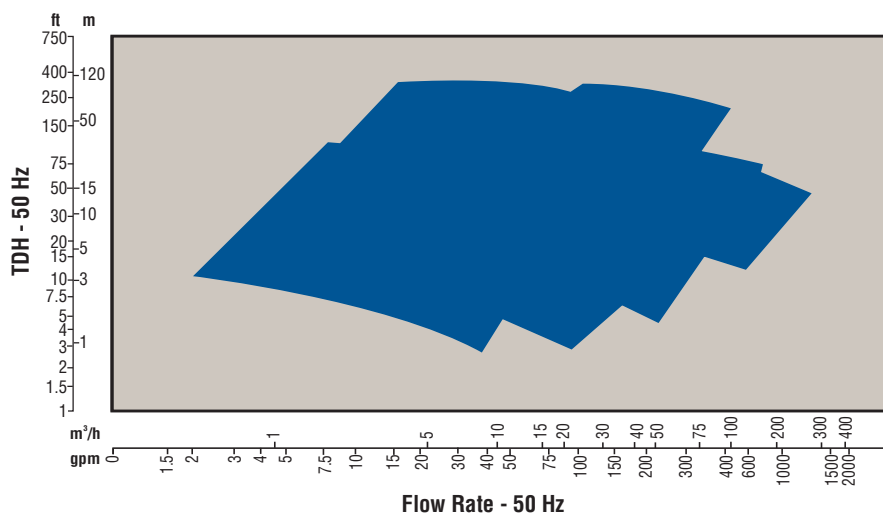

**PolyChem GRP Engineered Composite ANSI Pumps**

**The Low-Cost, Long-Term Solution to Corrosive Services**

The PolyChem GRP engineered composite pump is the result of intensive product development and installation experience. Made of premium Derakane® vinyl ester resin reinforced with randomly oriented glass fibers, the GRP pump is designed to

ASME B73.5M standards for chemical process pumps.

With corrosion resistance superior to many more expensive, highly alloyed metals and with costs closer to that of ductile iron, the PolyChem GRP has proven to be the low-cost, long-term solution in acidic and chloride-rich applications.

**Operating Parameters**

- Flows to 2050 m<sup>3</sup>/h (9000 gpm)
- Heads to 150 m (500 ft)
- Pressures to 17 bar (250 psi)
- Temperatures from -45°C (-50°F) to 120°C (250°F)

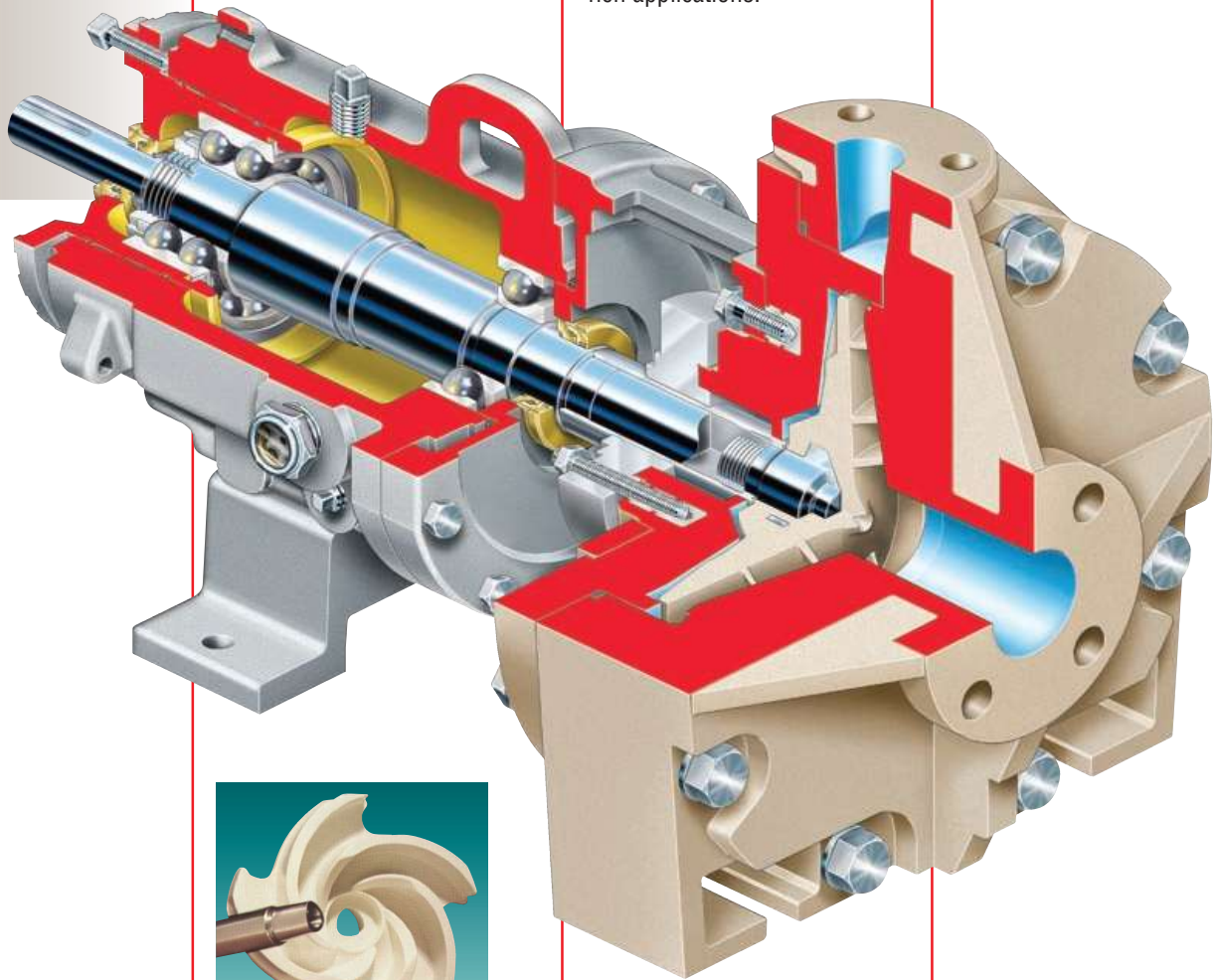

**Engineered Composite Material Construction** offers cost-effective corrosion resistance and is lightweight, non-galling, non-sparking, and non-conductive.

**Tapered Polygon Impeller Drive** provides exceptional torque carrying ability and unequalled shear strength for durability.

**Externally Adjustable, Semi-Open Impeller** is inherently balanced and provides consistently high efficiencies.

**Centerline Discharge Casing** with integrally molded flanges is fully gusseted for optimal nozzle loading capabilities.

**Standard Mark 3 Power End** with double lip oil seals and top vent breather.

**Low-Cost, Non-Metallic Replaceable Sleeve** mitigates shaft corrosion.

**Radial Fit and Square O-Rings** for the casing and impeller, respectively, protect the shaft from corrosive liquids.

**Flexible Spacer-Type Couplings** permit disassembly without disturbing the piping, driver or alignment.

© Derakane is a registered trademark of Dow Chemical Company



**Compression Molded**

GRP wet end components are compression molded at high temperatures and pressures to evenly distribute reinforcing fibers. This results in:

- Smooth hydraulic passages
- High efficiencies
- Lower operating costs
- High structural strength

**Stuffing Box Options**

Four stuffing boxes are available to maximize seal or packing life.

- Standard box with clamped seat gland accepts all types of single outside seals
- Standard box with with long gland accepts all types of inside seals, including single and double seals
- Packing box extension
- Taper bore box

**Self-Priming Option**

Made of a proprietary glass fiber reinforced thermosetting epoxy resin, the self-priming pump is built to ASME B73.1 dimensions. It is an excellent choice for corrosive applications such as:

- Industrial sumps
- Waste treatment pond transfer
- Tank car unloading
- Lift stations

**Operating Parameters**

- Flows to 115 m<sup>3</sup>/h (500 gpm)
- Heads to 115 m (375 ft)

**Typical GRP Seal Arrangements**

Seal Types	Unbalanced	Balanced
Single outside with clamped seats	Multiple spring, O-ring mounted	—
	Bellows, O-ring mounted	—
Double	Friction drive	—
	Multiple spring, O-ring mounted	—
	Multiple spring, PTFE mounted	—
Single inside with flexible seats	Single spring, elastomer bellows	
	Single spring, O-ring mounted	
	Multiple spring, PTFE mounted	
		Metal bellows, O-ring mounted
Single inside, cartridge	Multiple spring, O-ring mounted	
		Metal bellows, O-ring mounted
Double/tandem, cartridge	Multiple spring, O-ring mounted	
		Metal bellows, O-ring mounted



**ANSI 3A Power End** is so advanced it carries a lifetime warranty.

- Certified clean room assembly
- Inpro/Seal's VBXX non-contact Vapor Block Bearing Isolator keeps lubricants in and contaminants out
- Magnetic drain plug
- Top vent replaced with plug
- Lubrication options

**PolyChem VGRP  
Engineered  
Composite  
ANSI Pumps**

The PolyChem VGRP is a fiberglass, vertical immersion, open impeller pump designed for corrosive wet pit applications in waste handling and chemical transfer.

**VGRP Operating Parameters**

- Flows to 565 m<sup>3</sup>/h (2500 gpm)
- Heads to 110 m (350 ft)
- Pressures to 17 bar (250 psi)
- Temperatures from -30°C (-20°F) to 90°C (200°F)
- Pit depths to 4.25 m (14 ft); 6.75 m (22 ft) with optional tailpipe

*Unique Single-Piece Fiberglass Column is generously sized for strength and rigidity. Available in 0.6 m (2 ft) to 4.3 m (14 ft) lengths.*

*Shaft and Bearing System operates well below the first critical speed, resulting in less shaft whip and longer bearing life. Meets API bearing span requirements.*

*Bearings can be lubricated by external flush, or self-lubricated by the pump fluid.*

*Patented Pull-Out Bearing Retainer streamlines maintenance.*

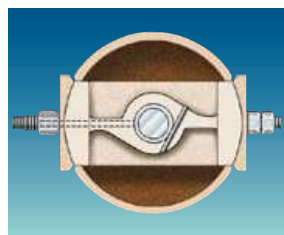

**Pullout Bearing Retainer**

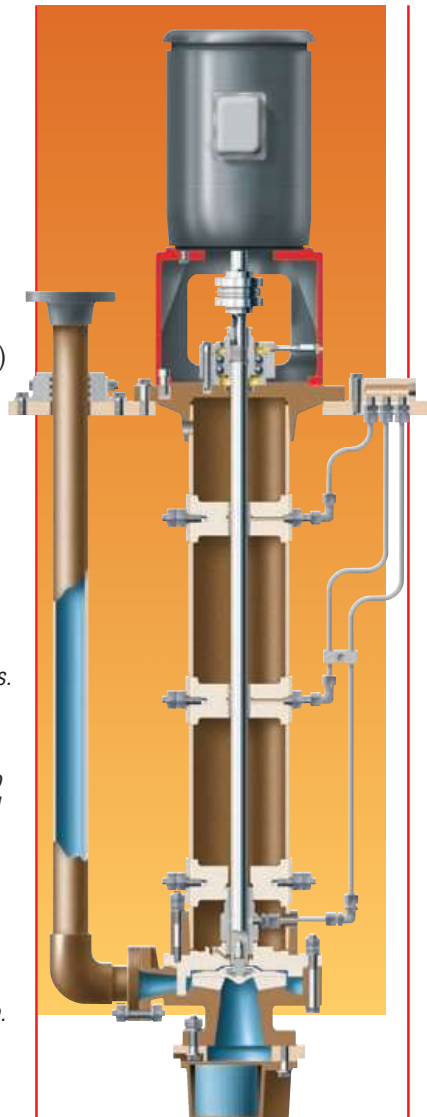

**Features**

- C-Face NEMA motors
- API bearing spacing
- Integral double row thrust bearings
- Fiberglass mounting plate
- Single connection for bearing lubrication
- Vapor-sealed thrust bearing

**Options**

- Simplex and duplex pit covers
- Float switches
- 316 SS, Alloy 20, Hastelloy® or titanium alloy shafts
- Particulate separators for dirty product lubrication
- Non-metallic lubrication lines
- Tailpipe

© Hastelloy is a registered trademark of Haynes International, Inc.



## PolyChem GRP and VGRP Performance Curves

### GRP Sixteen Sizes

- Four (4) Group 1
- Nine (9) Group 2
- Two (2) Group 3
- One (1) Group 4

GRP

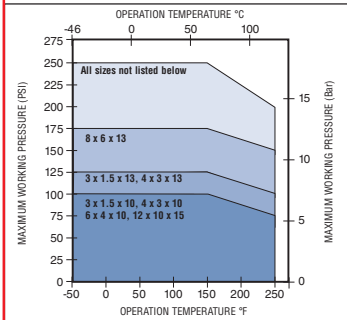

### VGRP Fourteen Sizes

- Four (4) Group 1
- Nine (9) Group 2
- One (1) Group 3

VGRP

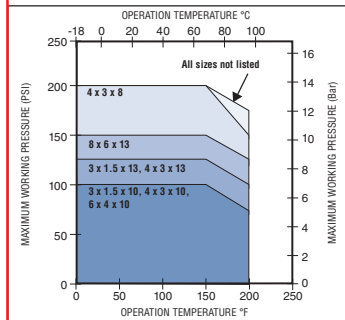

### GRP Operating Parameters

- Flows to 2050 m<sup>3</sup>/h (9000 gpm)
- Heads to 150 m (500 ft)
- Pressures to 17 bar (250 psi)
- Temperatures from -45°C (-50°F) to 120°C (250°F)

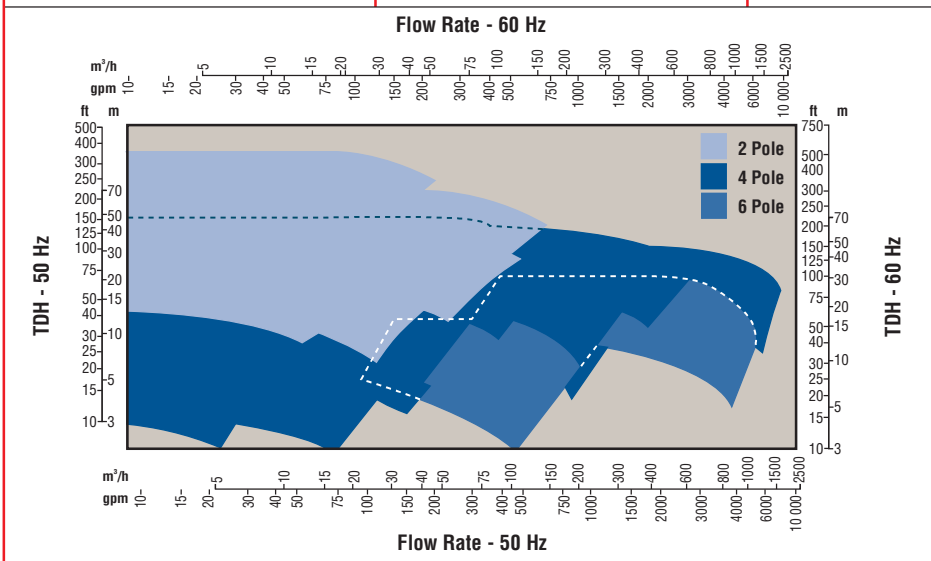

### VGRP Range Chart

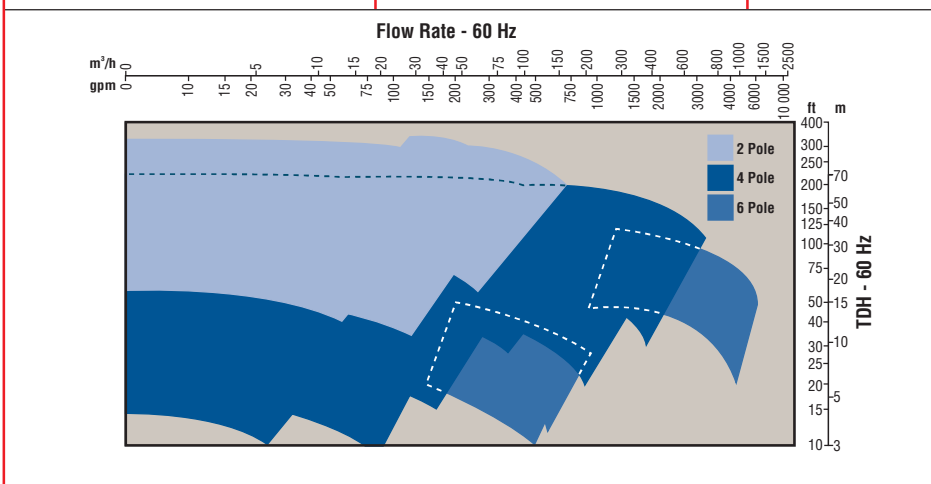

## Pre-Engineered Baseplate Designs

### Extend Pump Life and Reduce Maintenance Costs

The Flowserve family of pre-engineered baseplates further extends pump life by reducing internal stress and vibrations. That is why Flowserve recommends reinforced rigid baseplates.

Flowserve offers a broad range of metallic and non-metallic, grout and stilt mounted designs with standard options. This provides flexibility in choosing the baseplate that best meets application needs and operating budget.

**Standard steel baseplate**



**PolyBase™ baseplate**



**Reinforced baseplate – stilt mounted**



**Reinforced baseplate – foundation mounted**



**Heavy-duty, foundation mounted**

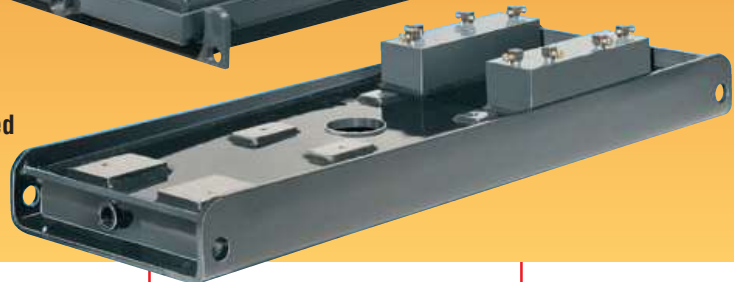

### Baseplate Materials

- Steel
- Rolled steel
- Stainless steel
- Polymer concrete

### Baseplate Options

- Stilt mounting
- Spring mounting
- Drain rims, pans, and connections
- Polycrrete mounts
- Motor feet adjusters
- Earthing points

### Polybase – Polymer Concrete Baseplate

- Low installed cost
- Superior vibration dampening
- Corrosion resistant
- Superior resistance to twisting or diaphragming
- Optional catch basin and grout holes
- Inserts to mount alternate equipment configuration requirements

***Polyshield  
Polymer  
Baseplate and  
Foundation  
System***

The **Polyshield Baseplate and Foundation System** is the superior solution for cost effective, high performance pump installation. In one complete unit it combines a traditional baseplate with a formed concrete foundation for pump-drive sets.

**Benefits of Selecting the Polyshield Baseplate and Foundation System**

- Time savings
  - Quick installation time
  - Reduces time span from receipt at jobsite to commissioning
- Cost savings
  - Reduces total installed cost
  - Dramatically minimizes field rework necessary to meet specifications
- Better performance and reliability
  - Extended pump life
  - Reduced vibration
  - Improved corrosion resistance
- Single structure convenience
  - One-piece construction
  - Flat mounting surfaces
  - One-piece motor mounting block

The Polyshield baseplate and foundation system can be combined with numerous pump designs, including:

- ISO and ASME metallic and non-metallic
- Foot- and frame-mounted general industrial
- Foot-mounted between bearing
- ISO 13709/API 610

*Please see Bulletin PS-90-2 for more complete product information*

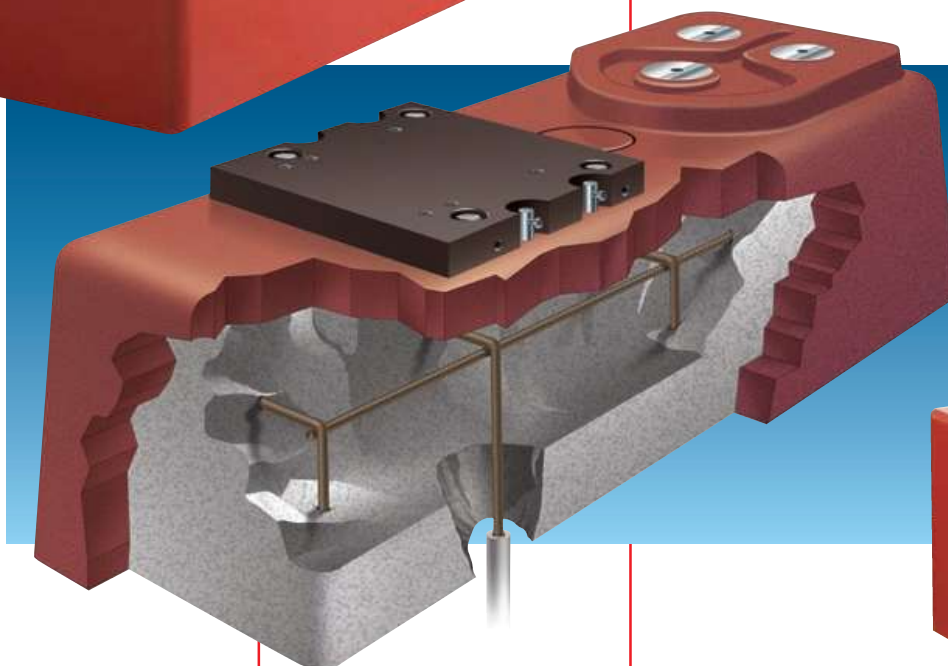

## Pump Accessories

**ClearGuard and DurcoShield Non-Metallic Safety Guards**  
ClearGuard and DurcoShield pump guards permit visual inspection of coupling and seal areas, respectively, while protecting personnel from potential safety hazards of rotating parts. Constructed of durable and transparent polycarbonate with UV light inhibitors, they are designed to withstand tough chemical processing environments.

**DurcoShield** splash and shaft guard is a one-piece shield that envelops the open areas between the bearing housing and casing. Suitable for applications to 150°C (300°F), DurcoShield protects from:

- Process fluid spray
- Rotating shaft and seal components

**ClearGuard** meets machinery guard safety guidelines. Nothing larger than 6 mm (0.24 in) in diameter can enter the shell. Furthermore, the ability to inspect the coupling through ClearGuard can provide early warning of deteriorating or malfunctioning components.

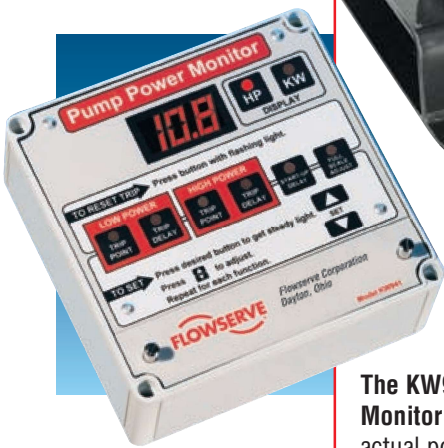

**The KW941 Pump Power Monitor** monitors and displays actual power to the pump, offering simultaneous protection from underload and overload operating conditions.

The KW941 helps to eliminate costly downtime and expensive pump repairs caused by:

- Dry running
- Pump overloads
- Cavitation
- Blocked lines
- Closed suction or discharge valves
- Excessive wear or rubbing



**PROS+**  
PROS+ proposal and order system is the most comprehensive and user friendly pump selection program in the industry. This software ensures correct sizing and selection of Flowserve pumps to best suit your process application needs.

*Pros+ is available from your local sales representative or on-line at [www.flowserve.com](http://www.flowserve.com).*

**CPXS and Guardian Magnetic Drive Pumps**  
**CPX ISO Chemical Process Pumps**

**CPXS and Guardian® Magnetically Driven Pumps**

Flowserve offers highly reliable magnetically driven pumps to both ASME and ISO specifications. The CPXS (ISO) and Guardian (ASME) pumps are ideal for emission free service requirements.

**Operating Parameters**

- Flows to 375 m<sup>3</sup>/h (1650 gpm)
- Heads to 215 m (700 ft)
- High temperatures design to 290°C (550°F)
- Pressures to 25 bar (365 psi)

*Please see Bulletin PS-10-14 for more information on the Guardian and Bulletin PS-10-30 for more information on the CPXS.*

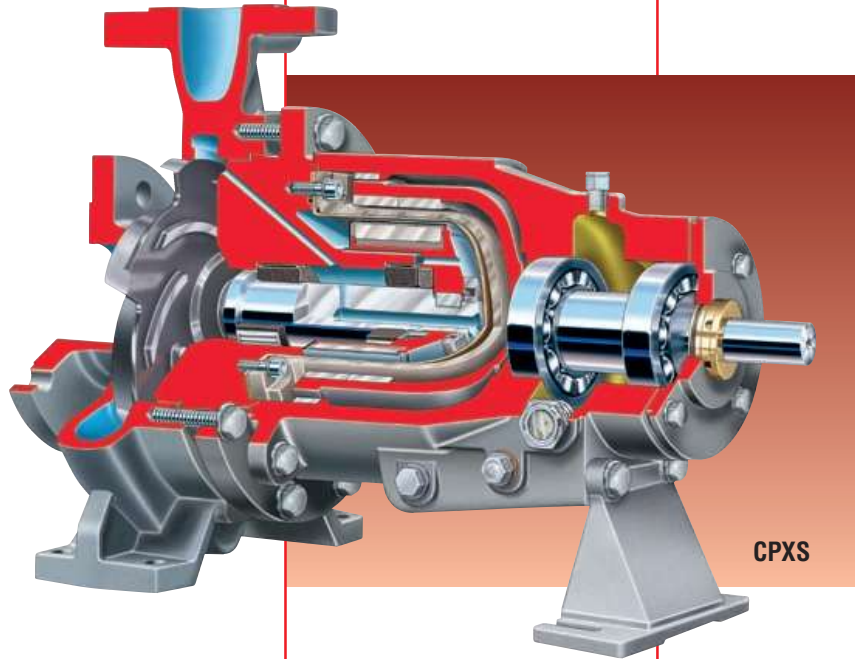

**CPX ISO Standard Chemical Process Pump**

Offering state-of-the-art hydraulics, the CPX pump is designed for chemical process applications in which high performance, high efficiency and low NPSH are required.

Conforming to ISO 2858 dimensional and ISO 5199 design criteria, the CPX is CE marked and compliant with applicable European directives, such as ATEX.

**Operating Parameters**

- Flows to 1400 m<sup>3</sup>/h (6160 gpm)
- Heads to 220 m (720 ft)
- Temperatures from -80°C (-110°F) to 350°C (660°F)
- Pressures to 25 bar (365 psi)

*Please see Bulletin PS-10-30 for more complete product information.*

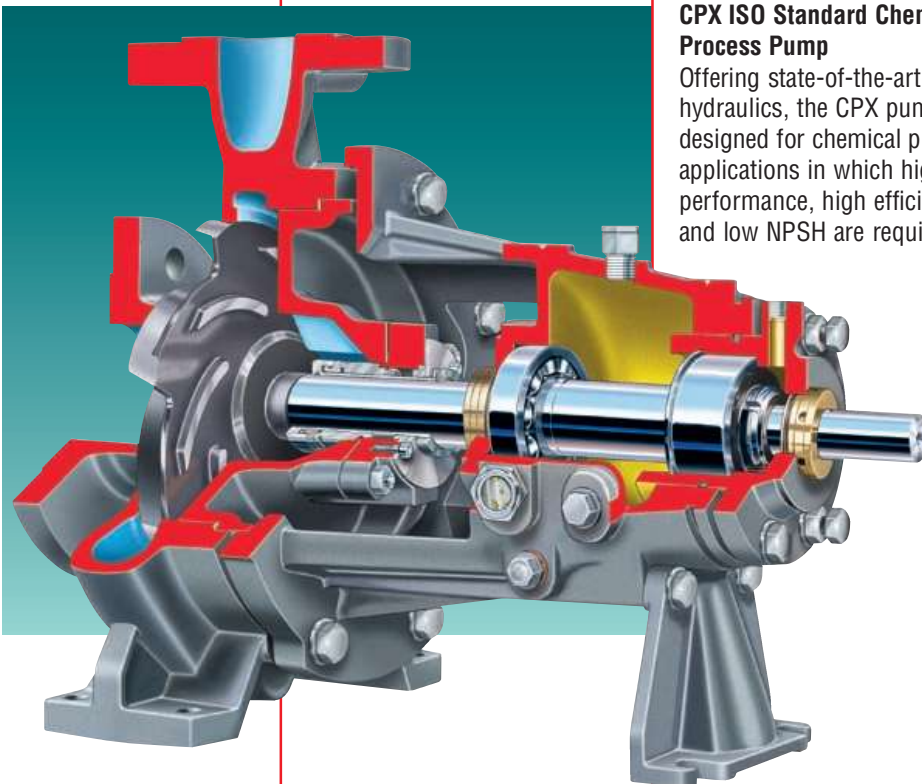

**Durco Mark 3 ASME  
Standard and  
In-Line Pumps**

**Durco Mark 3**

With its reverse vane impeller, SealSentry family of seal chambers, and the optional ANSI 3A power end, the Durco Mark 3 Standard pump is recognized worldwide as the premier name in ASME chemical process pumps.

**Thirty Sizes**

- Seven (7) Group 1
- Sixteen (16) Group 2
- Seven (7) Group 3

**Operating Parameters**

- Flows to 1680 m<sup>3</sup>/h (7400 gpm)
- Heads to 215 m (700 ft)
- Pressures to 27 bar (400 psi)
- Temperatures from -75°C (-100°F) to 370°C (700°F)

*Please see Bulletin PS-10-13 for more complete product information.*

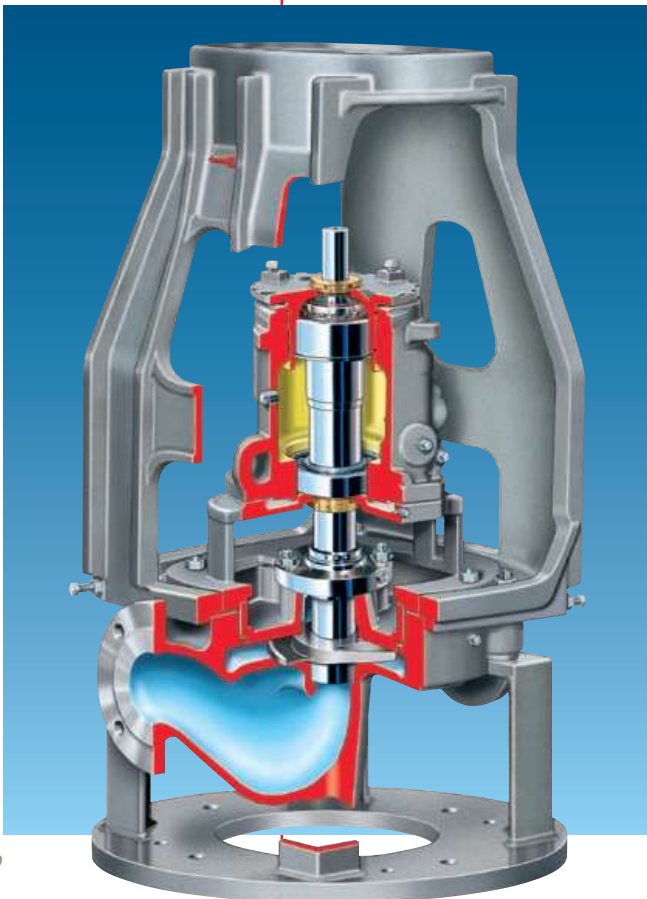
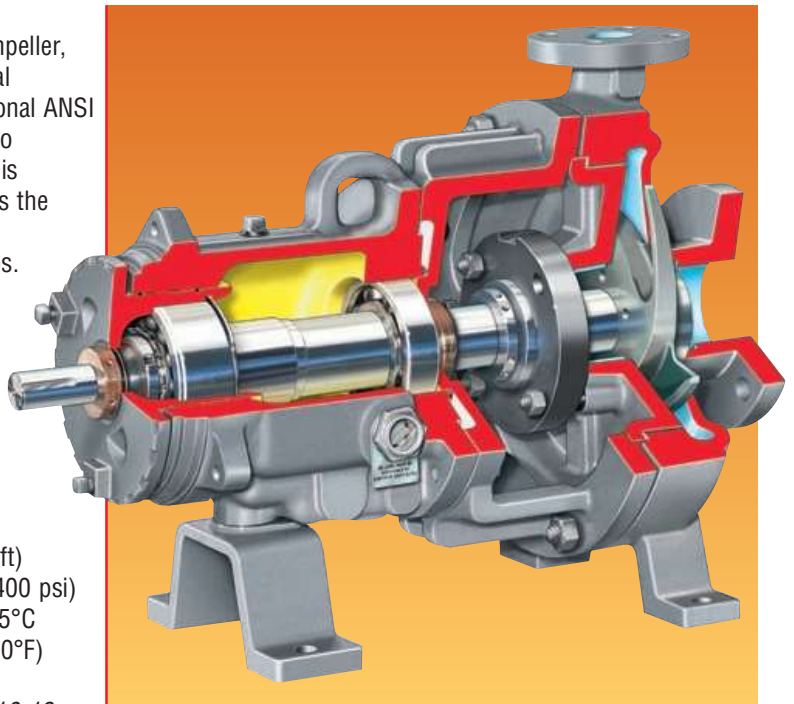

**Durco Mark 3 In-Line**

Designed to exceed ASME B73.2 criteria, the Mark 3 In-Line process pump offers improved reliability and extended pump life. The space-saving Mark 3 In-Line has broad application in chemical and hydrocarbon processing as well as in general industry. With its own independent bearing housing and rigid C-flange style motor adapter, the Mark 3 In-Line remains one of the most reliable process pump designs available.

**Operating Parameters**

- Flows to 370 m<sup>3</sup>/h (1630 gpm)
- Heads to 230 m (760 ft)
- Pressures to 24 bar (350 psi)
- Temperatures to 370°C (700°F)

*Please see Bulletin PS-10-15 for more complete product information.*

**Global Engineered Services and Support**

- Total Cost Reduction*
- Asset Management*
- Product Life Cycle*
- Performance Re-rates*
- Site Diagnostics*
- Repair Services*
- Energy Management*
- Spare Parts*
- Maintenance Contracts*
- Materials Upgrades*
- Turnkey Services*
- Field Repairs*
- Installation*
- Project Supervision*
- Commissioning*
- Equipment Upgrades*
- Condition Monitoring*
- Systems Analysis*
- Field Machining*

**Service Dedication**

Flowserve Engineered Services is focused on providing customers with uncompromising service and support, where and when needed. Dedicated to delivering the highest quality support, Engineered Services integrates its extensive pump and materials engineering knowledge with creative service solutions. Engineered Services fully understands the business challenges facing customers and is prepared to manage solutions to succeed as a team.

A worldwide network of service and repair centers staffed by highly skilled engineers and technicians is available around the clock, seven days a week to respond to customer queries, to evaluate and troubleshoot problems and to provide reliable solutions.



**Strength of Experience, Commitment to Excellence**

Flowserve has long served industries requiring superior equipment performance and service life.

- Oil and gas production
- Hydrocarbon processing
- Chemical processing
- Water resources
- Power generation
- Nuclear
- Mining and mineral processing
- Pulp and paper
- General industry

Engineered Services is dedicated to maximizing equipment performance and providing reliability-centered maintenance programs for pumps and related equipment, regardless of manufacturer. Using the FlowStar™ asset management software, Engineered Services tracks performance and supports improvement programs using a service life cycle cost business approach. The results are improved reliability and increased profitability.

**Business Partner**

Flowserve partners with customers to respond to the dynamic business conditions that affect them. Flowserve will work with customers to drive efficiency, maximize throughput and control process quality. Whether user needs involve on-site technical assistance or broader project planning with full turnkey responsibility, Flowserve Engineered Services will deliver professional, reliable results.

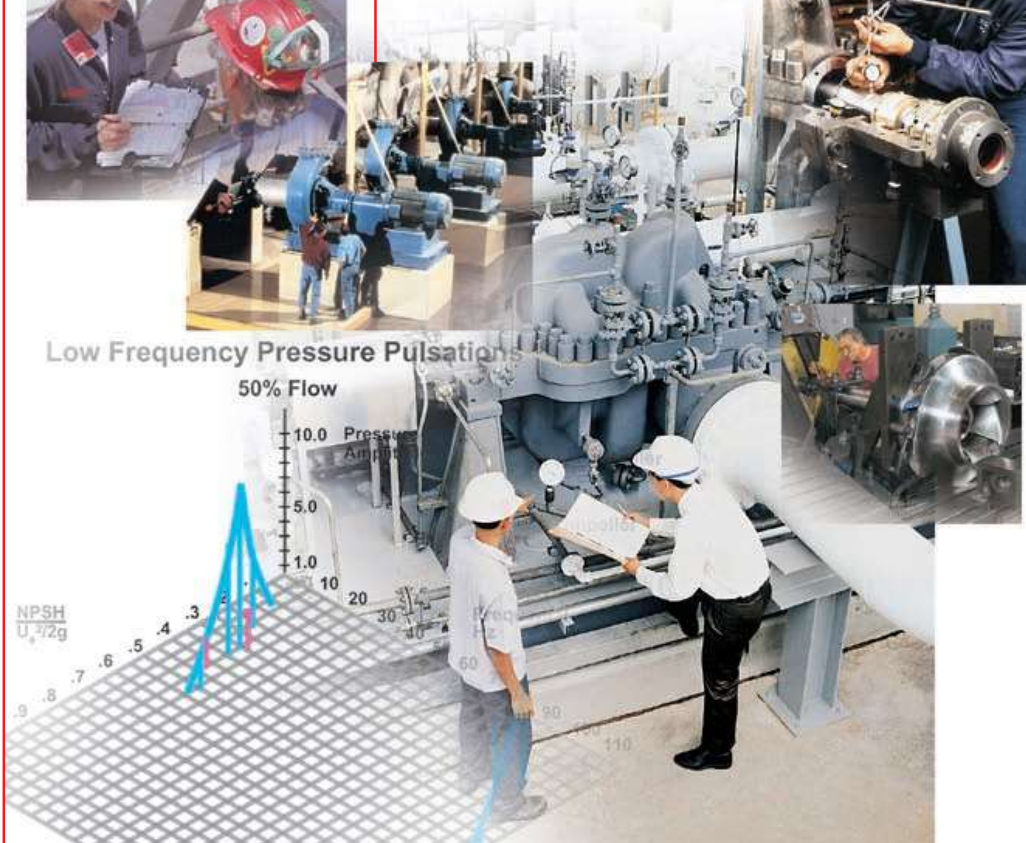

**Flowserve... Supporting Our Customers  
With The World's Leading  
Pump Brands**



**USA and Canada**

Flowserve Corporation  
5215 North O'Connor Blvd.  
Suite 2300  
Irving, Texas 75039-5421 USA  
Telephone: 1 937 890 5839

**Europe, Middle East, Africa**

Flowserve Corporation  
Gebouw Hagepoint  
Westbroek 39-51  
4822 ZX Breda  
Netherlands  
Telephone: 31 76 502 8920



*Your local Flowserve representative:*

**Компания ПромХимТех-  
официальный дистрибьютор  
насосов Flowserve  
[www.promhimtech.ru](http://www.promhimtech.ru)  
Тел. 8 800 250-01-54  
e-mail: [zakaz@promhimtech.ru](mailto:zakaz@promhimtech.ru)**

**Latin America**

Flowserve Corporation  
Martín Rodríguez 4460  
B1644CGN-Victoria-San Fernando  
Buenos Aires, Argentina  
Telephone: 54 11 4006 8700  
Telefax: 54 11 4714 1610

**Asia Pacific**

Flowserve Pte. Ltd.  
10 Tuas Loop  
Singapore 637345  
Telephone: 65 6771 0600  
Telefax: 65 6779 4607