

# Hydraulic Coverage

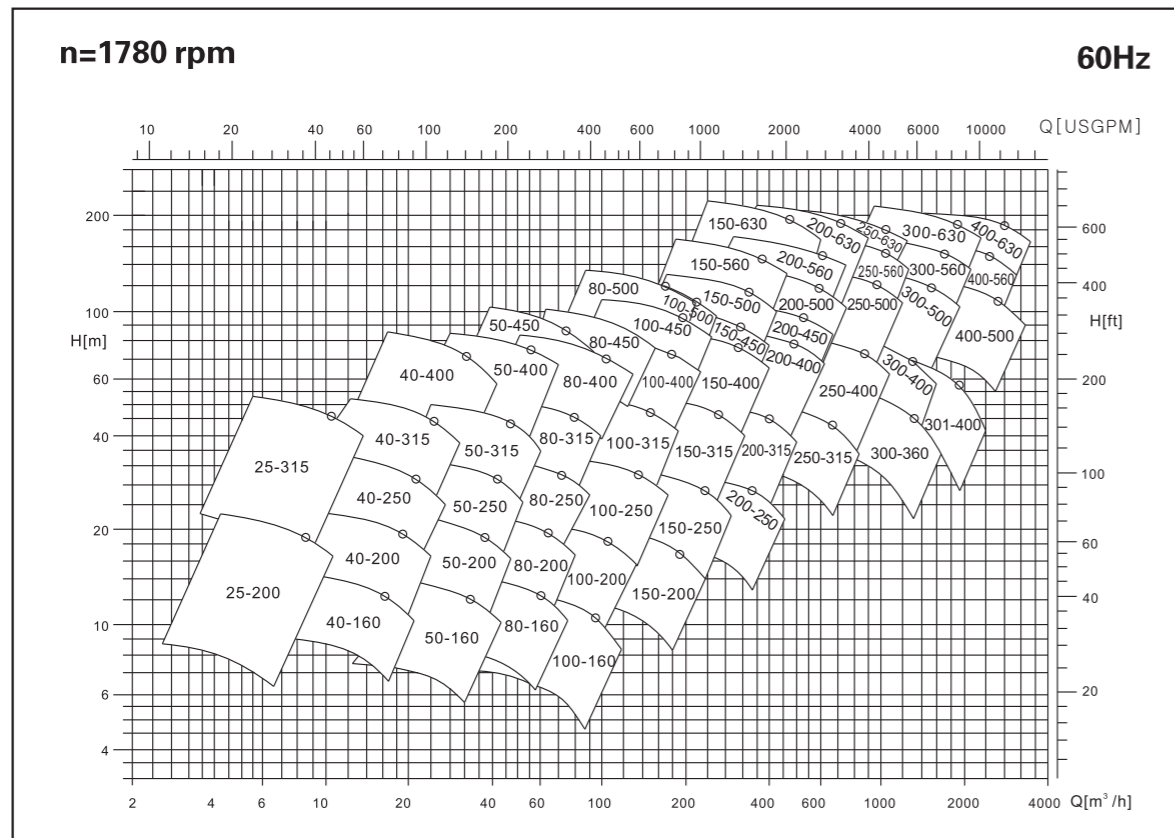

**CA, CE, CF**

**Heavy Duty Petrochemical Process Pumps**

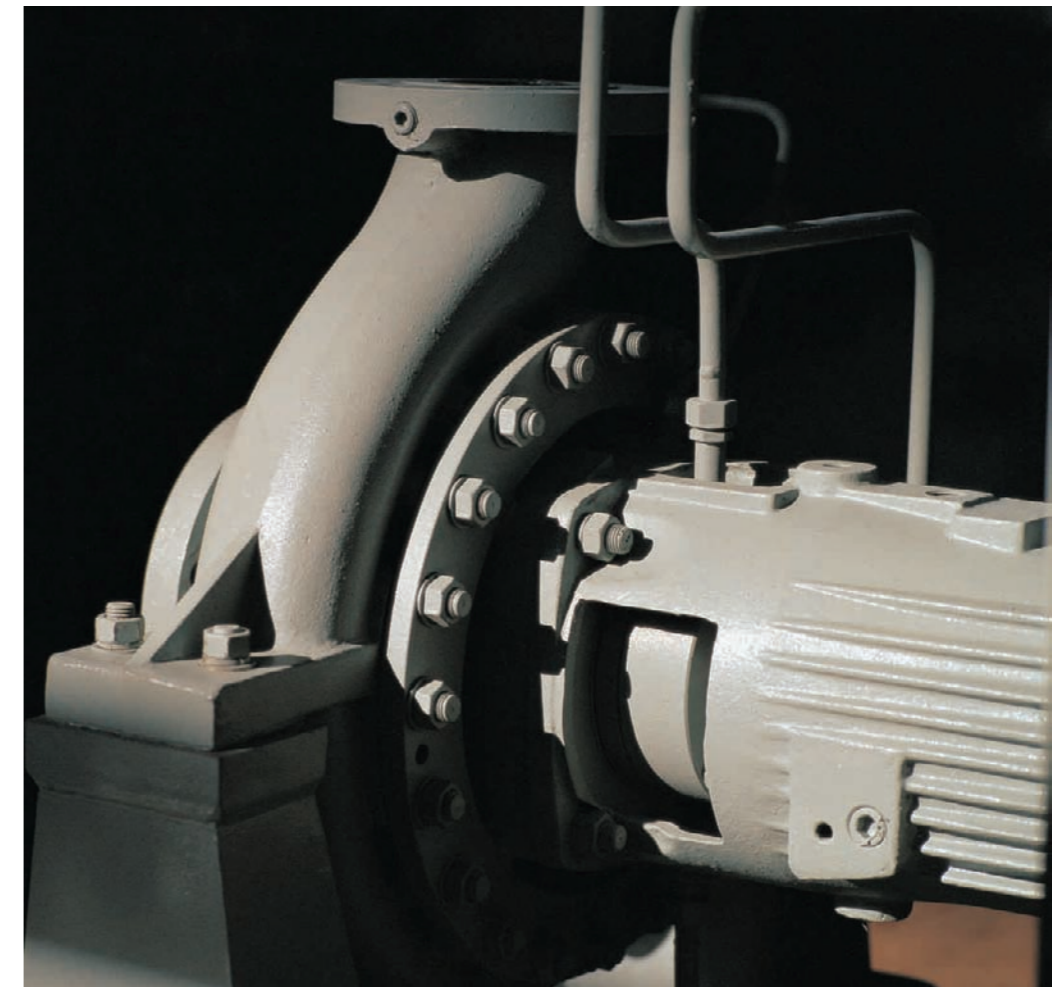
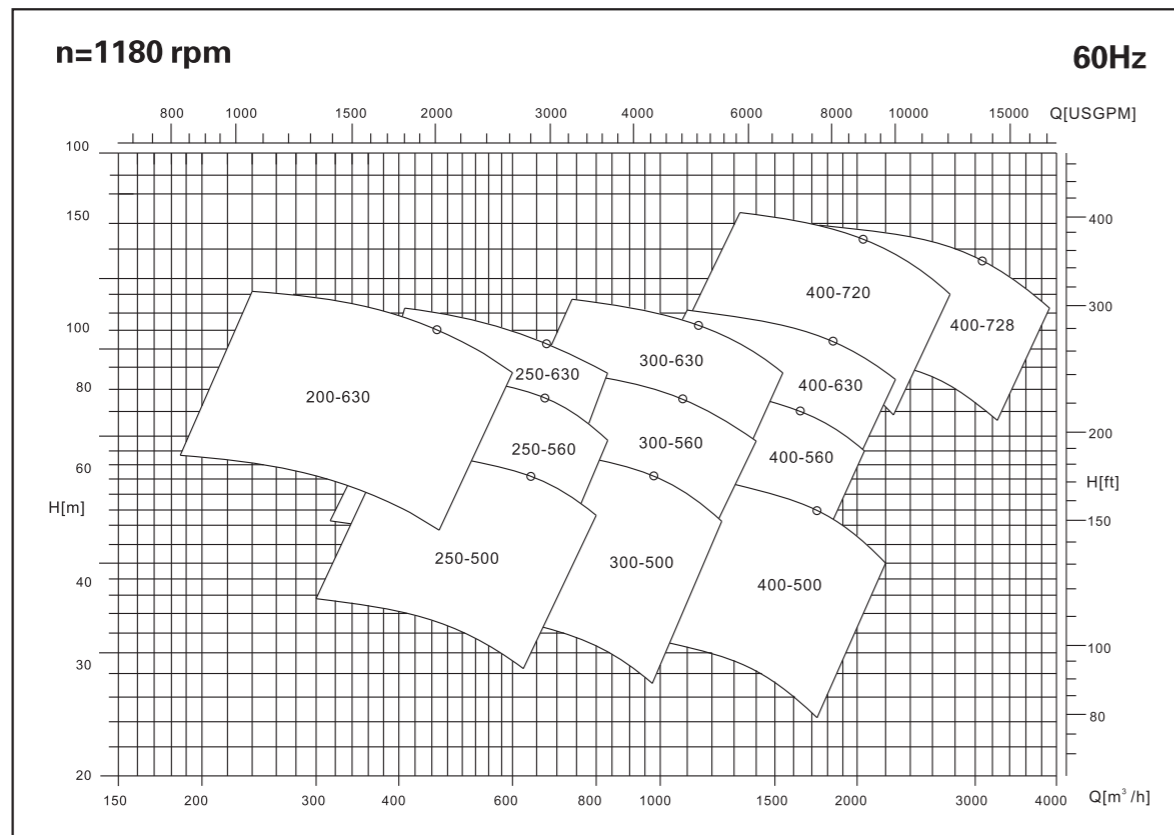

**NANFANG PUMP INDUSTRY CO., LTD.**

NF0009

## Application

Refineries	Petrochemical industry
Coal processing	Lower temperature engineer
Chemical industry	Fibre industry
Paper and pulp industry	Sugar industry
Sea water	Water industry
Air condition	Nuclear power station
Offshore industry	

## Performance Range

Size	25 up to 400mm
Capacity	up to 2600m <sup>3</sup> /h
Head	up to 250m
Working pressure	up to 7.5Mpa
Operating temperature	-80°C up to +450°C

## Standard Material

According to API 610 standard

## Description

Single stage, horizontal volute casing pump with feet below and single entry impeller, end suction type. Depending on operating conditions hydraulic balance provided by front or wear rings and balance holes.

Full compliance with the latest edition of API 610, heavy duty fan cooled bearing housing, heavy duty and non-grout baseplates for PAU and offshore application.

Casing cover with cooling or heating connections, shaft sealing by packing or mechanical seals of any design (single or double working), connections for cooling, flushing or sealing liquid.

Standard pipework according to API 682 Plans. Cooling system for high temperature pumping. Flanges according to DIN or ANSI.

CA working pressure up to 2.5Mpa, can be supplied with open impeller. (Code OH1)

CE working pressure up to 5.0Mpa, can be supplied with open impeller. (Code OH2)

CF working pressure up to 7.5Mpa. (Code OH2)

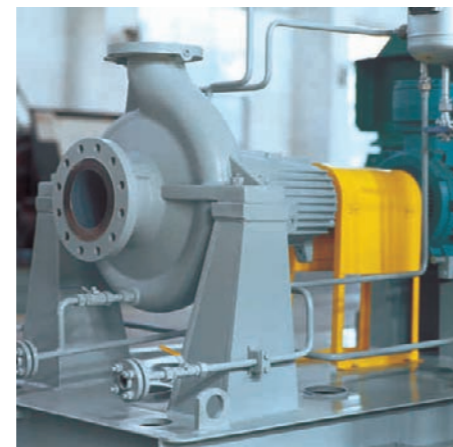

## Sectional Drawing

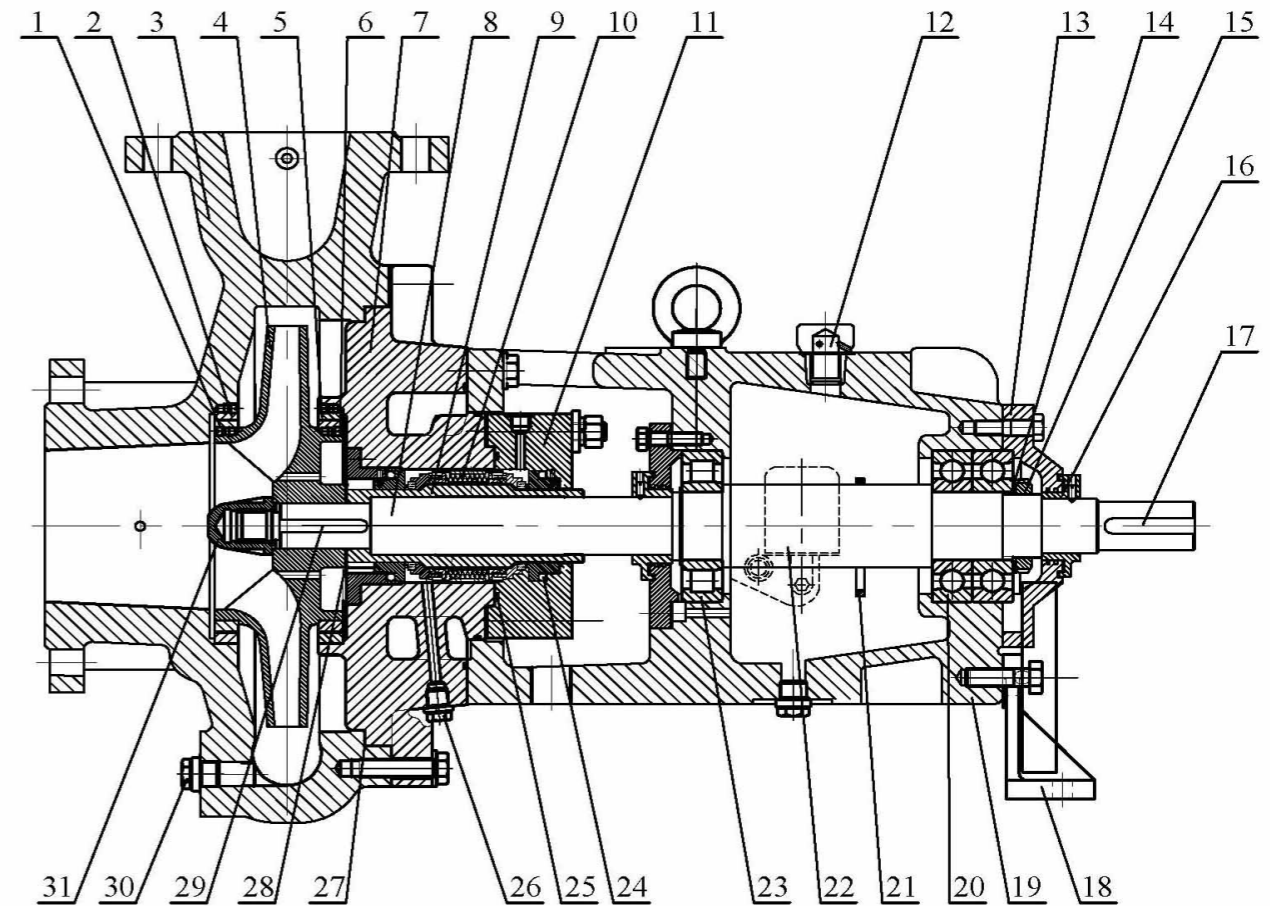

1. Impeller Wear Ring
2. Casing Wear Ring
3. Volute Casing
4. Impeller
5. Casing Wear Ring
6. Impeller Wear Ring
7. Casing Cover
8. Shaft
9. Shaft Sleeve
10. Mechanical Seal
11. Sealing Gland
12. Vent Filter
13. Bearing Gland
14. Collar
15. Bearing Nut
16. Deflector

17. Key
18. Supporting Foot
19. Bearing Bracket
20. Ball Bearing
21. Lubricating Ring
22. Constant-level Oiler
23. Antifriction Bearing
24. O-Ring
25. O-Ring
26. 1/4 Screwed Plug
27. Flat Gasket
28. Flat Gasket
29. Key
30. 1/2 Pipe Plug
31. Impeller Nut

# Design Features and Advantages

**6. Impeller designs**  
 Closed impeller ( standard )  
 Open impeller depending on size ( CA and CE ).  
 Inducer possible.  
 Optimum compliance with various operating conditions, closed impeller with high efficiencies, low NPSHr values.  
 Open impeller for very gaseous liquids, high solids concentrations, extremely low NPSHr values, small suction head required.

**5. Flush system according to API 682 plans.**

**4. Well dimensioned stuffing box chamber**  
 Possibility of replacing packing or mechanical seals of any design.

**7. Interchangeable wear parts**  
 Impeller and casing wear rings.  
 Shaft sleeve in the area of the shaft seal.  
 Flushing of casing wear ring possible.  
 When casing and impeller wear ring and shaft seal are subject to wear, casing, impeller and shaft can be reused.  
 Small wear of casing and impeller wear ring due to absence of solids.

**8. Double volute casing ( above 80mm branch size )**  
 Large branches.  
 Increased corrosion allowance.  
 Enclosed casing gasket.  
 Small radial thrust, small shaft deflection ( < 0.05mm ) in the area of the shaft seal.  
 Low branch velocity, low noise level due to additional primary measures at impeller, long rated lift of casings, casing joint cannot break.

**3. one-piece heavy duty bearing bracket**  
 Oil-lubricated antifriction bearing, with automatic lubrication and oil level control.  
 T ≤ 250°C, no cooling.  
 T > 250°C, air cooling ( fan or water cooling possible ).  
 With labyrinth sealing( standard ), radial sealing ring possible.  
 Stable, aligning shaft position, robust shaft with small shaft deflection.  
 Few bearing checks required no cooling water pipework.  
 No cooling water consumption.

**2. Interchangeable modular elements for various sizes**  
 Only 8 bearing frames for 46 sizes.  
 Same hydraulics ( impellers ) and bearing frames as for light or medium duty series.

**1. Process design API 610 ( Code OH1 & OH2 )**  
 Assembly unit coupling with spacer.  
 Design and maintenance standard complying with process industry is ensured.  
 Rapid disassembly or assembly.  
 Disassembly without removal of pipe work and diver.

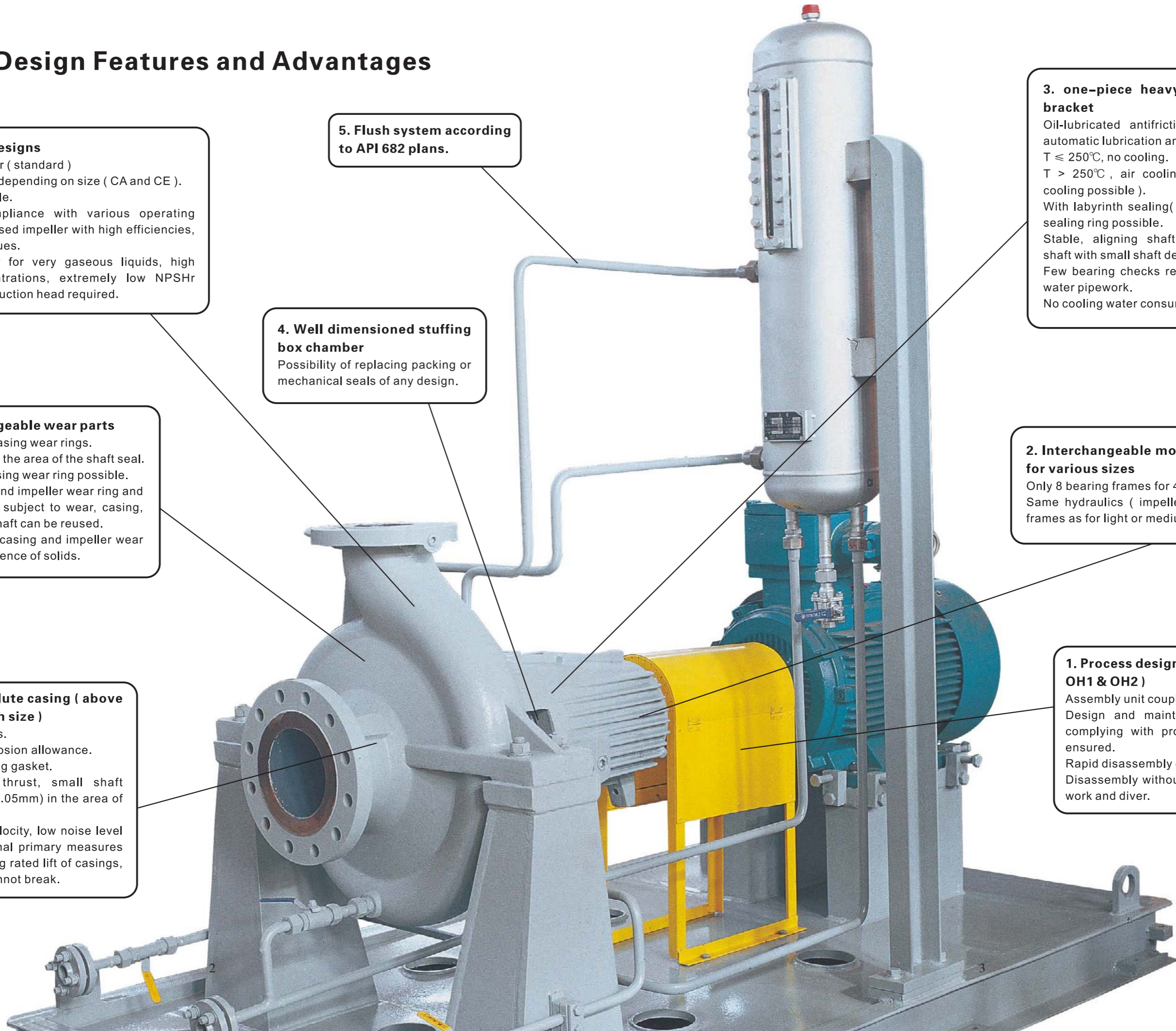

# Hydraulic Coverage

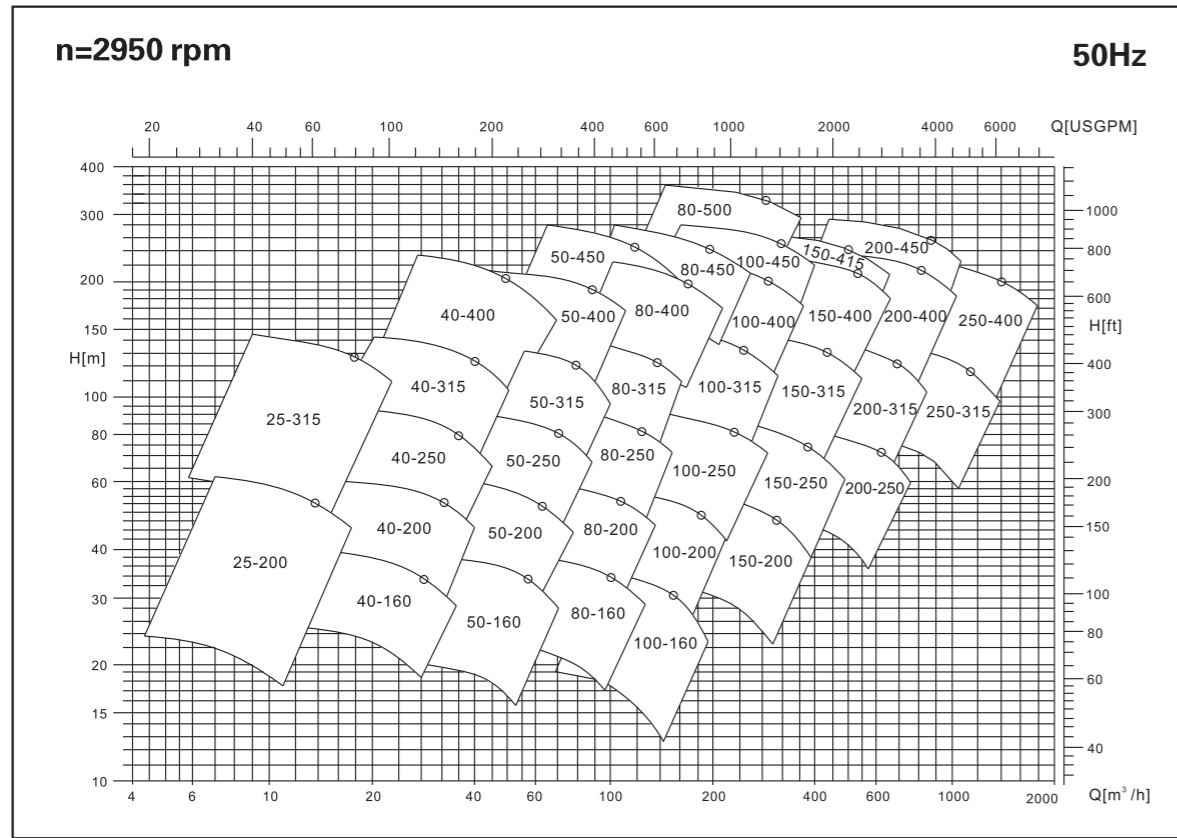

# Hydraulic Coverage

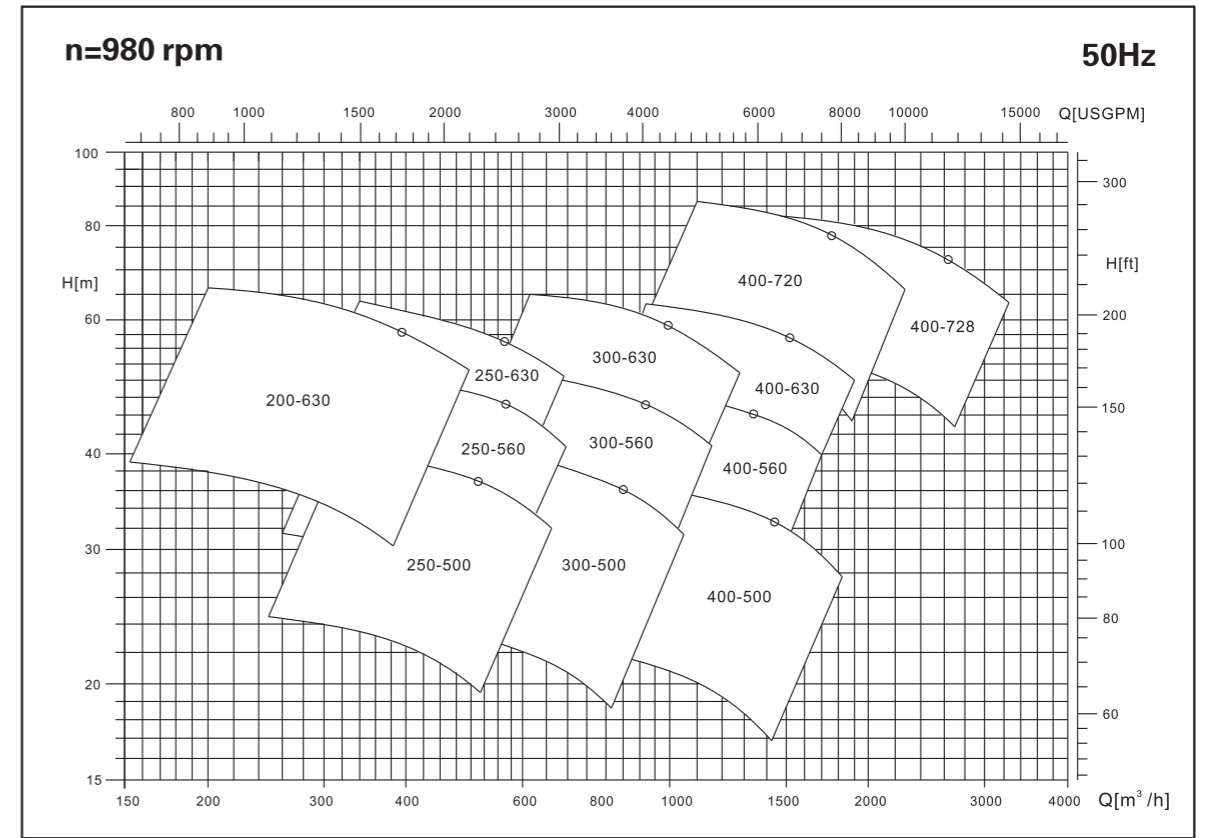

**n=1480 rpm**

**50Hz**

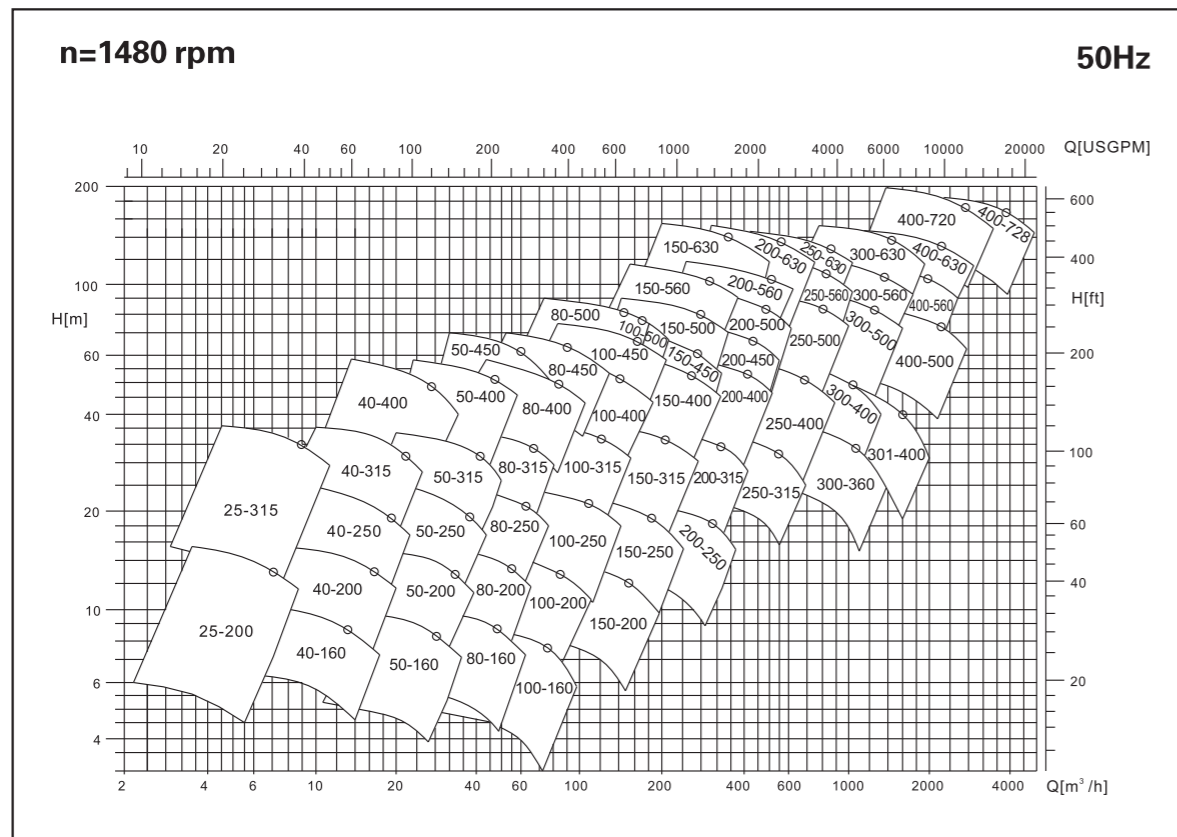

**n=3550 rpm**

**60Hz**

